

2005

VOLUME ONE
CALIFORNIA'S PREMIER
O-GAUGE AND O-SGA TRAINS

www.mtrains.com



© 2004 MTH. ALL RIGHTS RESERVED.

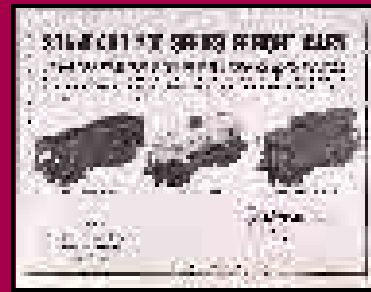
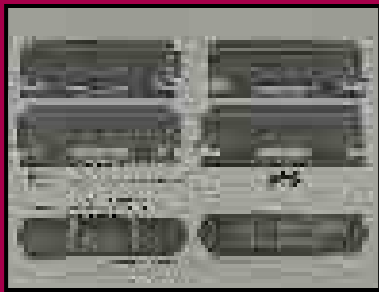

CELEBRATING 25 YEARS

Every successful business traces its roots to humble beginnings. Along with successes come periods of struggle, setbacks, and times of crisis that make achieving a milestone that much more satisfying. As we enter our 25th year in 2005, M.T.H. Electric Trains has indeed negotiated a number of obstacles on the path from a start-up one-room operation to an industry leader with a product line unmatched in variety, innovation, and value.



In 1980, Mike Wolf, then age 20 and already an eight-year veteran of the model train industry, opened a toy train mail order business in a bedroom of his family's Maryland home. Armed with a separate phone line and a fancy new device called a FAX machine, Mike managed the inventory, processed and shipped orders, worked train shows on weekends, and worked for another fledgling model railroad manufacturer - while carrying a full college course load during those first two years.

By the mid-1980s, Mike's Train House had also become a direct-to-consumer model train manufacturer with the release of its own line of standard gauge tinplate reproductions. The success of those first M.T.H. reproductions - financed by the loan of his parents' life savings - verified Mike's belief that opportunities awaited him in the model railroad industry.

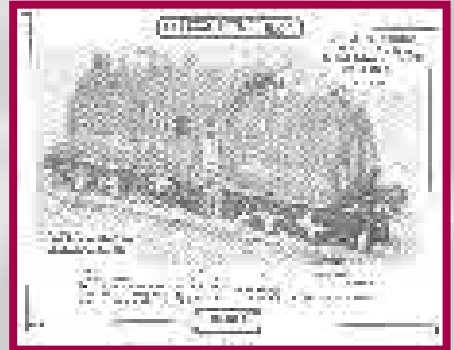

By the end of its first decade in business, Mike's Train House had become one of the leading O gauge distributors in the United States, with a modest workforce of nearly a dozen dedicated employees. More importantly, M.T.H. had firmly established its manufacturing expertise through subcontracting relationships with several leading model train manufacturers. Mike and his small band were the guiding force behind a number of locomotives that helped set new standards of realism and smooth, dependable operation for 3-rail O gauge model trains.

In 1992, however, significant changes in his subcontracting relationships forced Mike to rethink his company's direction. It was sink or swim time for Mike's Train House. Since sinking wasn't an option, the firm changed tracks

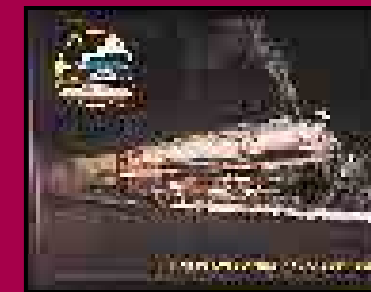
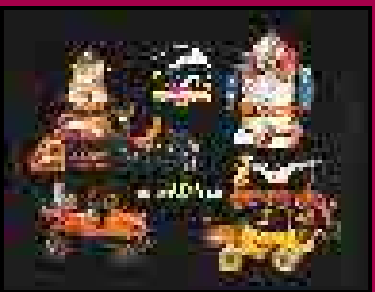



and began producing its own line of high-quality O scale products for the 2- and 3-rail markets. Now called M.T.H. Electric

Trains, the firm based its product line on a philosophy of manufacturing products based on consumer interest. Success came quickly because M.T.H. listened to what consumers wanted and then exceeded their expectations.

Creating smooth running, scale proportioned models of accessories, rolling stock, diesels, electrics, and steam engines that had never been offered to the O gauge market proved to be a winning formula for M.T.H. Locomotives never-before-seen in scale die-cast construction began appearing on hobby shop shelves and included, among others, the Union Pacific 4-6-6-4 Challenger and 4-8-8-4 Big Boy, DMIR 2-8-8-4 Yellowstone, Pennsy 4-4-6-4 Q2, Erie 2-8-8-2 Triplex, and Pennsylvania GG-1, DD-1 and L-5 electrics. Diesels and turbines of wide and varied prototypes were introduced, including the Union Pacific DD40AX, three different U.P. Turbines, Fairbanks Morse H10-44, Alco RS-27, Baldwin Centipede, and EMD SD24.



Rolling stock previously available only as expensive and fragile HO or O scale brass models, such as hot metal cars, Schnabel cars, Jordan spreaders and dozens of different caboose and freight car designs, was now available and affordable. All told, M.T.H. has invested over \$55 million in new tooling and molds over the past 13 years - an investment in the hobby that we believe is unmatched by any other model railroad manufacturer.

By the mid-1990s, traditional-sized RailKing offerings also began appearing in the M.T.H. lineup. Innovative track systems, powerful U.L.-approved steam locomotives made their way into RailKing ready-to-run train sets. Many were equipped with digital sound and had features no train set had ever possessed. Mike Wolf has long felt that train sets represent the best opportunity for model railroading to attract new hobbyists. "Skimping on train set value is akin," Mike is fond of saying, "to slamming the door on a customer. By making that first experience one of quality, value, and fun, I believe we open the door to creating a model railroader for life."



Certainly many a new customer has come to the wonderful world of model railroading during the past two and a half decades. Rising consumer interest helped spur M.T.H.'s belief that O gauge fans, so long limited to a few offerings with antiquated technology, were clamoring for variety and innovation. In fact, the pace of M.T.H.'s O Gauge product development was directly respon-

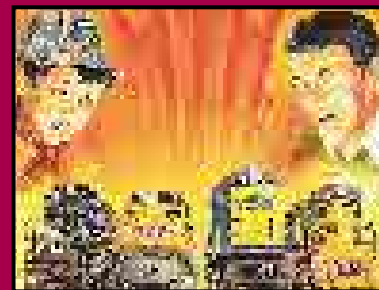
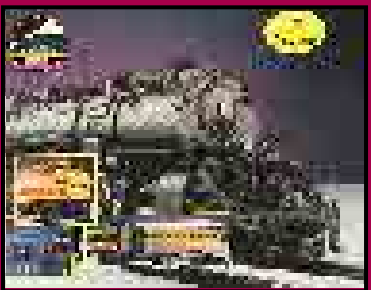
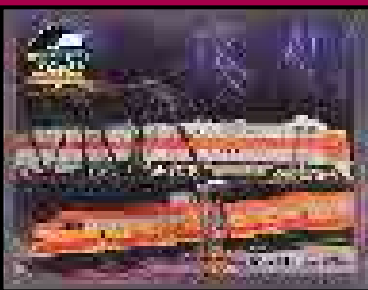

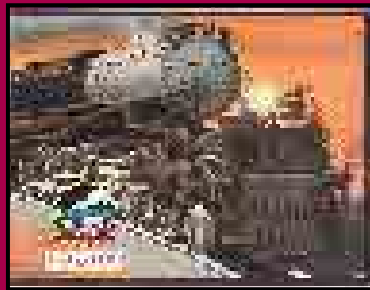
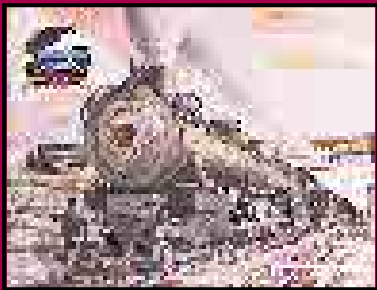

sible for the firm's remarkable growth during the 1990s and spurred the development of our RailKing One-Gauge product line and the reintroduction of tinplate reproductions. Offered with modern electronics, digital sound, and operating smoke, these new Tinplate Traditions items, including ready-to-

run train sets, helped ignite interest in the history of model railroading and toy train collecting for a whole new generation of enthusiasts. In addition, RailKing One-Gauge locomotives and rolling stock allowed 1/32 scale modeling of large mainline locomotives and rolling stock - a dimension long unfulfilled by our European counterparts. M.T.H. has also been a leader in

the use of the Internet, for informing our customers, providing access to parts and service, and - alone among model train manufacturers - allowing users to upgrade train control software and sound systems.

Amid M.T.H.'s variety - over 8,000 items introduced since 1992 - perhaps three products are the most visible of our successes. The first truly viable replacement for

the venerable ZW transformer appeared in the M.T.H. lineup in 1998, in the form of the Z-4000. This 400 watt, one-piece power supply retained the classic look of the ZW transformer while giving consumers the safety of a U.L.-approved design, power aplenty, and digital meters to monitor the action. The transformer long ago cemented itself as the best selling product in the company's 25-year history.

In 2000, the appearance of the first locomotives equipped with Proto-Sound 2.0 marked a second notable success. Unmatched digital sound variety, speed control that works on any layout without additional equipment, synchronized puffing smoke that no manufacturer has yet equaled, and command control options that make model railroading as much like real railroading as one can imagine now appear in virtually every M.T.H. locomotive, including those found in our ready-to-run train sets. This powerful yet easy-to-use sound and control system provides newcomers to the hobby with a clear example of how a century-old hobby can compete with modern, state-of-the-art pastimes - while shattering the myth that model railroading is boring and low-tech.

Finally, with the release of the DCS Digital Command System in 2002, M.T.H. offered a command control option that all of model railroading could appreciate. Simple to set up, easy to use, and fun to operate, DCS incorporates an

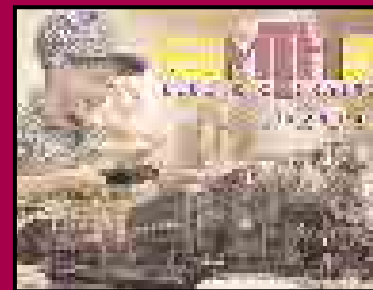
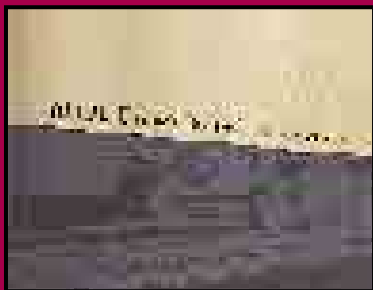



intuitive handheld controller that anyone can learn to use in minutes, two-way communication between locomotive and control system, and software that the user can program and upgrade over the Internet.

Proto-Sound 2.0 and DCS were designed to grow, much like M.T.H. has done over the past 25 years. The cost of developing these two items alone has been well over \$4 million. Yet thanks to such innovation, locomotives can be reprogrammed with new sounds and features, and a single DCS system can control M.T.H.'s Proto-Sound 2.0-equipped O Gauge, No. 1



Gauge, and beginning in 2005 HO gauge locomotives at the same time. We believe the future of model railroading would not be so bright if a new generation of consumers could not be cultivated. No other manufacturer's model railroading products combine the placement of power and performance in your hands, the addition of technology and innovation on your track, and the nostalgia and appeal of a century-old hobby in an easy-to-use, fun-filled package like a Proto-Sound 2.0 locomotive controlled by DCS.



Over the next 173 pages, you'll find more of the excitement we've been creating for the past 25 years. The excitement on these pages and the past successes of M.T.H. would not have been possible without strong support from you, our customers. Your comments, suggestions, and feedback have shaped and guided our company from the beginning, and for that we are truly grateful. We hope you will continue to share the hobby with your family and friends so that model railroading will remain headed down the main line for many years to come.

Thank you for 25 wonderful years.

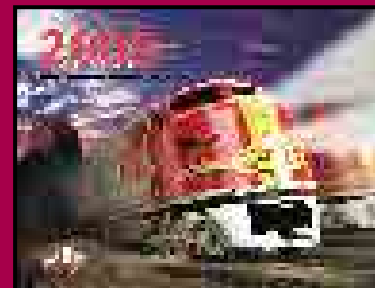
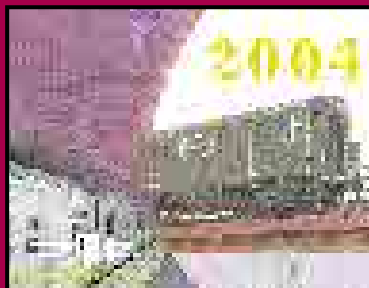
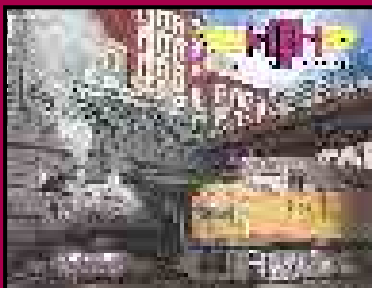

M.T.H. LOCOMOTIVES LEAD THE PACK

Compare an M.T.H. locomotive & you'll find a wealth of features unmatched by others. It all starts with the inclusion of digital sound in virtually every type of locomotive we produce.

Simple locomotive sound effects including engine, bell & horn effects come with every Loco-Sound equipped engine. For just a few dollars more, incredibly sophisticated but easy-to-use cd quality sounds are included in all Proto-Sound 2.0 locomotives as well as remote control operating couplers that can be activated at any time without additional equipment.

All Loco-Sound & Proto-Sound 2.0 equipped locomotives feature Locomotive Speed Control, the patented speed control system that allows a locomotive to maintain a desired speed regardless of terrain changes. Enter a curve, climb a grade or coast down an incline at the same speed without ever touching the throttle.

Each of these conventional features have been included in M.T.H. locomotives for the past three years & aren't found throughout any other manufacturer's entire locomotive roster. In fact, these features usually aren't found at all or simply fail to match the quality of M.T.H.

Demand Proto-Sound® 2.0 in your next locomotive

Proto-Sound 2.0 makes the most technologically advanced locomotives on the market.

Locomotives equipped with this sound & train control system offer tremendous expandability. They offer more features out of the box than any other engines, & when paired with the DCS Digital Command System they offer features other manufacturers cannot begin to compete with. Proto-Sound 2.0 is perfect for people who love technology & how it multiplies their fun.

Right out of the box, Proto-Sound® 2.0 engines deliver:

- Horn, Bell and Locomotive Digital Sound Effects
- Sound Effects, Including Passenger Station or Freight Yard Sounds & Cab Chatter
- Speed Control Equipped to Eliminate Throttle Adjustments
- Exclusive Synchronized Steam Engine Puffing Smoke
- Operating Couplers to Release Cars on the Fly
- Wide Range of State-of-the-Art Digital Sounds
- Adds Hundreds of Additional Features when operated with DCS

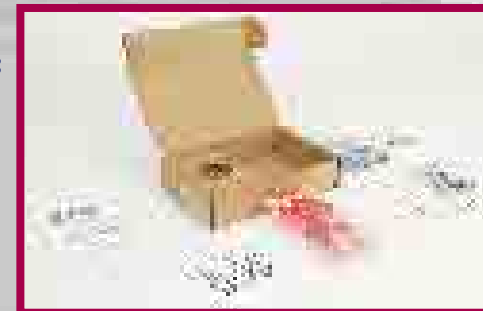

Upgrade other locomotives to Proto-Sound® 2.0

Proto-Sound 2.0 upgrade kit provides:

- **Patented Proto Speed Control** - run locomotives at constant speeds up & down grades, through curves with & without loads
- **Patented Proto-Coupler Operation** - uncouple your train at any time in conventional or command mode
- **Patented Synchronized Puffing Proto Smoke** - puffing smoke & chuffing steam sounds timed to driver revolutions
- **Patented Proto-Sounds 2.0 Digital Sound & Control Effects** - command control features & CD sound quality
- **Patented Software Upgradeable Design** - enhance locomotives with new features or sounds as they are created
- **Visit www.protosound2.com for details**

Performance Service Plan

All M.T.H. powered locomotives in the 2004 product line can now be purchased with an optional three-year M.T.H. Performance Service Plan (PSP) available either directly from M.T.H. or through your local M.T.H. Authorized Retailer. Each PSP ensures that you will receive added warranty protection beyond the normal M.T.H. one-year limited warranty. The PSPs are renewable and transferrable so the protection goes with your train, even if you sell it.

PSP Benefits:

- Parts & Labor On Proto-Sound 2.0 Electronics* is Fully Covered
- No Deductible Or Out-of-Pocket Expenses**
- Free Return Shipping
- Renewable
- Transferable

* Batteries, lights, pickup rollers are not included.

** Reimbursement of return shipping to factory is not included.

PSPs can be ordered online at www.mthtrains.com within 30 days of the date of purchase of a 2004 M.T.H. locomotive. PSPs can also be ordered from any M.T.H. Authorized Retailer, again within 30 days of purchase of a 2004 M.T.H. locomotive. Locomotives must be purchased from an M.T.H. Authorized Retailer and a copy of the sales receipt must be provided before the PSP will be issued.

Welcome Aboard!

Experience the exciting products M.T.H. has to offer this year!

M.T.H. Electric Trains proudly develops today's most popular and innovative locomotives, rolling stock, accessories and command control operating systems. Since 1992, only M.T.H. has consistently delivered what you desire in model railroad products by producing over 8,000 different items. You'll find them in O, Standard and Large Gauge sizes in enough variety to please the most discriminating enthusiast.

With each subsequent production, lessons learned from previous products are applied to new items ensuring that M.T.H. products continually evolve and improve. By intertwining technology into M.T.H. models, consumers can now own the most realistic operating locomotives available today in every level of the M.T.H. product line. Patented M.T.H. features like our locomotive speed control system, locomotive remote uncoupling system, synchronized puffing smoke and the excitement of Proto-Sound 2.0 and DCS are unmatched by others in the industry. Although advanced, every M.T.H. product is easy to use, easy to setup, and fun to operate. More importantly, all conventional features found in M.T.H. products can be accessed with a simple transformer equipped with only a bell and a whistle button.

Over the next 172 pages, you'll find all of M.T.H.'s 2005 O Gauge and O Scale product offerings. Operators and collectors alike can choose from a huge selection of affordable RailKing Proto-Sound 2.0 locomotives, rolling stock and passenger offerings or more detailed and sophisticated 1:48th O Scale Premier Line products. Only M.T.H. gives you the most choices and features guaranteed to ensure that your model railroad-ing experience will be the best it can be.

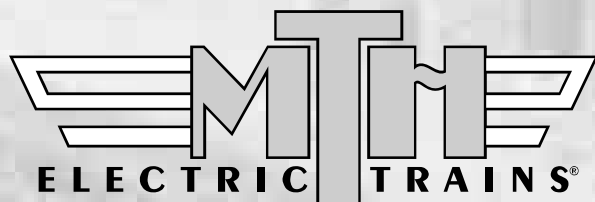

Table of Contents 2005 Volume 1



RailKing6



Premier60



Transformers136

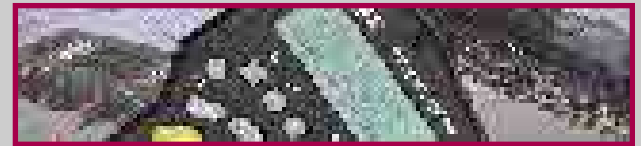

DCS138



Track Systems142

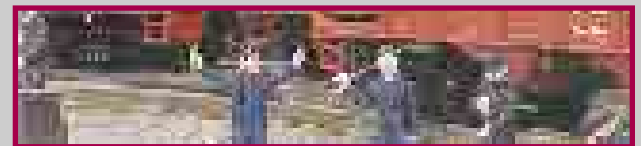

Accessories150

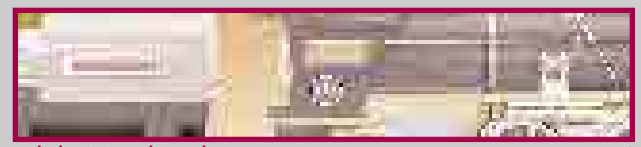

Club Membership174



Steam Locomotives 8

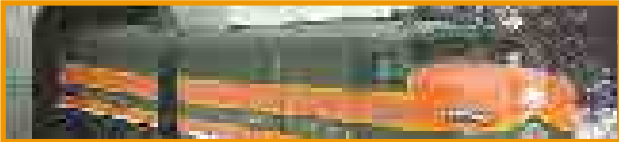

Diesel/Electric Locomotives 14

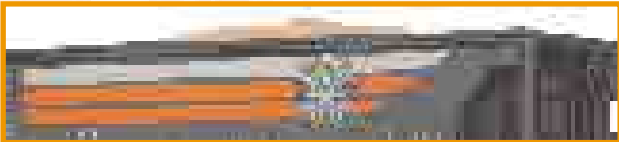

Freight 26



Subway Sets 50

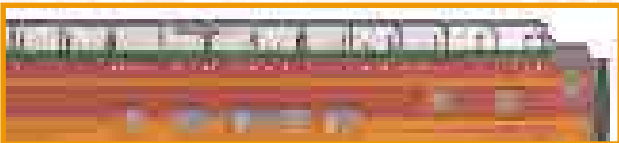

Passenger Sets 54





RailKing is M.T.H.'s most popular line of trains and accessories featuring a full line of high quality, traditionally sized models including locomotives, freight & passenger cars, track, accessories and electronics. Modelrailroaders who prefer to run their trains rather than collect and display them often find RailKing an attractive and affordable option.

Like our Premier offerings, RailKing locomotives are powerful and solidly built for years of operating enjoyment. Each locomotive features all metal wheels, gears & axles, flywheel equipped motors for smooth starts & stops, and state-of-the-art electronics for incredibly realistic operation. Many diesel locomotives are also available in non-powered versions for realistic double-heading.

RailKing Locomotives - Unmatched Features

- Patented Proto-Sound 2.0® Digital Sound and Train Control
- Patented Locomotive Speed Control
- Patented Remote Controlled Proto-Coupler Operation
- Patented Synchronized Puffing Smoke On Steam Locomotives
- Semi-Scale and Scale Proportions

RailKing Rolling Stock - Value In Every Box

- Die-Cast Sprung Metal Freight Trucks
- All-Metal Wheels and Axles
- Detailed Passenger Car Interiors
- Durable Detailed ABS Bodies
- Crisp, Attractive Paint Schemes

RailKing Accessories - Variety For Every Taste

- Fully Assembled and Decorated RailTown Buildings
- Semi-Scale and Scale Trackside Signals
- Realistic Operating Accessory Action

RealTrax - The Only Full-Line Simple Snap-Together Track System

- Solid, Nickel Silver Rails That Won't Rust or Crush
- Built-In Roadbed For Added Realism
- Sets Up In Minutes - Even On Carpet



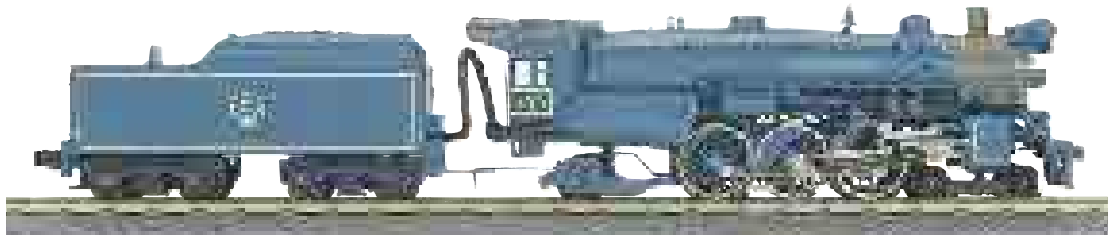

Jersey Central 4-6-2 P47 Pacific Steam Engine
30-1352-1 w/Proto-Sound® 2.0 \$349.95

**ADD
MATCHING
PASSENGER SETS!
SEE PAGE
54**

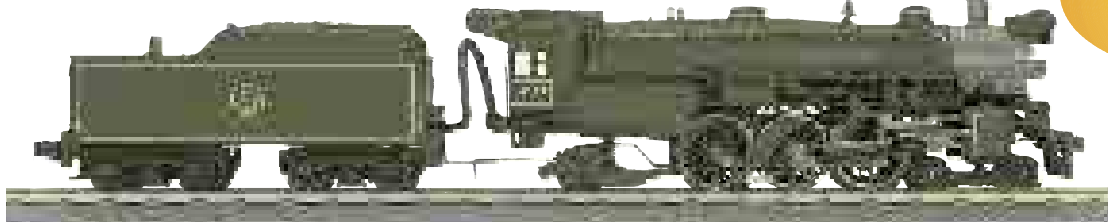

Jersey Central 4-6-2 P47 Pacific Steam Engine
30-1353-1 w/Proto-Sound® 2.0 \$349.95

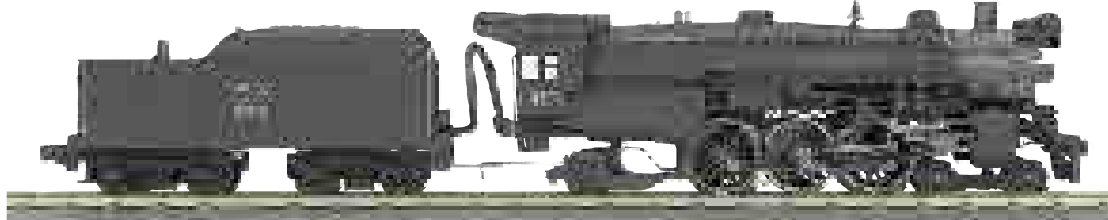

Jersey Central 4-6-2 P47 Pacific Steam Engine
30-1354-1 w/Proto-Sound® 2.0 \$349.95



Southern 4-6-2 Pacific Steam Engine
30-1355-1 w/Proto-Sound® 2.0 \$349.95

**ADD
MATCHING
PASSENGER SETS!
SEE PAGE
57**

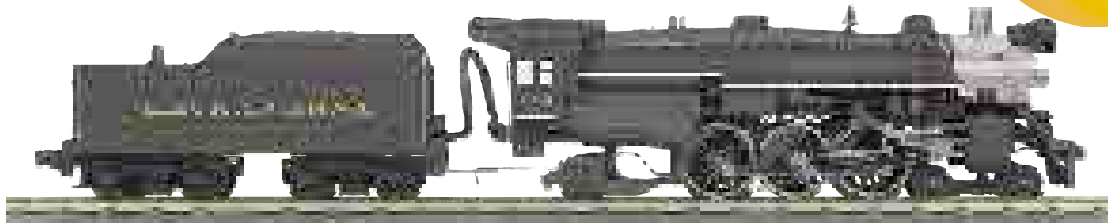

Lackawanna 4-6-2 Pacific Steam Engine
30-1356-1 w/Proto-Sound® 2.0 \$349.95

The Central of New Jersey, like many railroads of the day, required ever-changing motive power to cope with increasing traffic needs. As its aging fleet of 4-4-0s, 4-4-2s and 4-6-0s proved unable to handle greater passenger and freight loads, the CNJ turned to the standard of the day; the 4-6-2 Pacific type.

Five P47 Pacifics headed up the Jersey's famed passenger trains. Three locomotives - painted in a beautiful blue livery and numbered 831, 832 and 833 - were used for the Blue Comet. A fourth P47, No. 834 was painted green and pulled "The Bullet" while the last locomotive, No. 835, sported all black and hauled the Queen of the Valley.

Following on the heels of the 1999 M.T.H. RailKing Blue Comet, the green Bullet and Queen of the Valley debut in 2005. Sporting additional detail and the incredible power and performance of Proto-Sound 2.0, these locomotives may well be the smoothest running steam locomotives on your roster. Certainly its patented synchronized puffing smoke and Proto-Speed Control are unmatched by any other manufacturer and give the engine a level of performance you have to see to believe.

FEATURES

- Die-Cast Boiler and Tender Bodies
- Die-Cast Metal Chassis
- Metal Wheels and Axles
- Die-Cast Truck Sides
- Precision Flywheel Equipped Motor
- Remote Controlled Proto-Coupler™
- Colorful Paint Scheme
- Engineer and Fireman Figures
- Track Voltage Operating Headlight
- Metal Handrails and Decorative Bell
- Locomotive Speed Control
- Synchronized Puffing ProtoSmoke™ System
- Proto-Sound® 2.0 With The Digital Command System Featuring: Passenger Station Proto-Effects™
- Unit Measures: 20" x 2 1/2" x 3 1/2"
- Operates On O-31 Curves



Did You Know?

Steam switchers almost always had front and rear sand boxes, though the rear one was sometimes hidden inside the cab rather than appearing as a prominent dome.

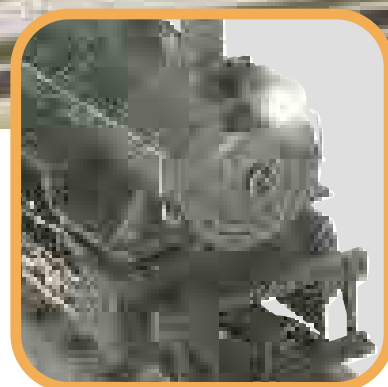

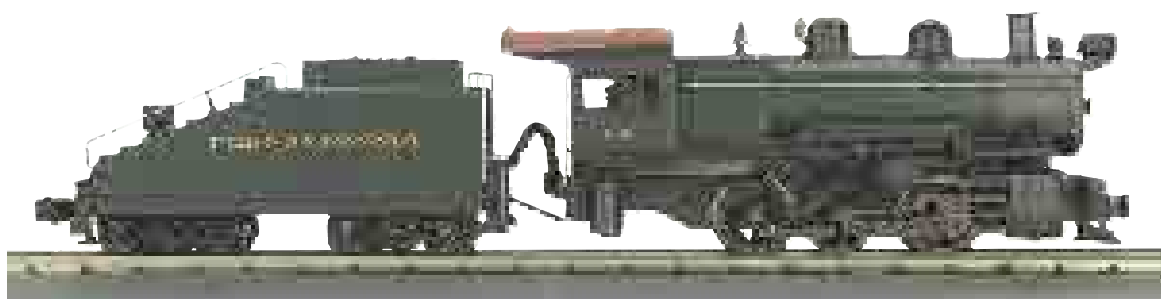

Pennsylvania 0-6-0 B-6 Switcher Steam Engine
30-1345-1 w/Proto-Sound® 2.0 \$349.95

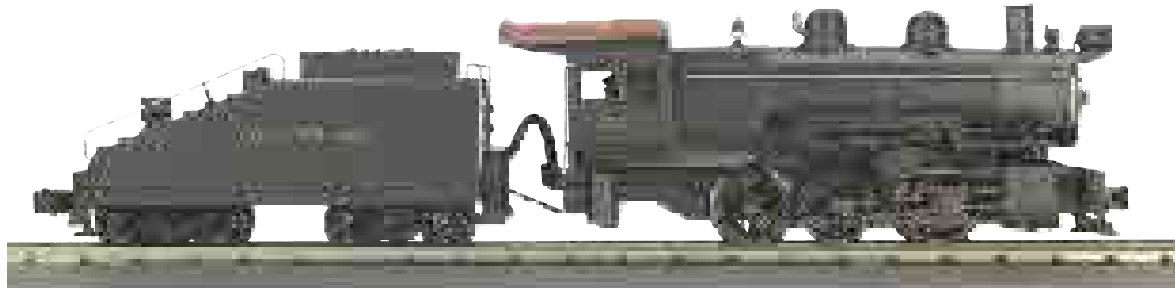

Long Island 0-6-0 B-6 Switcher Steam Engine
30-1344-1 w/Proto-Sound® 2.0 \$349.95

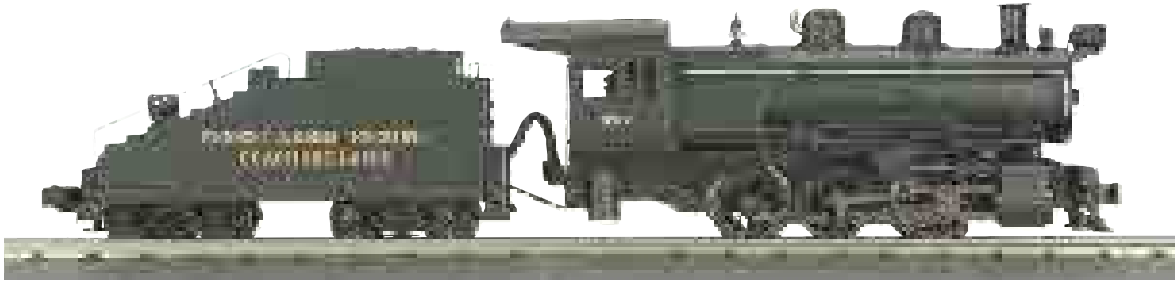

Pennsylvania-Reading Seashore 0-6-0 B-6 Switcher Steam Engine
30-1347-1 w/Proto-Sound® 2.0 \$349.95

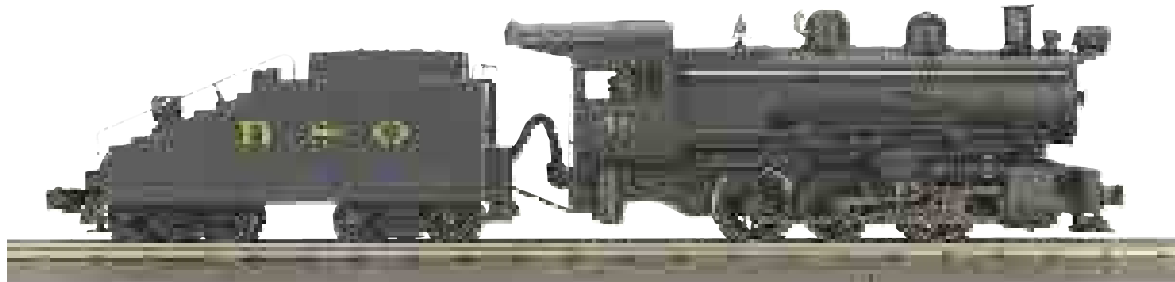

Baltimore & Ohio 0-6-0 B-6 Switcher Steam Engine
30-1346-1 w/Proto-Sound® 2.0 \$349.95

Switch engines are an essential, specialized piece of railroad equipment that look quite different from their kin that work the mainline. Because of the nature of their work, moving cars around railroad yards, switch engines spent much of their time waiting for their assignments. That means steam switchers needed smaller fireboxes, boilers, and tanks than road engines. The cut out or sloping tanks on most steam switchers were designed to give good rear visibility, which was essential for these small and agile engines that needed to slip into tight spaces where other engines could not fit. The 0-6-0 switcher would typically have been assigned to move about six cars at a time.

The rugged RailKing 0-6-0 is perfect for working the yard of any early twentieth-century layout. This sturdy model comes in the markings of the Pennsylvania, Long Island, Baltimore & Ohio, and Pennsylvania Reading & Seashore railroads.

- ### FEATURES
- Die-Cast Metal Chassis
 - Metal Wheels and Axles
 - (2) Remote Controlled Proto-Coupler™
 - Precision Flywheel Equipped Motor
 - Engineer and Fireman Figures
 - Metal Handrails and Decorative Bell
 - Decorative Metal Whistle
 - Die-Cast Boiler and Tender Body
 - Constant Voltage Headlight
 - Die-Cast Truck Sides
 - Locomotive Speed Control
 - Synchronized Puffing ProtoSmoke™ System
 - Operating Tender Back-up Light
 - Proto-Sound® 2.0 With The Digital Command System Featuring:- Freight Yard Proto-Effects™
 - Unit Measures: 17" x 2 1/2" x 3 5/8"
 - Operates On O-31 Curves



**ADD
MATCHING
PASSENGER SETS!
SEE PAGE
56**

FEATURES

- Die-Cast Boiler and Tender Body
- Metal Wheels and Axles
- Constant Voltage Headlight
- Die-Cast Truck Sides
- Precision Flywheel Equipped Motor
- Remote Controlled Proto-Coupler™
- Metal Handrails and Decorative Bell
- Engineer and Fireman Figures
- Decorative Metal Whistle
- Operating Marker Lights
- Operating ProtoSmoke™ System
- Operating Tender Back-up Light
- Locomotive Speed Control
- Proto-Sound® 2.0 With The Digital Command System Featuring: Passenger Station Proto-Effects
- Operates On O-31 Curves
- Unit Measures: 22 5/16" x 2 1/2" x 3 3/4"

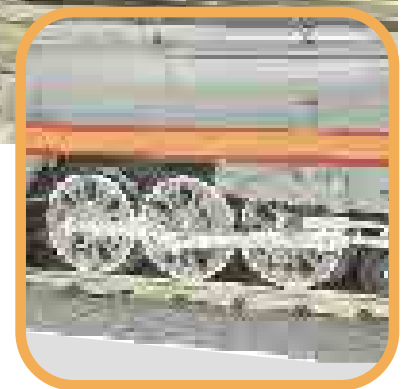
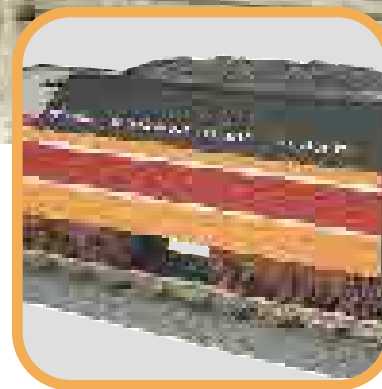



Milwaukee Road 4-6-4 Hiawatha Hudson Steamer
30-1348-1 w/Proto-Sound® 2.0 \$349.95

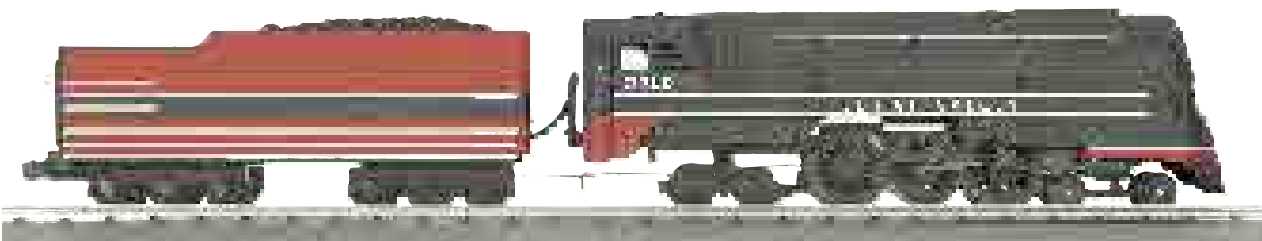

Lehigh Valley 4-6-4 Streamlined Hudson Steamer
30-1350-1 w/Proto-Sound® 2.0 \$349.95

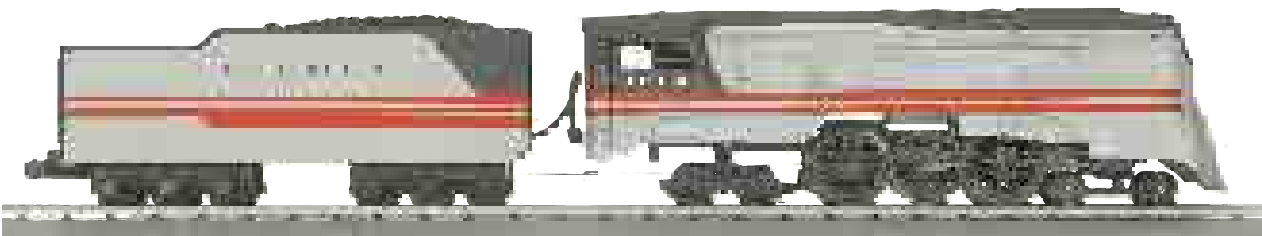

Burlington 4-6-4 Streamlined Hudson Steamer
30-1349-1 w/Proto-Sound® 2.0 \$349.95

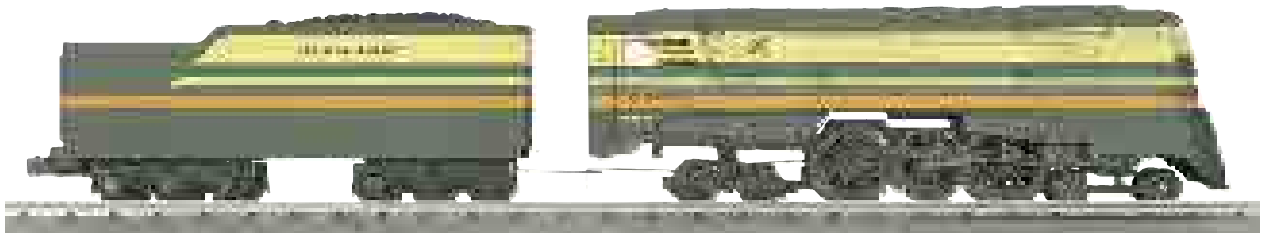

Seaboard 4-6-4 Streamlined Hudson Steamer
30-1351-1 w/Proto-Sound® 2.0 \$349.95

Did You Know?

The F7 was capable of running up to 125 miles per hour prompting a proposal to increase the cruising speed of the Hiawatha from 90 to 105 miles per hour along the Chicago-to-Milwaukee route. However, a gentleman's agreement between the three railroads competing along the route prohibited the increase as the other two roads did not have the ability to reach such speeds.

With the bold slogan "Nothing Faster on Rails," the Milwaukee Road inaugurated its Chicago-Twin Cities Hiawatha passenger service on May 29, 1935. Pressured by intense competition on the route between Chicago and Minneapolis/St. Paul - including the Burlington's pioneering diesel Twin Zephyrs - the Milwaukee Road had turned to the American Locomotive Works to design the fastest steam locomotives of the day. The results did not disappoint.

The Hiawathas were initially headed by oil burning Alco 4-4-2 Atlantics created specifically for intense 100 mile per hour daily operations. The engines and their entire trains were renowned for their colorful, aerodynamic styling by industrial designer Otto Kuhler - who lamented, however, that "I did get disgusted every time an uninitiated person asked me, 'Is that a diesel?'" The Hiawathas seduced passengers with luxurious surroundings that included the Tip Top Tap Room, the first standup cocktail bar on American rails.

The popularity of the service soon mandated longer trains and larger locomotives. Enter the Kuhler-styled coal-burning F7 4-6-4 Hudsons turned out by Alco in 1938. Among the heaviest Hudsons ever built, the massive F7s outclassed the more-famous New York Central J-series Hudsons in almost every way: larger firebox, higher boiler pressure, taller drivers (84"), and more power at speed. Unlike the NYC Hudsons, however, the F7s were born just as their technology was dying. Within a decade, the F7s and their trains were replaced by diesel-powered Hiawathas magnificently styled by designer Brooks Stevens. Sadly, none of the steam-powered Hiawathas were preserved.

Fortunately, your O gauge railroad can recreate the sights and sounds of this legendary train. Last seen in the RailKing line in 1998, the Hiawatha Hudson features die-cast locomotive and tender construction and the latest M.T.H. features, including synchronized puffing Proto-Smoke and the incredible sounds and performance of Proto-Sound® 2.0.



Did you know?

Introduced in 1902, the "semi-convertible" was used in all parts of the country. Both upper and lower window sash raised up into the roof to give better air flow in summer, making removable side panels unnecessary.

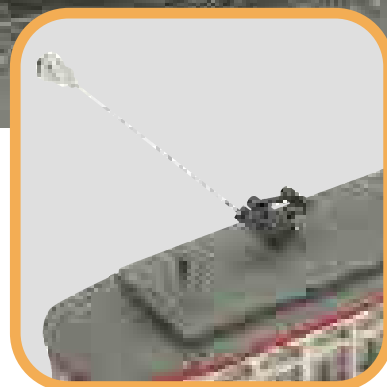

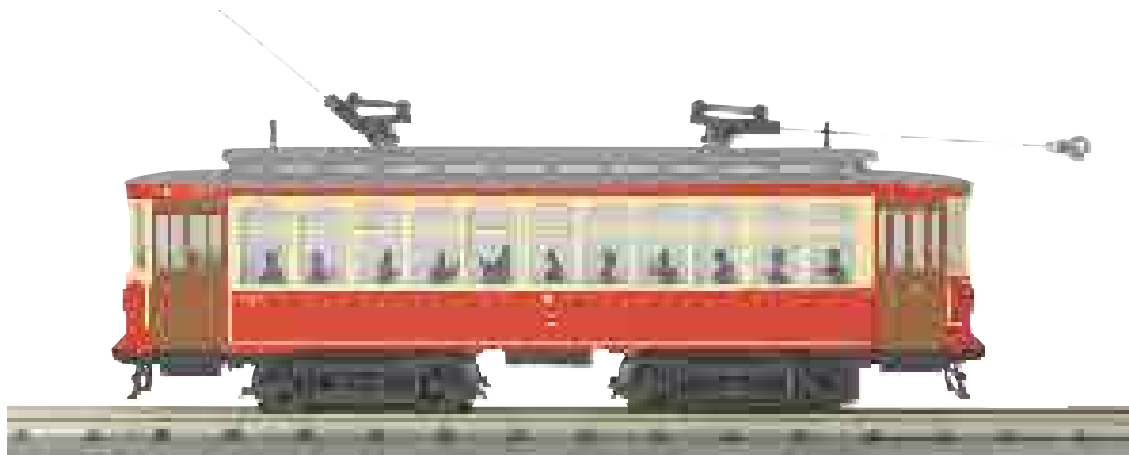

Chicago Brill Semi-Convertible Trolley
30-2567-1 w/Proto-Sound® 2.0 \$229.95

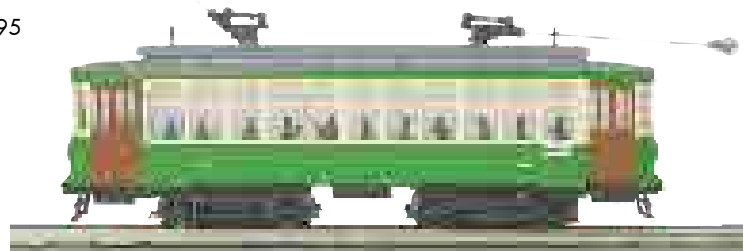

Philadelphia Brill Semi-Convertible Trolley
30-2568-1 w/Proto-Sound® 2.0 \$229.95

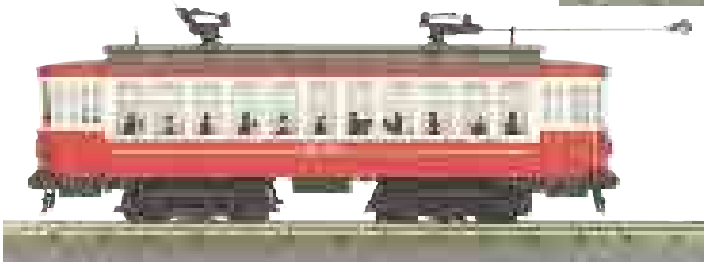

Baltimore City Brill Semi-Convertible Trolley
30-2566-1 w/Proto-Sound® 2.0 \$229.95



WW II (Buy War Bonds) Trolley Brill Semi-Convertible Trolley
30-2569-1 w/Proto-Sound® 2.0 \$229.95

Founded by a German immigrant, skilled in cabinetmaking, the J.G. Brill Company was founded in 1869 in Philadelphia, Pennsylvania by John George Brill and his son, George Martin Brill. Initially producing all kinds of cars including horse-drawn streetcars, cable cars, and passenger cars for steam railroads, the firm's fortunes soon changed through its concentration on the booming streetcar market during the mid 1880s.

Through acquisitions of smaller manufacturers such as American Car Company, St. Louis, MO (1902), G.C. Kuhlman Car Company, Cleveland, OH (1904), John Stephenson Company, Elizabeth, NJ (1904) and the Wason Manufacturing Company, Springfield, MA (1906), the Brill Company gained access to strategically located plants in most parts of the country.

One of the more notable Brill designs were the patented Brill Convertible Car, in which removable side panels made the same car either opened or closed; the patented semi-convertible, introduced in 1902, with roof pockets where both sashes lodged, one upon the other; the "Narragansett" car, an open car with a patented two-step running board to facilitate boarding by women in tight skirts; the heavy steel high-speed articulated cars built in 1926 for the Washington, Baltimore & Annapolis; and the lightweight, high-speed Bullet cars (below) developed in 1930.

The RailKing Semi-Convertible Trolley, like all M.T.H. transit cars, is equipped with power and performance of Proto-Sound® 2.0 whose unique features make creating an automatic trolley run simple and fun.

FEATURES

- Directionally Controlled Headlights
- Intricately Detailed ABS Body
- Metal Wheels, Axles and Gears
- Operating Pantograph Pole
- Die-Cast Truck Sides & Pilots
- Colorful Paint Scheme
- Precision Flywheel Equipped Motor
- Locomotive Speed Control
- Lighted Cab Interior
- Illuminated Number Boards
- Proto-Sound® 2.0 With The Digital Command System Featuring: Station Stop Proto-Effects
- Operates On O-31 Curves
- Unit Measures: 10 5/16" x 2 1/8" x 3 13/16"

RAILKING
scale



Did you know?

In a December 1950 radio show, famed comedian Jack Benny wrote a letter to Dear Santa Fe, saying "Christmas is almost here and it would make me happy if you gave me a train." While the railroad did not give Benny the real train he asked for, its publicity department did send him a toy train model of the F3.



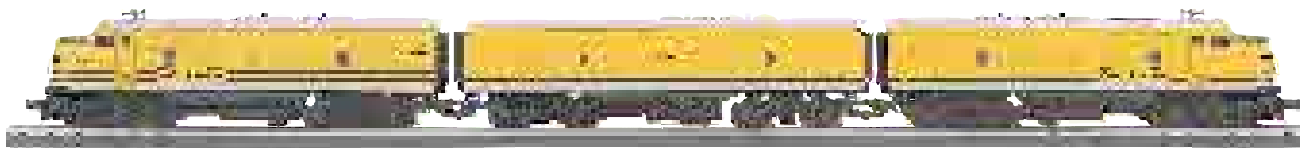

POST-WAR LIVERY Denver Rio Grande F-3 ABA Diesel Engine Set
30-2468-1 w/Proto-Sound® 2.0 \$499.95



POST-WAR LIVERY Santa Fe F-3 ABA Diesel Engine Set
30-2471-1 w/Proto-Sound® 2.0 \$499.95



POST-WAR LIVERY New Haven F-3 ABA Diesel Engine Set
30-2469-1 w/Proto-Sound® 2.0 \$499.95



POST-WAR LIVERY Southern F-3 ABA Diesel Engine Set
30-2470-1 w/Proto-Sound® 2.0 \$499.95

ADD MATCHING PASSENGER SETS! SEE PAGE 56



When the prototype railroads began to dieselize in the 1940s, model train manufacturers soon followed recognizing that boys wanted models of the newest trains they were seeing on real railroads. One of the initial toy train forays into dieselism was a replica of the best-selling diesel of the day, the F3 "covered wagon" made by the Electro Motive Division of General Motors.

Recognizing that EMD and the railroads were anxious to publicize their modern motive power, General Motors, the Santa Fe Railroad, and the New York Central Railroad helped share the cost of dies for the original models in exchange for having their names on engines that appeared on virtually every boy's holiday wish list for years. In the end, it seems the Santa Fe got the best deal, as its red, yellow, and silver "warbonnet" F3s remained a popular fixture on model railroad locomotives longer than any other railroad livery.

To this day, the F3 diesels of the late 1940s and early 1950s are recognized as some of the best toys ever produced. Virtually full O gauge scale models, they were tremendously dependable, highly detailed for their time, and terrific pullers.

Postwar and RailKing Scale fans will no doubt want to order this stellar M.T.H. replica of model railroading's most famous diesel. The look and feel of the classic original is faithfully reproduced, right down to the die-cast metal chassis. Under the hood, however, lies the power and performance of ProtoSound® 2.0, twin flywheel-equipped motors, and Proto-Smoke, offering today's model railroaders an operating experience that boys of the 1950s could only dream about.

- FEATURES**
- Colorful Paint Scheme
 - Die-Cast Metal Chassis
 - Die-Cast Truck Sides, Pilots and Fuel Tank
 - Metal Wheels, Axles and Gears
 - (2) Precision Flywheel Equipped Motors
 - (2) Remotely Controlled Proto-Couplers™
 - Directionally Controlled Headlight
 - Intricately Detailed ABS Bodies
 - Locomotive Speed Control
 - Operating Smoke Unit
 - Engineer Cab Figure In Each A Unit
 - Proto-Sound® 2.0 With The Digital Command System Featuring: Passenger Station Proto-Effects
 - AA Set Measures: 40 1/4" x 2 5/8" x 3 3/4"
 - Operates On O-31 Curves

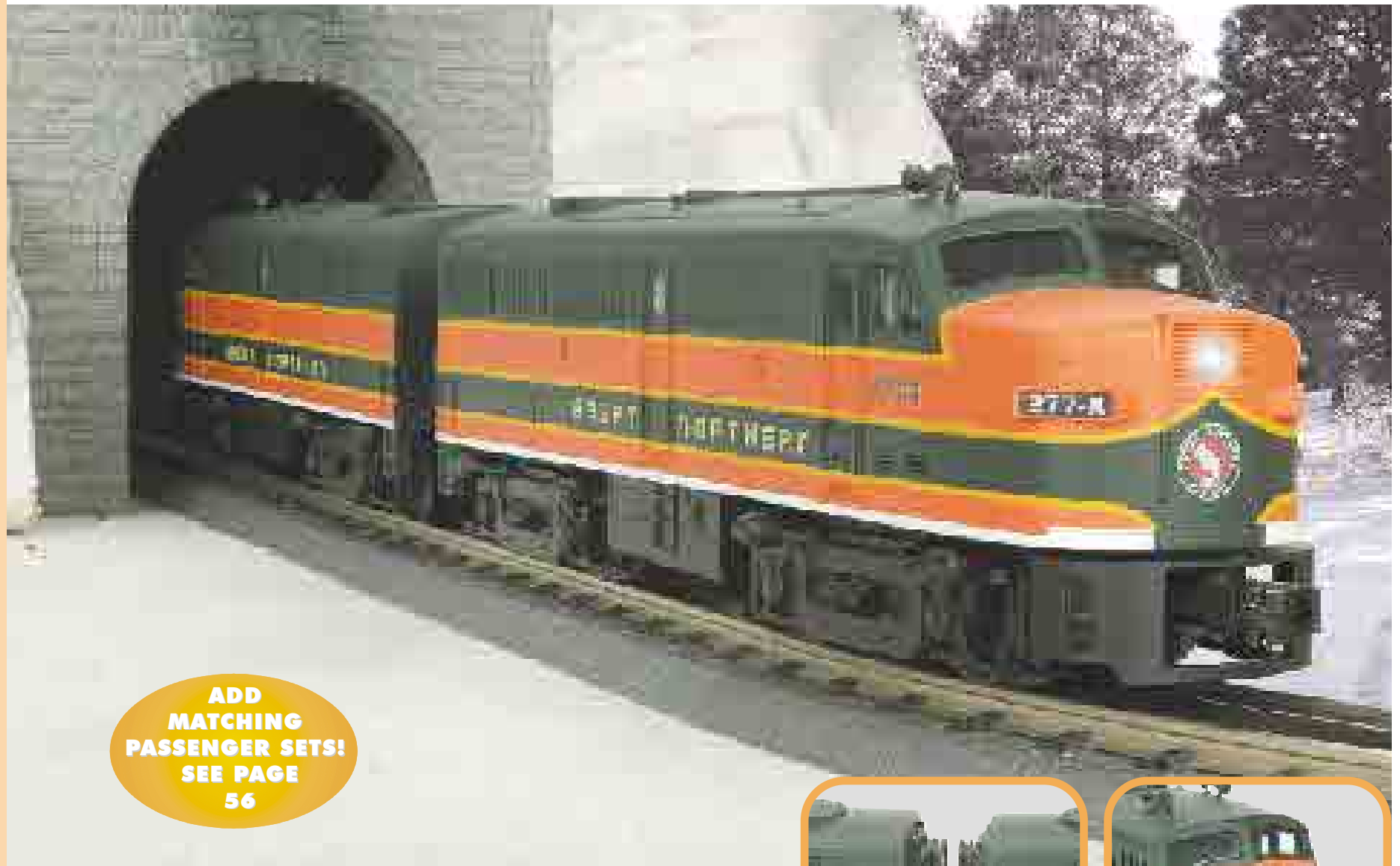

**ADD
MATCHING
PASSENGER SETS!
SEE PAGE
56**

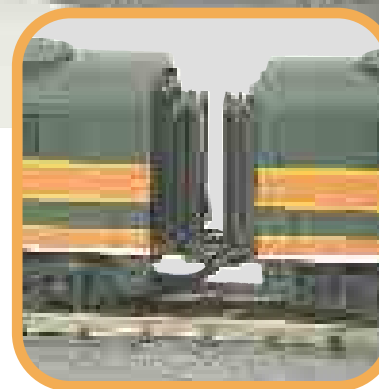
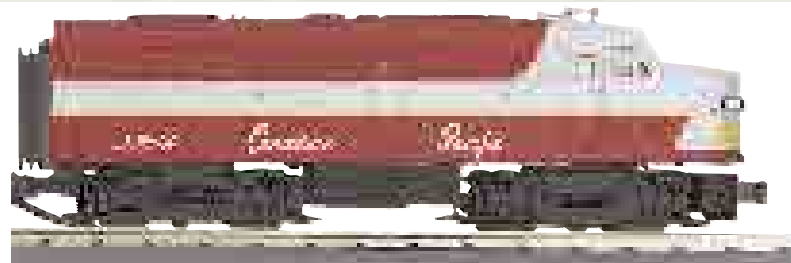

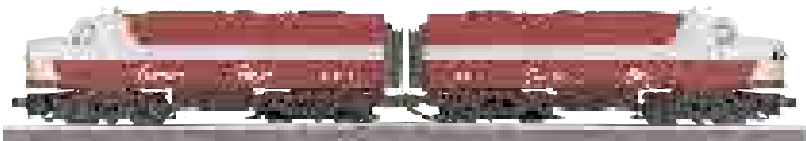

Canadian Pacific FA-2 AA Diesel Set
30-2472-1 w/Proto-Sound® 2.0 \$299.95

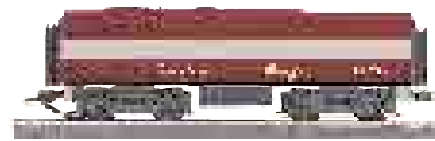

Canadian Pacific FA-2 B Unit (Non-Powered)
30-2472-3 \$69.95



Southern Pacific FA-2 AA Diesel Set
30-2476-1 w/Proto-Sound® 2.0 \$299.95



Southern Pacific FA-2 B Unit (Non-Powered)
30-2476-3 \$69.95



Western Maryland FA-2 AA Diesel Set
30-2475-1 w/Proto-Sound® 2.0 \$299.95



Western Maryland FA-2 B Unit (Non-Powered)
30-2475-3 \$69.95



Pennsylvania FA-2 AA Diesel Set
30-2474-1 w/Proto-Sound® 2.0 \$299.95



Pennsylvania FA-2 B Unit (Non-Powered)
30-2474-3 \$69.95



Great Northern FA-2 AA Diesel Set
30-2473-1 w/Proto-Sound® 2.0 \$299.95



Great Northern FA-2 B Unit (Non-Powered)
30-2473-3 \$69.95

Did you know?

The FA was Alco's response to the overwhelming success of General Motors' F-3 diesel. Though similar in appearance, the F-3 was still the best selling diesel of all time with over 1800 manufactured between 1945 and 1949.

The American Locomotive Company, one of the nation's premier steam locomotive builders, joined forces with Schenectady, New York neighbor General Electric to build the first standardized diesel-electric locomotives in the 1920s. But when the diesel revolution began in earnest after World War II, dependability problems with Alco's model 244 prime mover doomed the company to forever playing second fiddle to industry leader EMD.

The brawny good looks of Alco's FA and PA cab units, however, have endeared them to railfans and modelers for more than half a century. Many would argue that Alco's FA-1 and successor FA-2 diesels were both handsomer and more powerful looking than their major competitors, EMD's F3 and F7 "covered wagons." A signature feature of Alco cab units was the striking ribbed grille surrounding the headlight.

While Alco FA's were sold primarily as freight haulers, they did have room for a passenger-service steam generator at the rear of the engine compartment. Compared with the FA-1, the FA-2 was slightly longer to accommodate a larger steam generator and just a bit more powerful, developing 1600 hp. Alco built FA-2s and cabless FB-2 boosters from 1950 through 1956.

The M.T.H. RailKing FA-2 AA diesel set includes one twin-motored A unit and one non-powered unit; both have full lighting and a Proto-Coupler on the cab end. Like all RailKing diesel locomotives, the set is equipped with the legendary power and performance of Proto-Sound® 2.0. In addition, a separate non-powered B-unit can be ordered to create an ABA lashup.

FEATURES

- Colorful Paint Scheme
- Metal Chassis
- Die-Cast Truck Sides, Pilots and Fuel Tank
- Metal Wheels, Axles and Gears
- (2) Precision Flywheel Equipped Motors
- Directionally Controlled Headlights
- (2) Remotely Controlled Proto-Couplers™
- Intricately Detailed ABS Bodies
- Locomotive Speed Control
- Proto-Sound® 2.0 With The Digital Command System Featuring: Passenger Station Proto-Effects
- AA Set Measures: 25" x 2 1/2" x 3 1/2"
- Operates On O-31 Curves

RAILKING
scale



**ADD A NON-POWERED UNIT FOR
REALISTIC MULTI-UNIT LASH-UP**

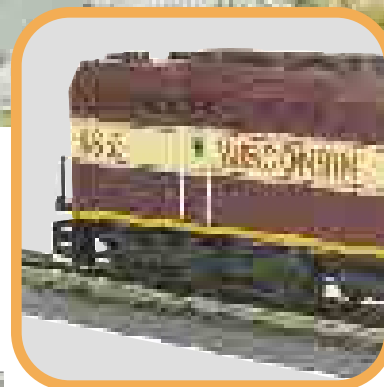

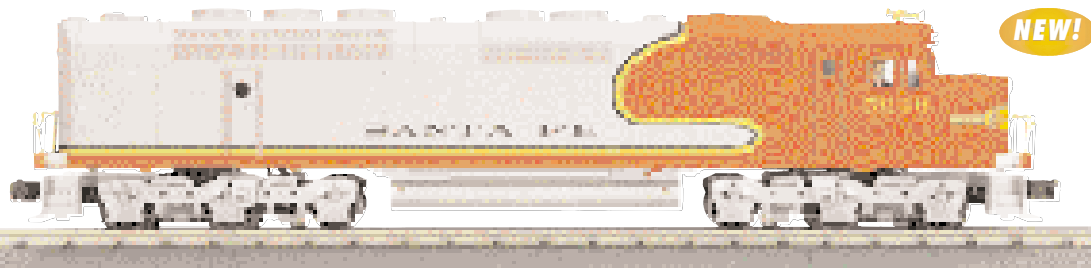

Santa Fe FP-45 Diesel Engine
 30-2460-1 w/Proto-Sound® 2.0 \$299.95
 Santa Fe FP-45 Diesel Engine
 30-2460-3 (Non-Powered) \$129.95

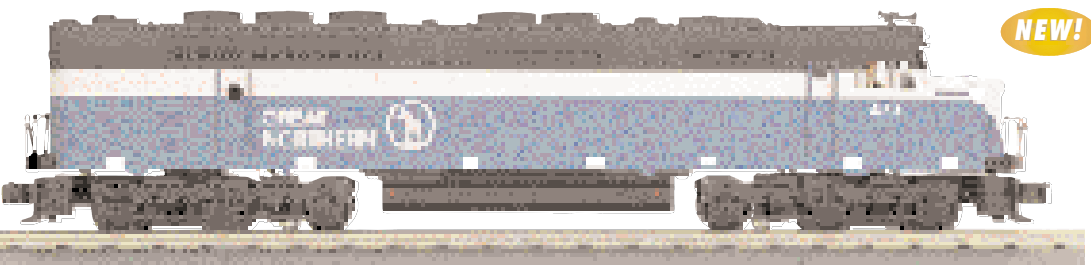

Great Northern FP-45 Diesel Engine
 30-2459-1 w/Proto-Sound® 2.0 \$299.95
 Great Northern FP-45 Diesel Engine
 30-2459-3 (Non-Powered) \$129.95

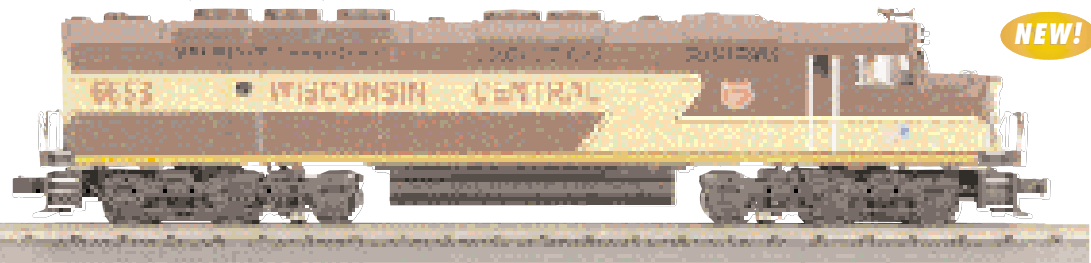

Wisconsin Central FP-45 Diesel Engine
 30-2458-1 w/Proto-Sound® 2.0 \$299.95
 Wisconsin Central FP-45 Diesel Engine
 30-2458-3 (Non-Powered) \$129.95

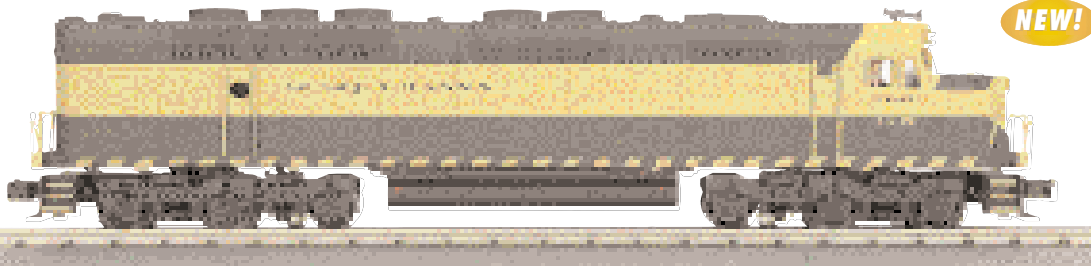

Susquehanna FP-45 Diesel Engine
 30-2457-1 w/Proto-Sound® 2.0 \$299.95
 Susquehanna FP-45 Diesel Engine
 30-2457-3 (Non-Powered) \$129.95

Designed in 1967 at the request of the Santa Fe, the FP45 was basically an SDP45 road switcher with a streamlined cab unit body. The "P" in FP45 indicated a passenger diesel with a steam generator for train heat. Having a sleeker, more aerodynamic look than a road switcher, the FP45 blended better with its passenger consists; the fully enclosed body also reduced wind resistance and allowed the crew to perform troubleshooting and minor maintenance on the road.

Purchased for passenger service by the Santa Fe and the Milwaukee Road, the 3600 hp FP45s replaced first-generation E-unit and F-unit diesel sets and eventually found themselves handling freight duties as well. By 1971, the units remaining in passenger service were working exclusively for Amtrak. A sister engine, the F45, was bought for freight-only service by the Santa Fe, Great Northern, and Burlington Northern.

Having first appeared in the M.T.H. Premier Line in 1997, the FP45 makes its long-awaited return in 2005 as part of the RailKing Scale diesel lineup. Built to 1/48 scale proportions and outfitted with Proto-Sound® 2.0, the FP45 includes all the features that make RailKing Scale locomotives one of the best values in model railroading.

NON-POWERED FEATURES

- Intricately Detailed ABS Body
- Die-Cast Truck Sides, Pilots and Fuel Tank
- Metal Handrails and Decorative Horn
- Engineer Cab Figure
- Metal Wheels and Axles
- (2) Operating Metal Couplers
- Operates On O-31 Curves
- Measurements: 18 1/2" x 2 9/16" x 4"

ADDITIONAL POWERED FEATURES

- Directionally Controlled Headlight
- (2) Remotely Controlled Proto-Couplers™
- (2) Precision Flywheel Equipped Motors
- Locomotive Speed Control
- Lighted Cab Interior
- Engineer Cab Figure
- Operating Smoke Unit
- Proto-Sound® 2.0 With The Digital Command System Featuring: Freight Yard Proto-Effects



NON-POWERED FEATURES

- Die-Cast Truck Sides, Pilots and Fuel Tank
- Colorful Paint Scheme
- Metal Chassis
- Metal Handrails and Decorative Horn
- Intricately Detailed ABS Body
- Metal Wheels and Axles
- Engineer Cab Figure
- Unit Measures: 16" x 2 3/4" x 4"
- Operates On O-31 Curves

ADDITIONAL POWERED FEATURES

- Directionally Controlled Headlights
- (2) Remotely Controlled Proto-Couplers™
- Metal Chassis
- Metal Handrails and Decorative Horn
- (2) Precision Flywheel Equipped Motors
- Operating Smoke Unit
- Locomotive Speed Control
- Proto-Sound® 2.0 With The Digital Command System Featuring: Freight Yard Proto-Effects



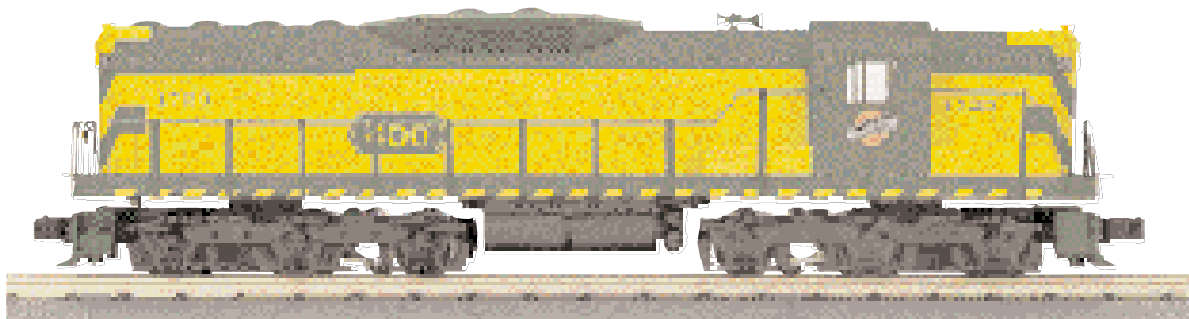

Chicago NorthWestern SD9 Diesel Engine		
30-2461-1	w/Proto-Sound® 2.0	\$299.95
Chicago NorthWestern SD9 Diesel Engine		
30-2461-3	(Non-Powered)	\$129.95

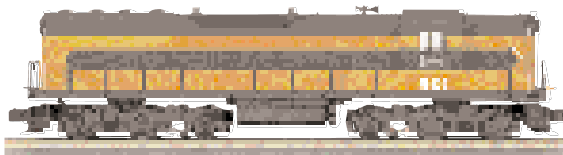

Bessemer & Lake Erie SD9 Diesel Engine		
30-2478-1	w/Proto-Sound® 2.0	\$299.95
Bessemer & Lake Erie SD9 Diesel Engine		
30-2478-3	(Non-Powered)	\$129.95

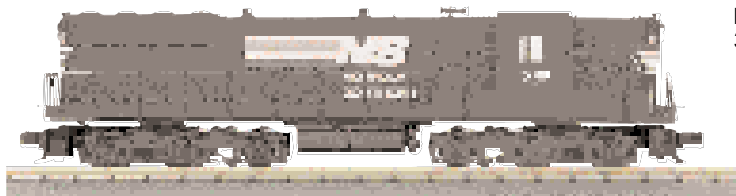

Norfolk Southern SD9 Diesel Engine		
30-2463-1	w/Proto-Sound® 2.0	\$299.95
Norfolk Southern SD9 Diesel Engine		
30-2463-3	(Non-Powered)	\$129.95

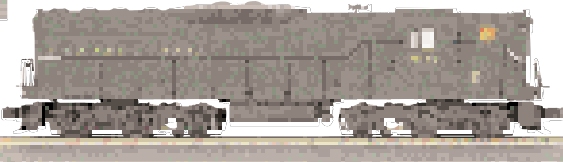

Pennsylvania SD9 Diesel Engine		
30-2464-1	w/Proto-Sound® 2.0	\$299.95
Pennsylvania SD9 Diesel Engine		
30-2464-3	(Non-Powered)	\$129.95

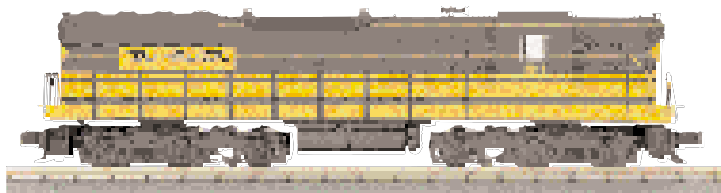

Denver Rio Grande SD9 Diesel Engine		
30-2479-1	w/Proto-Sound® 2.0	\$299.95
Denver Rio Grande SD9 Diesel Engine		
30-2479-3	(Non-Powered)	\$129.95

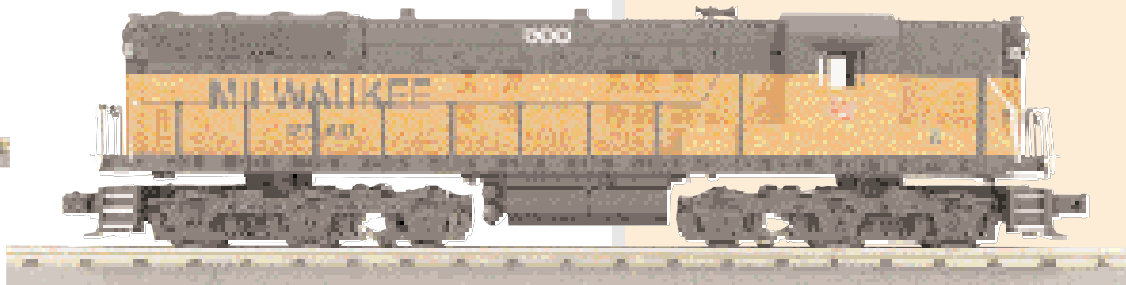

Milwaukee Road SD9 Diesel Engine		
30-2462-1	w/Proto-Sound® 2.0	\$299.95
Milwaukee Road SD9 Diesel Engine		
30-2462-3	(Non-Powered)	\$129.95

In the General Motors' Electro-Motive Division time line, 1954 holds significance for two important events. In that year, the manufacturer produced its 15,000th locomotive and introduced the 1,750-h.p. SD9. The road switcher was produced until 1959. Basically an elongated - and, some might say, handsomer - version of EMD's very popular GP9, the SD9 spread the same horsepower over two additional axles, resulting in a lower loading on each axle. This made the engine more suitable for use on light rail and in situations requiring power at low speeds, such as hump yard service.

The RailKing Scale model of the SD9 is built to 1/48th scale proportions and is thus somewhat larger than typical RailKing diesels. O gauge operators looking for scale proportioned locomotives will find durable, yet well detailed, RailKing Scale models to be an excellent alternative to more expensive O scale diesels.

Did You Know?

A special version of the SD9, called the SD9s, was a lightweight locomotive used primarily for branchline service.



Did You Know?

Compared with earlier EMD switchers, the SW1000 and SW1500 had a taller cab profile. While this aided visibility for the crew, it caused clearance problems for some industrial customers. To accommodate those users, EMD produced the SW1001 with a smaller cab to accommodate tight conditions in industrial switching areas.



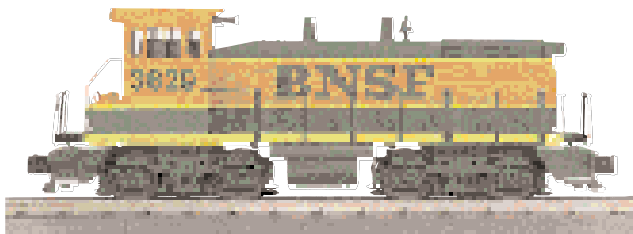

BNSF SW1500 Switcher Diesel Engine
30-2467-1 w/Proto-Sound® 2.0 \$259.95
BNSF SW1500 Switcher Diesel Engine
30-2467-3 (Non-Powered) \$129.95

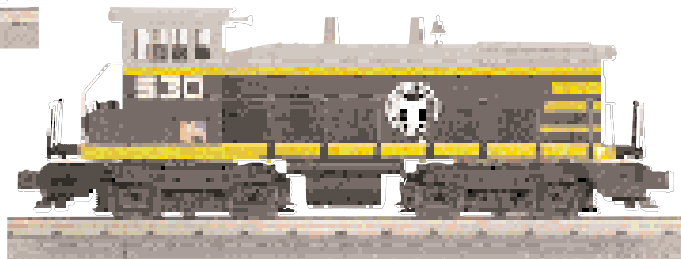

Belt Railway of Chicago SW1500 Switcher Diesel Engine
30-2466-1 w/Proto-Sound® 2.0 \$259.95
Belt Railway of Chicago SW1500 Switcher Diesel Engine
30-2466-3 (Non-Powered) \$129.95



Alaska SW1500 Switcher Diesel Engine
30-2465-1 w/Proto-Sound® 2.0 \$259.95
Alaska SW1500 Switcher Diesel Engine
30-2465-3 (Non-Powered) \$129.95

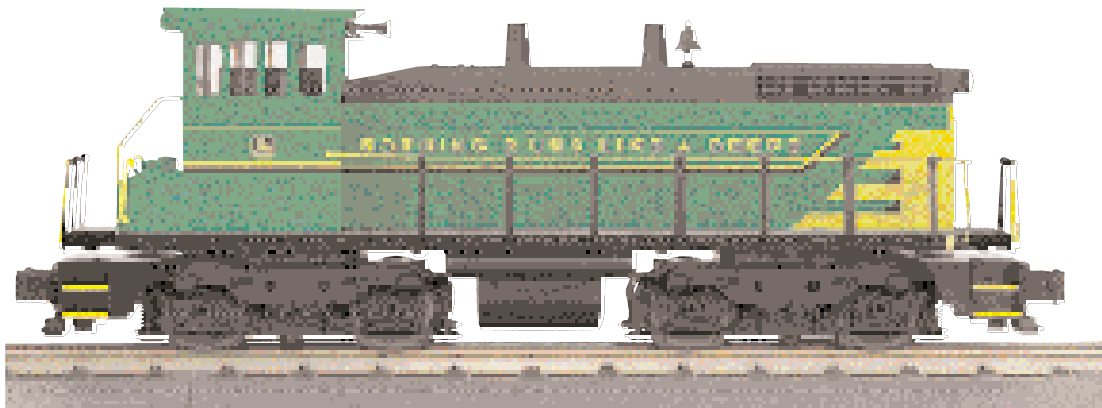

John Deere SW1500 Switcher Diesel Engine
30-2455-1 w/Proto-Sound® 2.0 \$279.95
John Deere SW1500 Switcher Diesel Engine
30-2455-3 (Non-Powered) \$139.95

John Deere is a registered trademark of Deere & Company

EMD, famous for its successful production of quality locomotives, hit the target once again when the company introduced the SW1500 and its cousin the SW1000 on January 1, 1966. These locomotives were the latest in the SW line of switchers that had been tremendously popular since the mid-1930s. Under their hoods throbbed EMD's newly-released 645E prime mover. The SW1500 sported a 12-cylinder version that developed 1500 hp, and the SW1000 featured a smaller 1000 hp, 8-cylinder version. Externally the two switchers were quite similar; a second exhaust stack and a larger radiator in the top front of the hood distinguished the SW1500, which proved to be the more popular of the two.

The list of optional equipment for the SW1500 - which included a larger fuel tank, smoother-riding trucks, and ballasting to add weight - suggests that EMD expected the locomotive to be used as a true road switcher. Many railroads did just that.

The RailKing SW1500 is sure to be an eye-catching addition to your own model railroad. Put it to work in the yard, or let it show its worth on the main line. M.T.H. is offering this handy loco in a variety of roadnames for fun and versatility, and each is equipped with the power and performance of Proto-Sound® 2.0.

NON-POWERED FEATURES

- Intricately Detailed ABS Body
- Colorful Paint Scheme
- Metal Chassis
- Die-Cast Truck Sides, Pilots and Fuel Tank
- Metal Handrails and Decorative Horn
- (2) Operating Metal Couplers
- Metal Wheels and Axles
- Unit Measures: 11 3/4" x 2 1/2" x 4"
- Operates On O-31 Curves

ADDITIONAL POWERED FEATURES

- (2) Precision Flywheel Equipped Motors
- Directionally Controlled Headlights
- (2) Remotely Controlled Proto-Couplers™
- Locomotive Speed Control
- Proto-Sound® 2.0 With The Digital Command System Featuring: Freight Yard Proto-Effects

These unique window box cars add a new dimension to your model railroad thanks to their fold up doors that reveal a secure load inside. Choose from four Harley-Davidson® cars, each loaded with a pair of 1/48th scale Harley-Davidson® motorcycles inside. Or, for that perfect gift for a new model railroading parent, select the It's a Boy or It's A Girl picture frame box cars. Show off those new baby photos under each of the car's four doors.

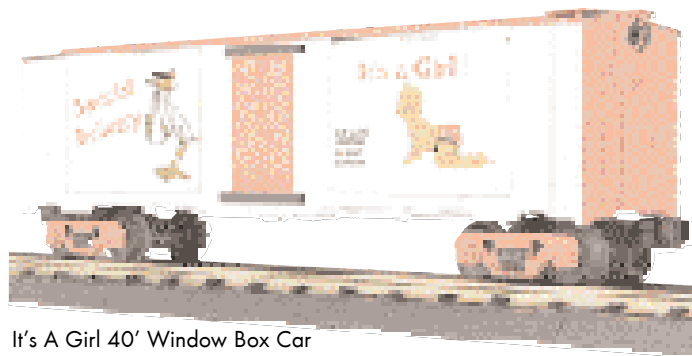

It's A Girl 40' Window Box Car
30-74201 \$59.95

PERSONALIZE YOUR BOX CAR WITH AN IMAGE!

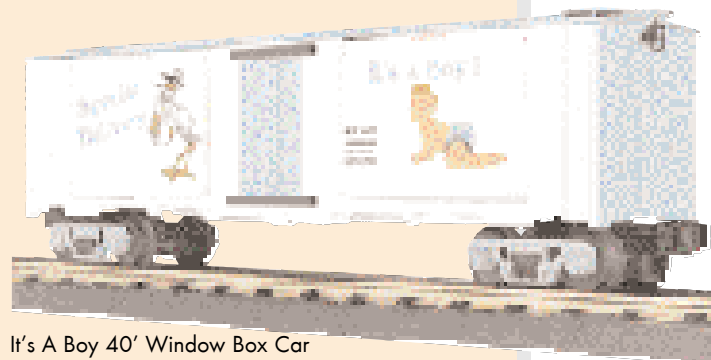
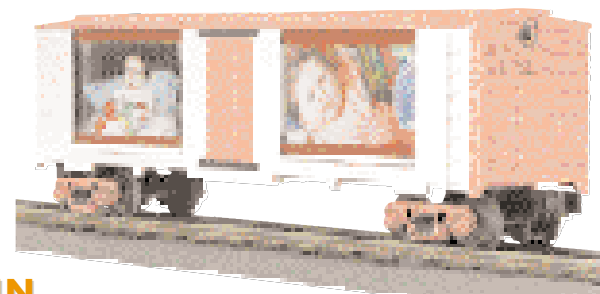

It's A Boy 40' Window Box Car
30-74200 \$59.95

YOU CAN EASILY SLIP IN YOUR OWN PHOTOGRAPHS!

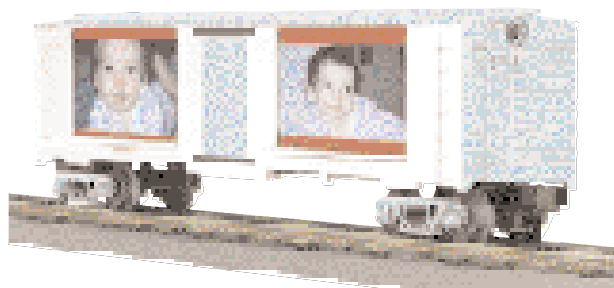

DOORS OPEN TO REVEAL PHOTO!

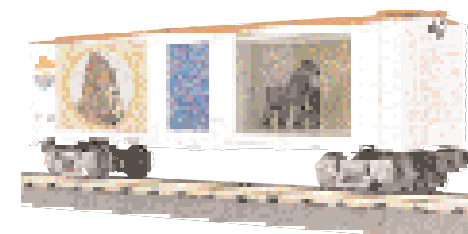

Circus (w/Gorillas) 40' Window Box Car
30-74058 \$59.95

- FEATURES**
- Intricately Detailed Durable ABS Body
 - Metal Wheels and Axles
 - Die-Cast 4-Wheel Trucks
 - Operating Die-Cast Metal Couplers
 - Colorful, Attractive Paint Schemes
 - Decorative Brake Wheels
 - Fast-Angle Wheel Sets
 - Needle-Point Axles
 - Baby Cars Feature Top & Bottom Photo Mount Guides In Each Window Area
 - Motorcycle Cars Feature (2) 1/48th Scale Motorcycles
 - (4) Opening Window Doors
 - Unit Measures: 11 3/4" x 2 1/2" x 2 3/8"
 - Operates On O-27 Curves

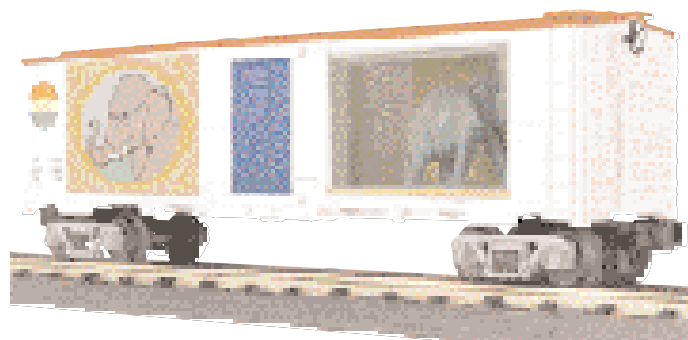

Circus (w/Elephant) 40' Window Box Car
30-74060 \$59.95

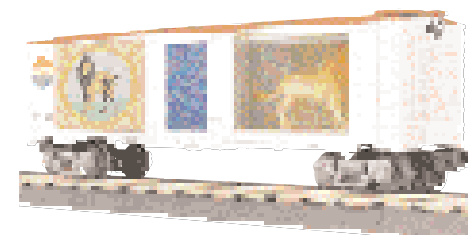

Circus (w/Lions) 40' Window Box Car
30-74059 \$59.95

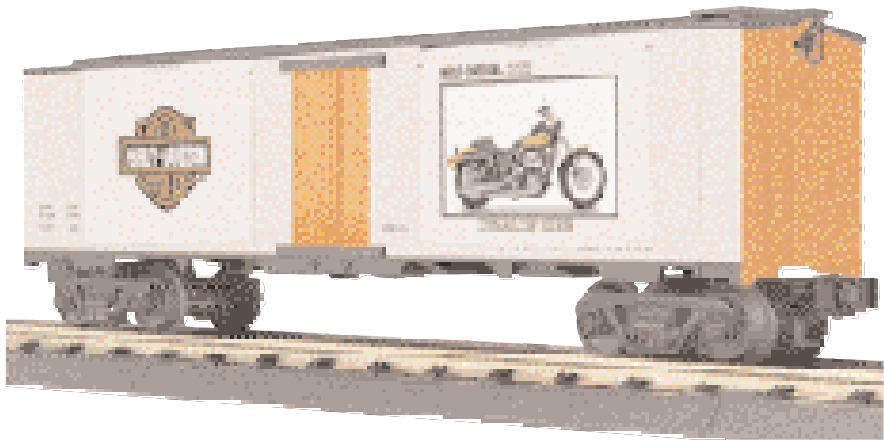

Harley-Davidson® 40' Window Box Car w/(2) Dyna Low Riders
30-74196 \$69.95

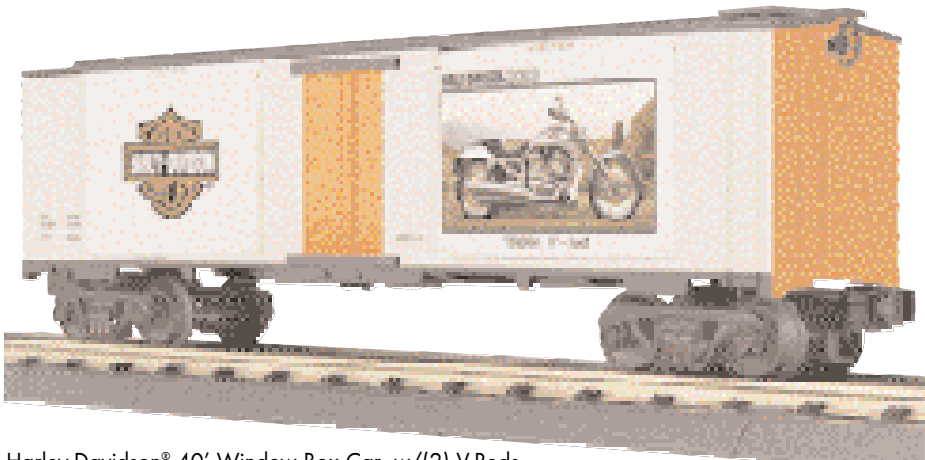

Harley-Davidson® 40' Window Box Car w/(2) V-Rods
30-74199 \$69.95



Harley-Davidson® 40' Window Box Car w/(2) Fat Boy's
30-74198 \$69.95

**EACH CAR INCLUDES
2 MOTORCYCLES!**

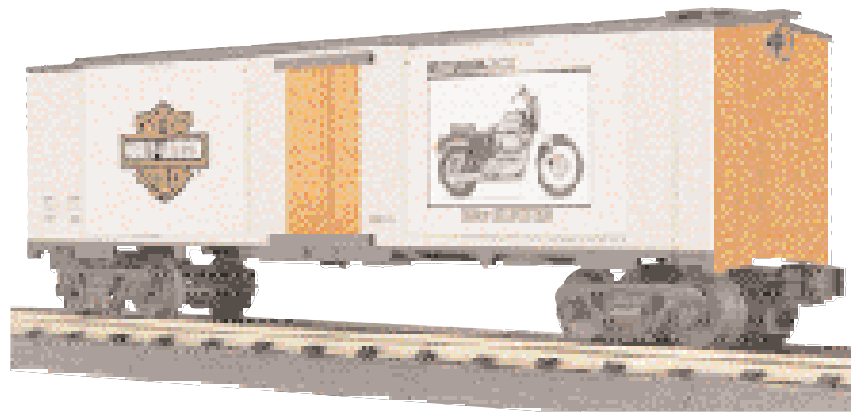

Harley-Davidson® 40' Window Box Car w/(2) Sportsters
30-74197 \$69.95



Harley-Davidson® Goods, Registered Trademark of H-D Michigan, Inc.
© H-D, All Rights Reserved

50' Dbl. Door Plugged Boxcar

An unbelievable eight different models in 326 different paint schemes have been produced by M.T.H. in our RailKing Line since 1995! O Gauge model railroaders have never had such a wide array of choices in so short a time frame from which to choose.

Each car features crisp deco, intricately detailed yet durable ABS bodies, die-cast sprung metal trucks with metal operating couplers that ensure that these cars not only look good, they'll handle the wear and tear for years to come.

In 2005, choose from 22 new schemes including a continuation of our Major League Baseball™ car series with the addition of six new team cars. Combined with the six new window box cars featured on the preceding page and it's no wonder why RailKing box cars are the most varied traditionally sized car line you can buy today.

FEATURES

- Intricately Detailed Durable ABS Bodies
- Metal Wheels and Axles
- Die-Cast 4-Wheel Trucks
- Operating Die-Cast Metal Couplers
- Colorful, Attractive Paint Schemes
- Decorative Brake Wheels
- Separate Metal Handrails
- Fast-Angle Wheel Sets
- Needle-Point Axles
- Sliding Car Doors
- Stamped Metal Floors
- Unit Measures: 13" x 2 1/2" x 3 1/2"
- Operates On O-31 Curves

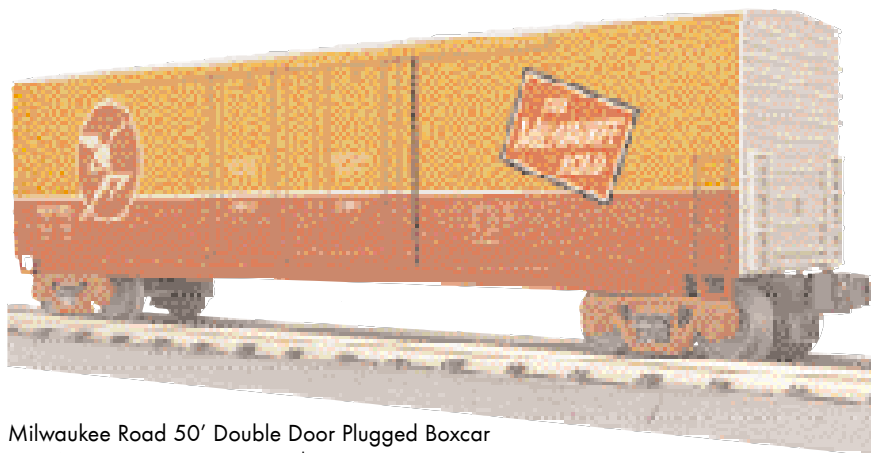

Milwaukee Road 50' Double Door Plugged Boxcar
30-74203 \$39.95

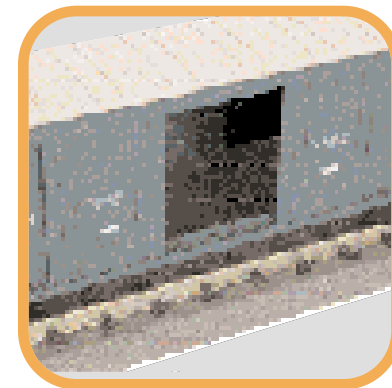

Ontario Northland 50' Double Door Plugged Boxcar
30-74204 \$39.95

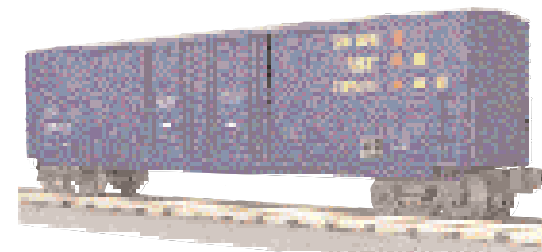

Golden West Service 50' Double Door Plugged Boxcar
30-74202 \$39.95



Southern 50' Double Door Plugged Boxcar
30-74205 \$39.95

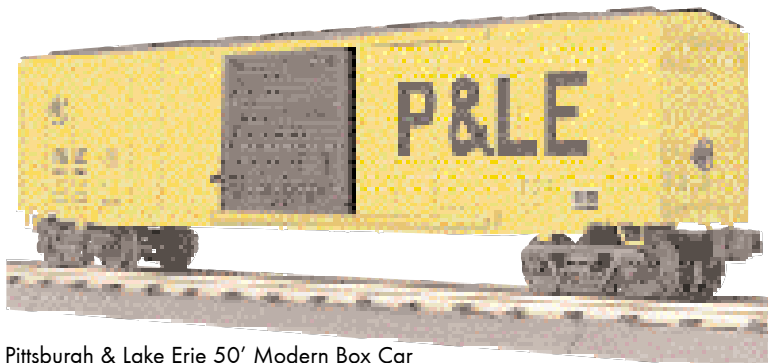

Pittsburgh & Lake Erie 50' Modern Box Car
30-74210 \$39.95

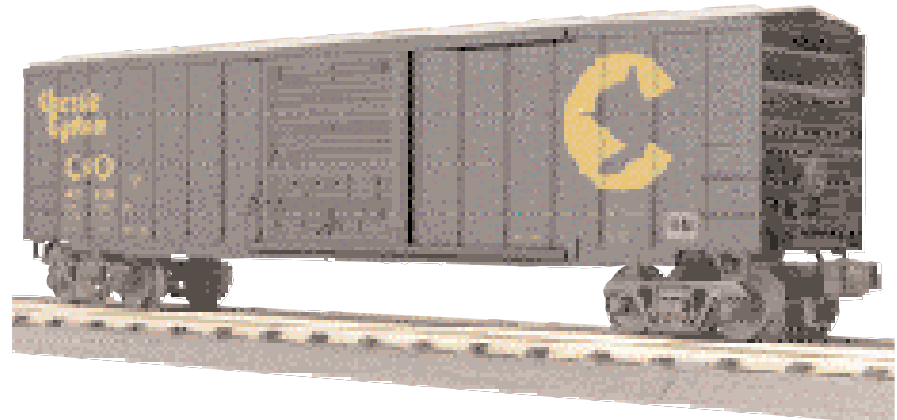

Chessie 50' Modern Box Car
30-74208 \$39.95



Norfolk Southern 50' Modern Box Car
30-74209 \$39.95



Rail Box 50' Modern Box Car
30-74207 \$39.95



FEATURES

- Intricately Detailed Durable ABS Body
- Metal Wheels and Axles
- Die-Cast 4-Wheel Trucks
- Operating Die-Cast Metal Couplers
- Colorful, Attractive Paint Schemes
- Decorative Brake Wheels
- Fast-Angle Wheel Sets
- Needle-Point Axles
- Unit Measures: 12 7/8" x 2 9/16" x 3 9/16"
- Operates On O-31 Curves

Celebrate America's pastime with this exciting collection of Major League Baseball™ box cars. Each car comes colorfully decorated with your favorite team's colors and logos. A whole series of cars began with the release of 11 teams in 2004. Now, six new cars are coming to the collection. Collect 'em all or just your favorite teams.

Major League Baseball trademarks and copyrights are used with permission of Major League Baseball Properties, Inc. MLB.com
MTH Trains/MLBP 2004



Detroit Tigers™ Boxcar
30-74215 \$39.95

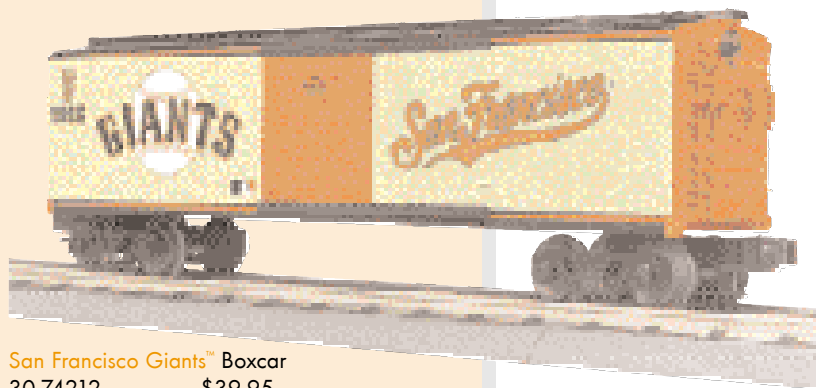

San Francisco Giants™ Boxcar
30-74212 \$39.95

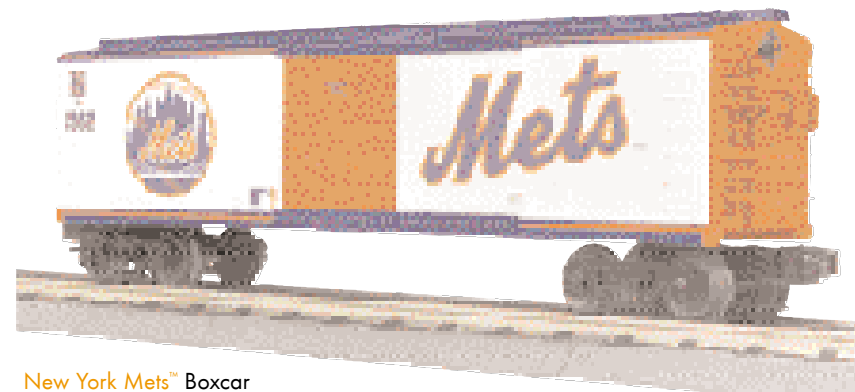

New York Mets™ Boxcar
30-74216 \$39.95

FEATURES

- Intricately Detailed Durable ABS Bodies
- Metal Wheels and Axles
- Die-Cast 4-Wheel Trucks
- Operating Die-Cast Metal Couplers
- Colorful, Attractive Paint Schemes
- Decorative Brake Wheels
- Separate Metal Handrails
- Fast-Angle Wheel Sets
- Needle-Point Axles
- Sliding Car Doors
- Unit Measures: 11 1/2" x 2 3/8" x 2 5/16"
- Stamped Metal Floors
- Operates on 0-27 Curves



Cincinnati Reds™ Boxcar
30-74213 \$39.95



Colorado Rockies™ Boxcar
30-74214 \$39.95



Seattle Mariners™ Boxcar
30-74217 \$39.95

COLLECT THEM ALL!
You can purchase any of these items at any Mega Station Retailer.

Major League Baseball trademarks and copyrights are used with permission of Major League Baseball Properties, Inc. MLB.com MTH Trains/MLBP 2004

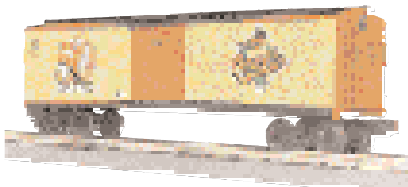

30-74173 Baltimore Orioles™ Boxcar

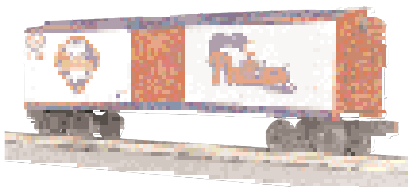

30-74181 Philadelphia Phillies™ Boxcar

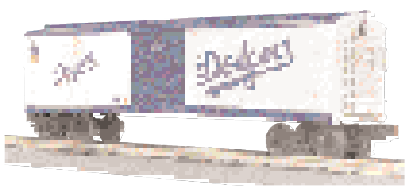

30-74178 Los Angeles Dodgers™ Boxcar

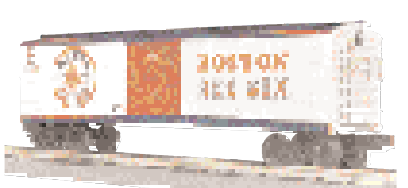

30-74174 Boston Red Sox™ Boxcar

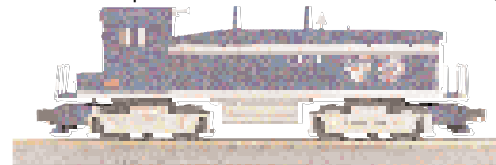

30-2443-1 Major League Baseball™
SW-9 Switcher Engine

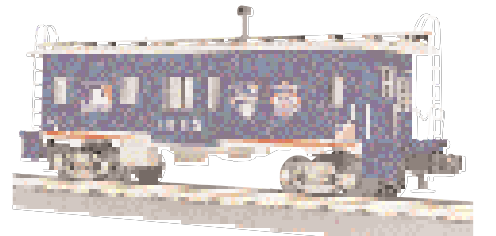

30-77044 Major League Baseball™ Bay
Window Caboose

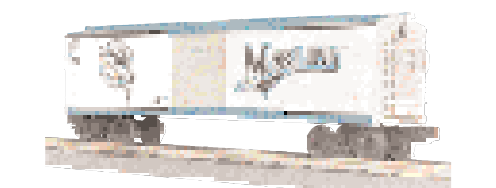

30-74177 Florida Marlins™ Boxcar

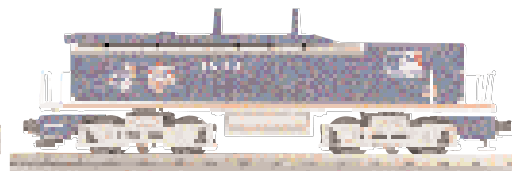

30-2443-3 Major League Baseball™
SW-9 Switcher Engine Calf



30-74182 Pittsburgh Pirates™ Boxcar



30-74180 Oakland Athletics™ Boxcar



30-74175 Chicago Cubs™ Boxcar



30-74172 Atlanta Braves™ Boxcar

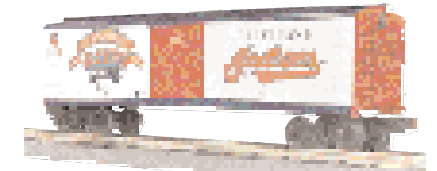

30-74176 Cleveland Indians™ Boxcar

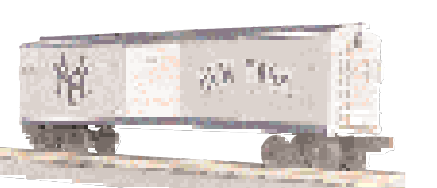

30-74179 New York Yankees™ Boxcar

High quality, traditionally sized RailKing Freight Cars provide detailed bodies and colorful paint schemes for the O Gauge railroader. MTH makes an enormous variety of RailKing Freight Cars, including many different car types and roadnames. No matter what era or part of the country you are modeling, RailKing is sure to have something for you.

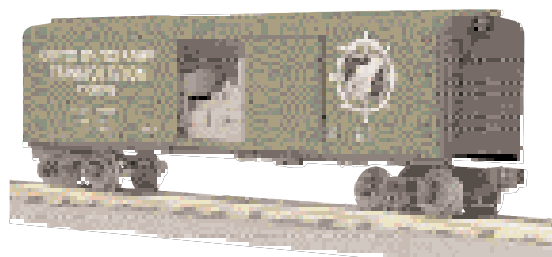

U.S. Army Rounded Roof Box Car w/Generator
30-74225 \$39.95

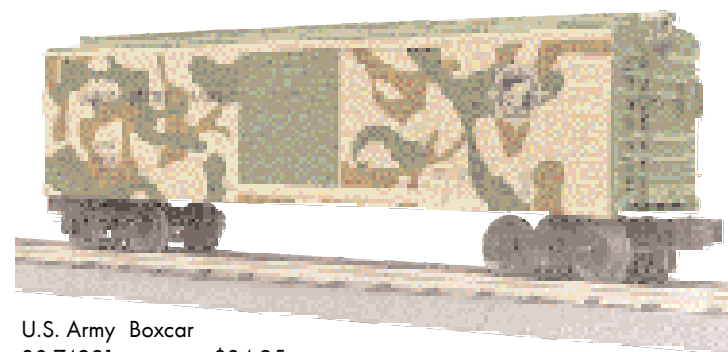

U.S. Army Boxcar
30-74221 \$34.95



Alaska Rounded Roof Box Car w/Generator
30-74222 \$39.95

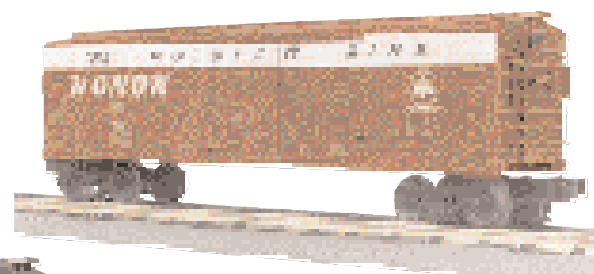

Monon Boxcar
30-74218 \$34.95

- FEATURES**
- Intricately Detailed Durable ABS Body
 - Metal Wheels and Axles
 - Die-Cast 4-Wheel Trucks
 - Operating Die-Cast Metal Couplers
 - Colorful, Attractive Paint Schemes
 - Decorative Brake Wheels
 - Separate Metal Handrails
 - Fast-Angle Wheel Sets
 - Needle-Point Axles
 - Unit Measures: 11 1/2" x 2 3/8" x 2 5/16"
 - Operates On O-27 Curves

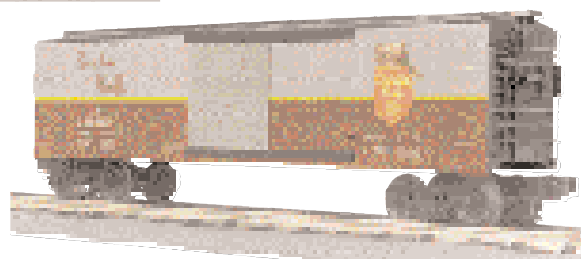

Canadian Pacific Boxcar
30-74211 \$34.95

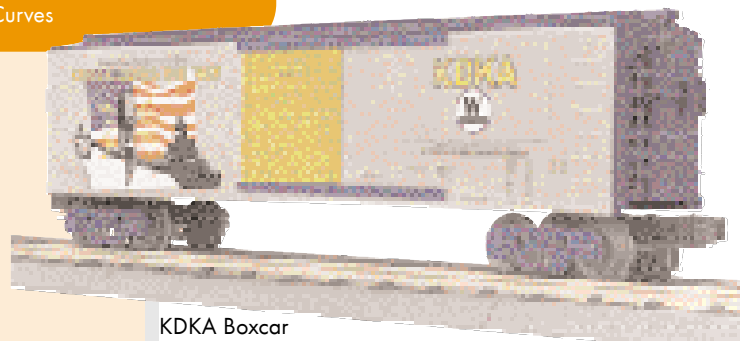

KDKA Boxcar
30-74227 \$39.95

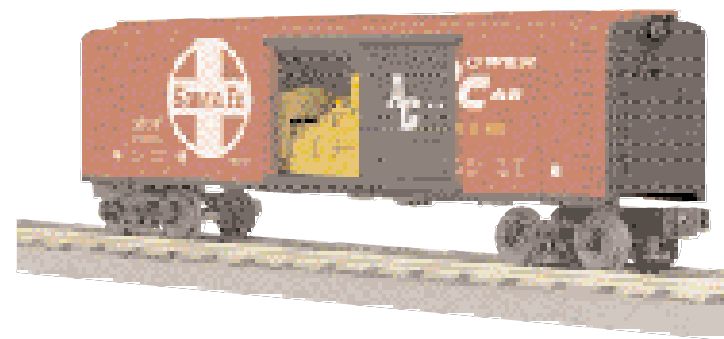

Santa Fe Rounded Roof Box Car w/Generator
30-74224 \$39.95



Creamside™ Modern Reefer Car
30-7889 \$39.95

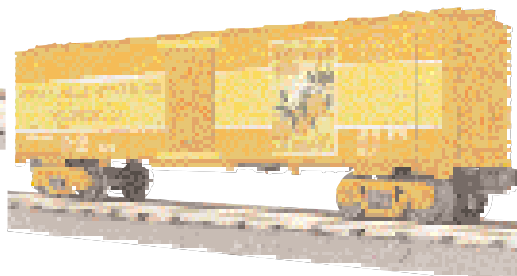

Orange Blossom Amber™ Modern Reefer Car
30-7888 \$39.95



Bad Frog Beer™ Modern Reefer Car
30-7886 \$39.95

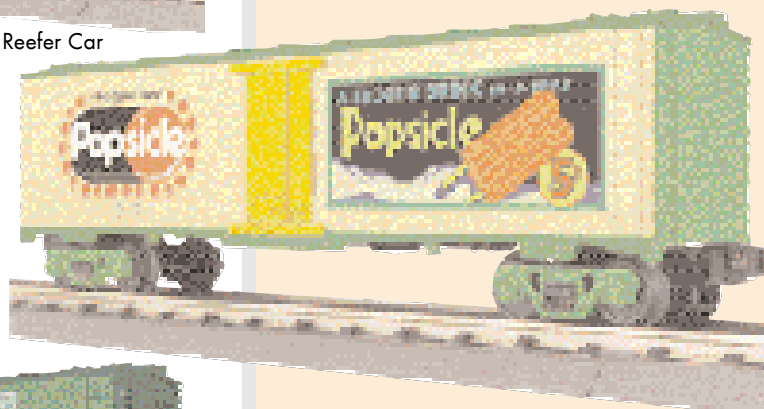

Popsicle™ Modern Reefer Car
30-7890 \$39.95



Irish Green Ale™ Modern Reefer Car
30-7887 \$39.95



Top Hat Beer™ Modern Reefer Car
30-7891 \$39.95

Nothing advertises a product like a colorful reefer car and nobody offers more roadname variety than those found in the RailKing line. Visit the M.T.H. website for a quick search of the 128 different paint schemes available in four RailKing Reefer car styles or choose from any of the six new schemes coming in 2005.

FEATURES

- Intricately Detailed Durable ABS Bodies
- Metal Wheels and Axles
- Die-Cast 4-Wheel Trucks
- Operating Die-Cast Metal Couplers
- Colorful, Attractive Paint Schemes
- Separate Metal Handrails
- Fast-Angle Wheel Sets
- Needle-Point Axles
- Unit Measures: 11 1/2" x 2 3/8" x 2 5/16"
- Operates On O-27 Curves

4-Bay Cylindrical Hopper Car

Like reefer cars, hopper cars - especially the more modern varieties - make great "canvasses" for colorful paint schemes. M.T.H.'s RailKing line has long history of producing colorful hopper cars. In fact over 135 different schemes have appeared on RailKing hopper cars since 1995. In 2005, eight more schemes will be available from which to choose.

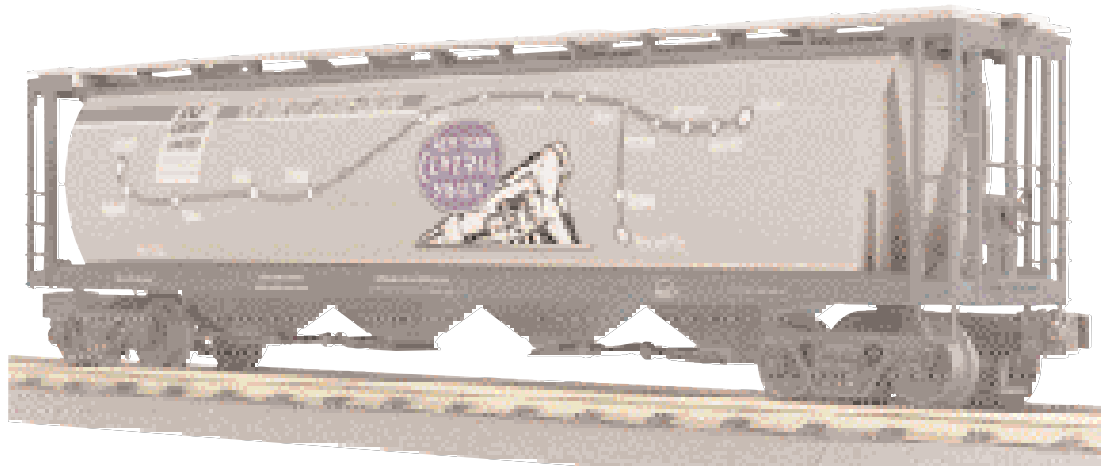

New York Central 4-Bay Cylindrical Hopper Car
30-75177 \$39.95

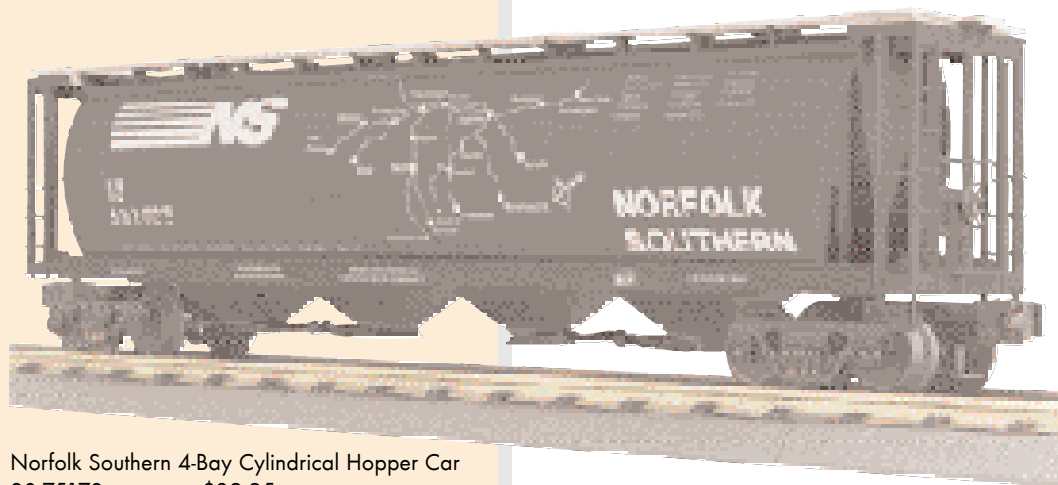

Norfolk Southern 4-Bay Cylindrical Hopper Car
30-75178 \$39.95

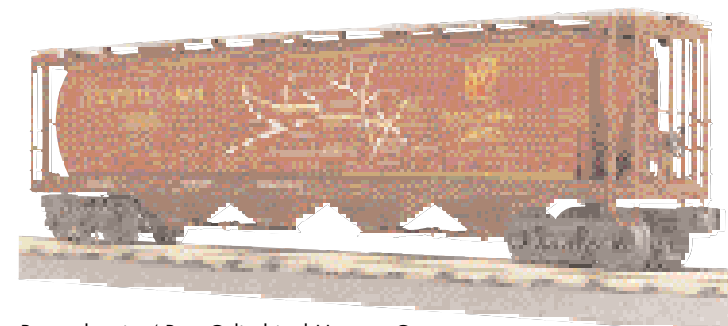

Pennsylvania 4-Bay Cylindrical Hopper Car
30-75179 \$39.95



Great Northern 4-Bay Cylindrical Hopper Car
30-75176 \$39.95

FEATURES

- Intricately Detailed Durable ABS Body
- Metal Wheels and Axles
- Die-Cast 4-Wheel Trucks
- Operating Die-Cast Metal Couplers
- Colorful, Attractive Paint Schemes
- Decorative Brake Wheels
- Separate Metal Handrails
- Fast-Angle Wheel Sets
- Needle-Point Axles
- Unit Measures: 13 3/8" x 2 3/8" x 3 7/16"
- Operates On O-31 Curves



Santa Fe 4-Bay Hopper Car
30-75182 \$34.95



Western Maryland 4-Bay Hopper Car
30-75183 \$34.95



Denver Rio Grande 4-Bay Hopper Car
30-75181 \$34.95

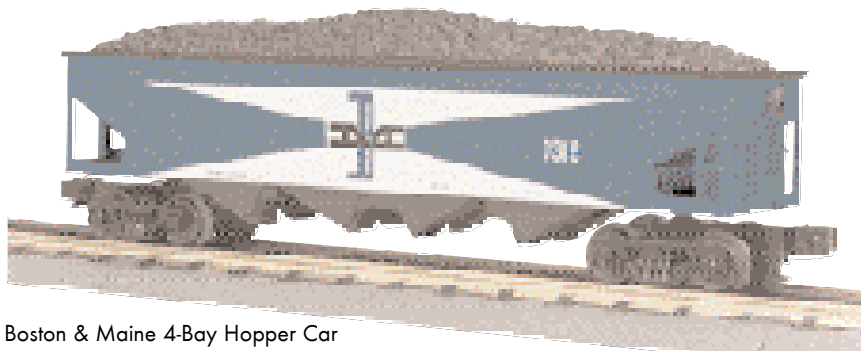

Boston & Maine 4-Bay Hopper Car
30-75180 \$34.95

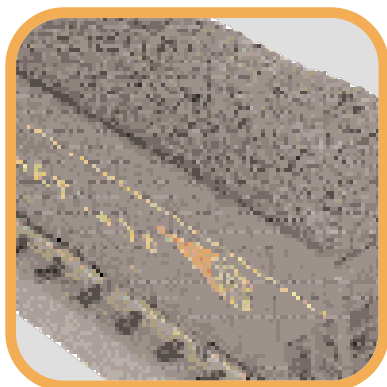

FEATURES

- Intricately Detailed Durable ABS Body
- Metal Wheels and Axles
- Die-Cast 4-Wheel Trucks
- Operating Die-Cast Metal Couplers
- Colorful, Attractive Paint Schemes
- Decorative Brake Wheels
- Separate Metal Handrails
- Fast-Angle Wheel Sets
- Needle-Point Axles
- Unit Measures: 11 3/4" x 2 1/2" x 2 3/4"
- Operates On O-27 Curves

Six different models in over 160 different paint schemes have appeared in the RailKing tank car category over the past nine years. Like all RailKing rolling stock, each car features crisp deco, intricately detailed yet durable bodies and die-cast sprung metal trucks with metal operating couplers.

Over the next two pages, we've added eight new paint schemes to our roster. When compared with other tank cars on the market, you won't find a better detailed more durable model from anyone because RailKing freight cars are great looking and built to last.



Air Force Modern Tank Car
30-73140 \$39.95

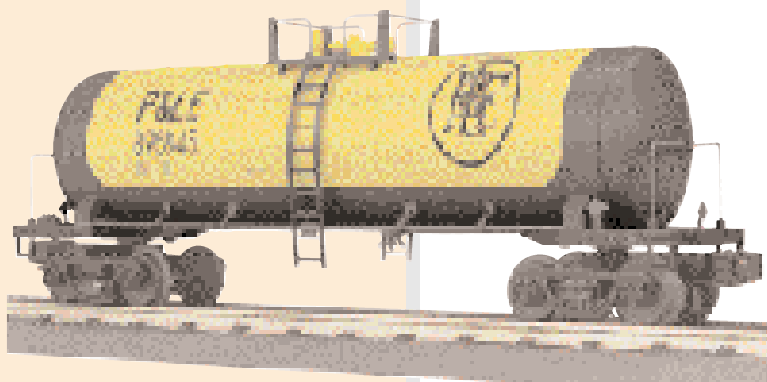

Pittsburgh & Lake Erie Modern Tank Car
30-73142 \$39.95

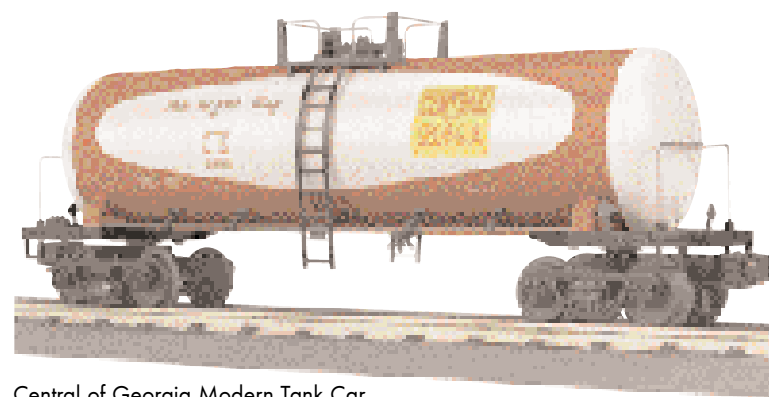

Central of Georgia Modern Tank Car
30-73141 \$39.95

- FEATURES**
- Intricately Detailed Durable ABS Body
 - Metal Wheels and Axles
 - Die-Cast 4-Wheel Trucks
 - Operating Die-Cast Metal Couplers
 - Colorful, Attractive Paint Schemes
 - Separate Metal Handrails
 - Fast-Angle Wheel Sets
 - Needle-Point Axles
 - Unit Measures: 10 7/8" x 2 3/8" x 3 7/8"
 - Operates On O-27 Curves



State of Maine Modern Tank Car
30-73143 \$39.95



Texas Special Tank Car
30-73146 \$39.95

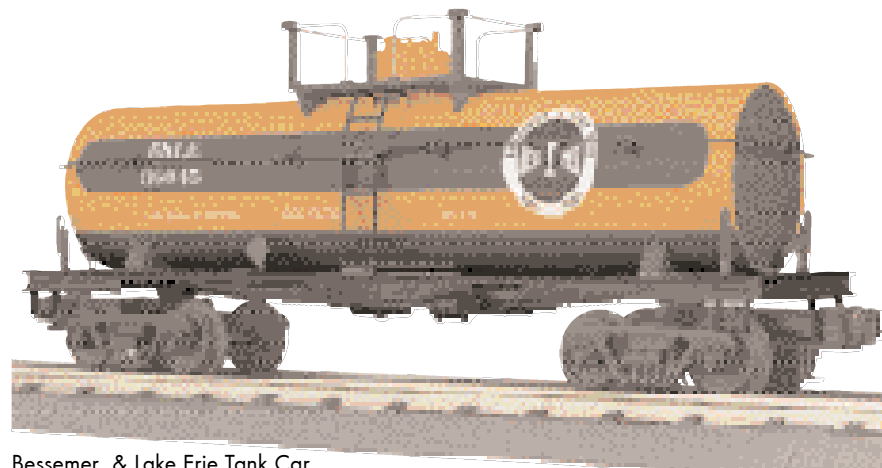

Bessemer & Lake Erie Tank Car
30-73144 \$39.95

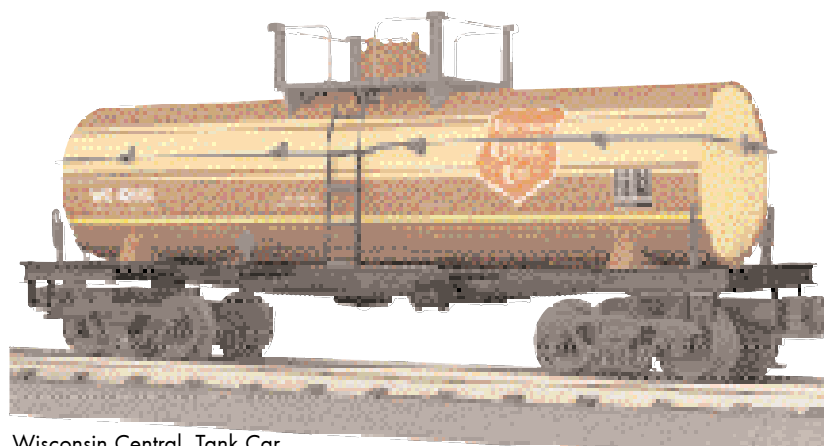

Wisconsin Central Tank Car
30-73147 \$39.95

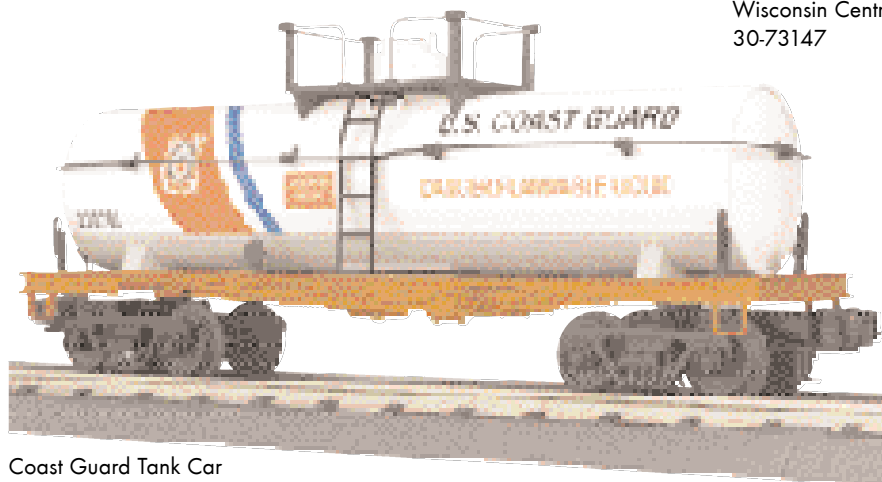

Coast Guard Tank Car
30-73145 \$39.95

FEATURES

- Intricately Detailed Durable ABS Body
- Metal Wheels and Axles
- Die-Cast 4-Wheel Trucks
- Operating Die-Cast Metal Couplers
- Colorful, Attractive Paint Schemes
- Decorative Brake Wheels
- Separate Metal Handrails
- Fast-Angle Wheel Sets
- Needle-Point Axles
- Unit Measures: 10 3/8" x 2 3/8" 3 13/16"
- Operates On O-27 Curves

A somewhat rare car in the RailKing product line, the Ore Car has only been produced in 19 different paint schemes since its introduction to the line in 1998. During that same time, three different models of stock cars in over 60 paint schemes have appeared, each featuring crisp deco, intricately detailed yet durable bodies and die-cast sprung metal trucks with metal operating couplers.

In 2005 we've added four new paint schemes to both our Ore Car and Stock Car rosters. When compared with other ore cars on the market, you won't find a better detailed, more durable model, that looks great on both traditional or scale railroads.



Pennsylvania Ore Car
30-75173 \$34.95



Southern Pacific Ore Car
30-75175 \$34.95



Soo Line Ore Car
30-75174 \$34.95



Ontario Northland Ore Car
30-75172 \$34.95

FEATURES

- Intricately Detailed Durable ABS Body
- Metal Wheels and Axles
- Die-Cast 4-Wheel Trucks
- Operating Die-Cast Metal Couplers
- Colorful, Attractive Paint Schemes
- Decorative Brake Wheels
- Fast-Angle Wheel Sets
- Needle-Point Axles
- Unit Measures: 7 1/8" x 2 9/16" x 3 5/16"
- Operates On O-27 Curves

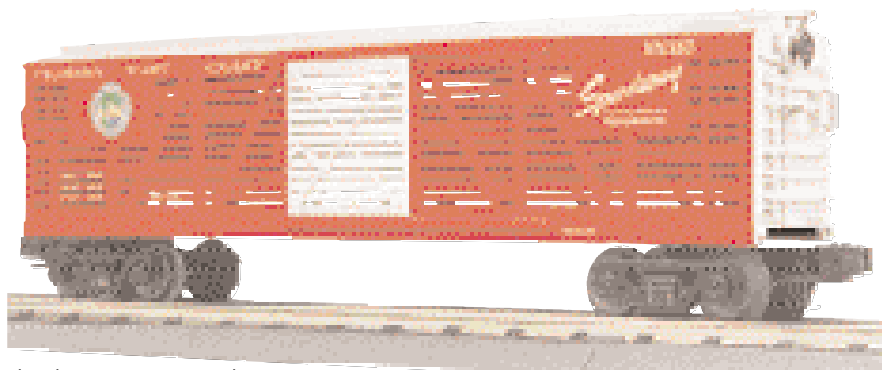

Florida East Coast Stock Car
30-7150 \$34.95

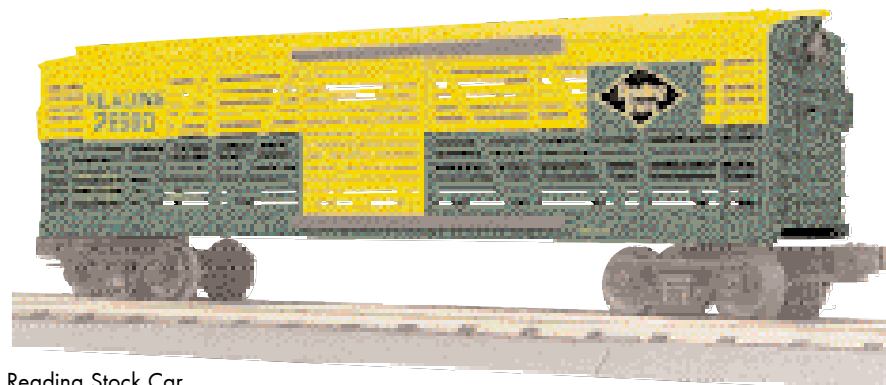

Reading Stock Car
30-7152 \$34.95

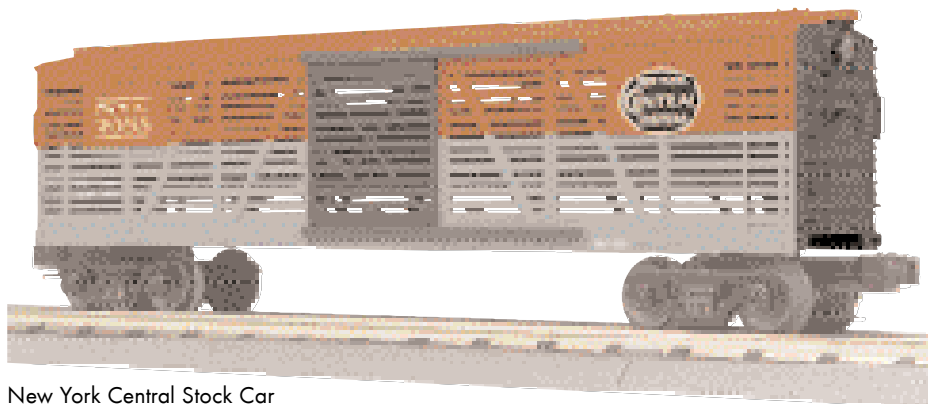

New York Central Stock Car
30-7151 \$34.95

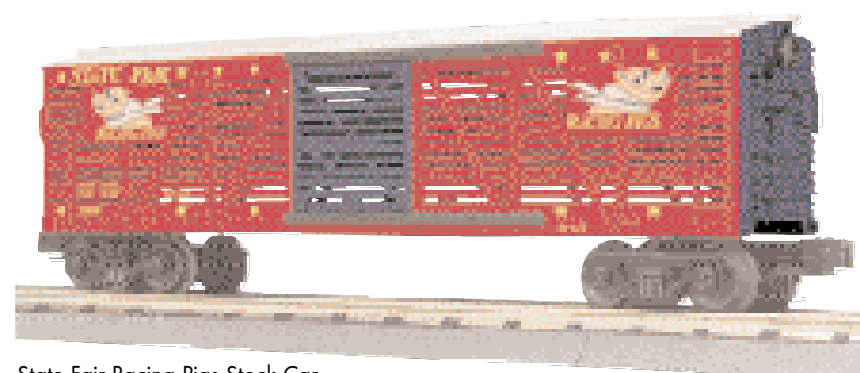

State Fair Racing Pigs Stock Car
30-7153 \$34.95



FEATURES

- Intricately Detailed Durable ABS Body
- Metal Wheels and Axles
- Die-Cast 4-Wheel Trucks
- Operating Die-Cast Metal Couplers
- Colorful, Attractive Paint Schemes
- Decorative Brake Wheels
- Separate Metal Handrails
- Fast-Angle Wheel Sets
- Needle-Point Axles
- Opening Car Doors
- Unit Measures: 11 5/8" x 2 1/2" x 3 3/8"
- Operates On O-27 Curves

Maintenance of Way (M.O.W.) is an important part of railroad maintenance and can't be accomplished without heavy lifting equipment. Recreate your M.O.W. needs with RailKing Fire Cars, Crane and Crane Tender Cars.

Since 1997, M.T.H. has produced 74 different RailKing crane & crane tender cars! Each crane can be manually operated and both the crane and the tender car feature operating interior lights.

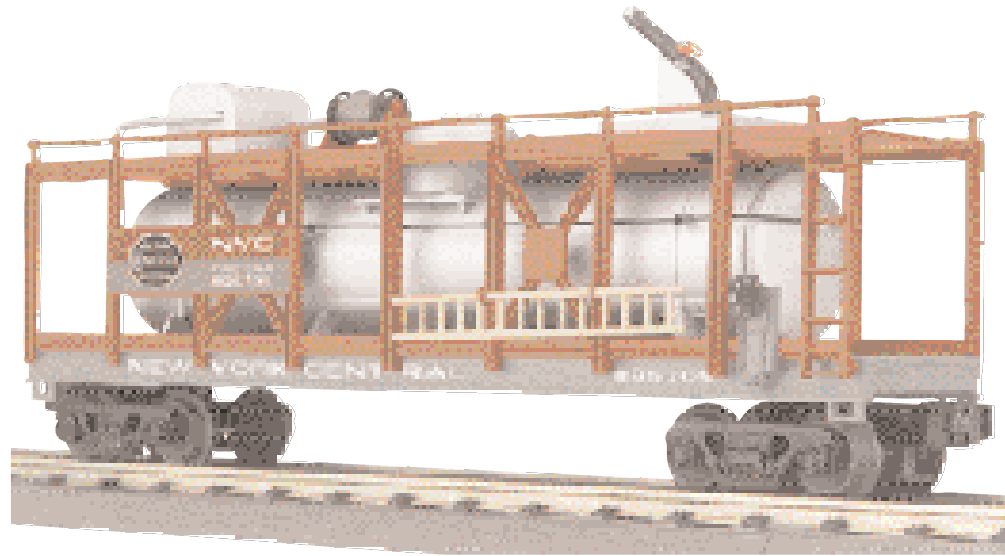

New York Central Fire Car
30-79088 \$49.95

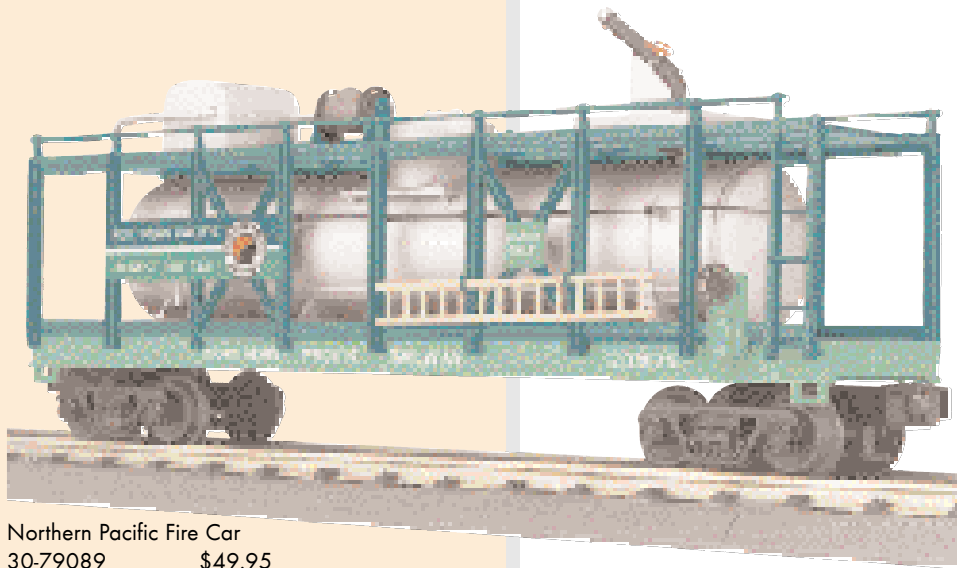

Northern Pacific Fire Car
30-79089 \$49.95

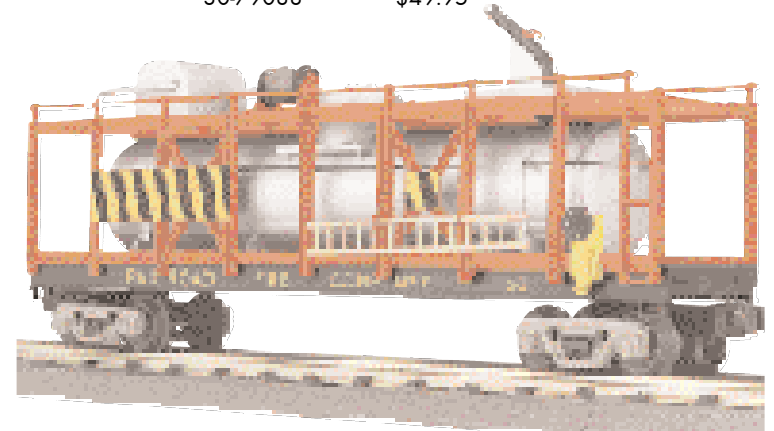

Railroad Fire Company 52 Fire Car
30-79090 \$49.95

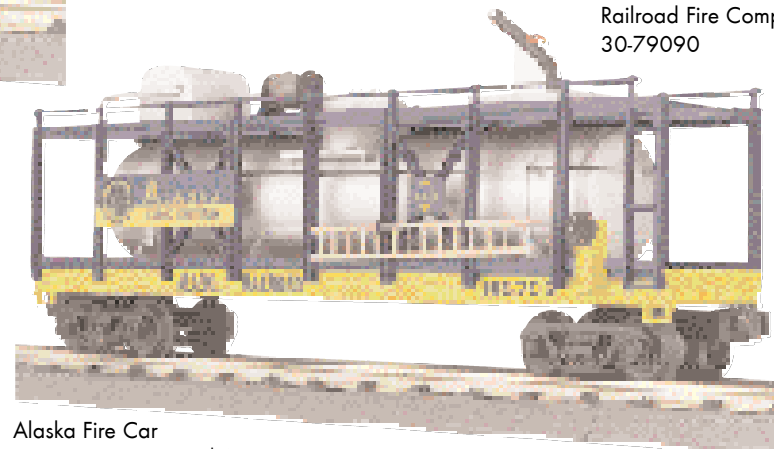

Alaska Fire Car
30-79087 \$49.95

FEATURES

- Intricately Detailed Durable ABS Body
- Metal Wheels and Axles
- Die-Cast 4-Wheel Trucks
- Operating Die-Cast Metal Couplers
- Colorful, Attractive Paint Schemes
- Fast-Angle Wheel Sets
- Needle-Point Axles
- Unit Measures: 11 11/16" x 2 5/16" x 4 3/4"
- Operates On O-27 Curves



Bessemer & Lake Erie American Crane Car
30-79101 \$59.95

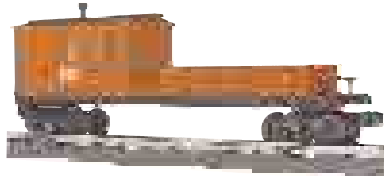

Bessemer & Lake Erie Crane Tender Car
30-79105 \$39.95

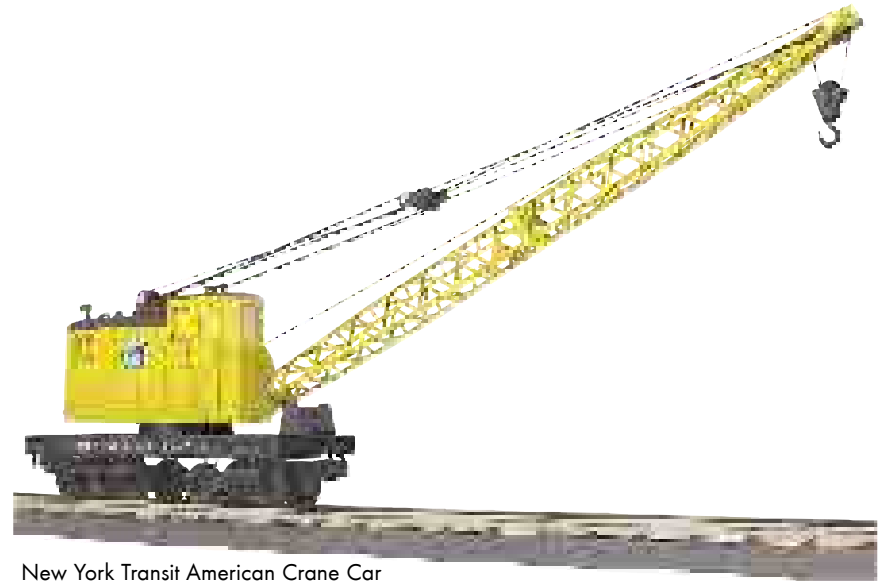

New York Transit American Crane Car
30-79102 \$59.95

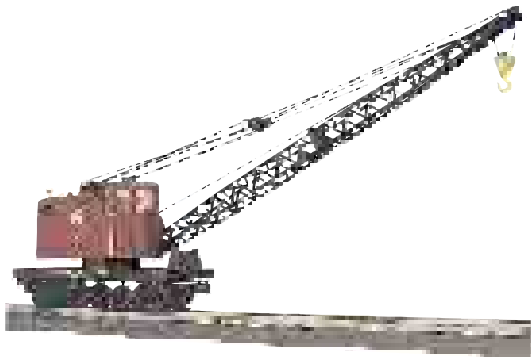

Pennsylvania American Crane Car
30-79103 \$59.95

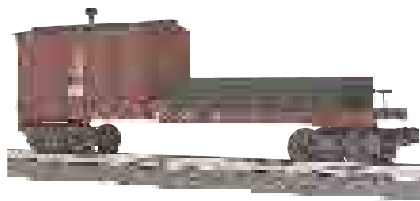

Pennsylvania Crane Tender Car
30-79107 \$39.95

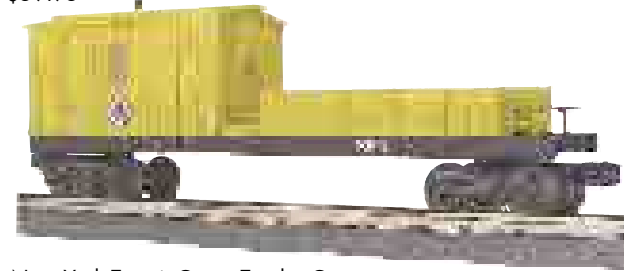

New York Transit Crane Tender Car
30-79106 \$39.95

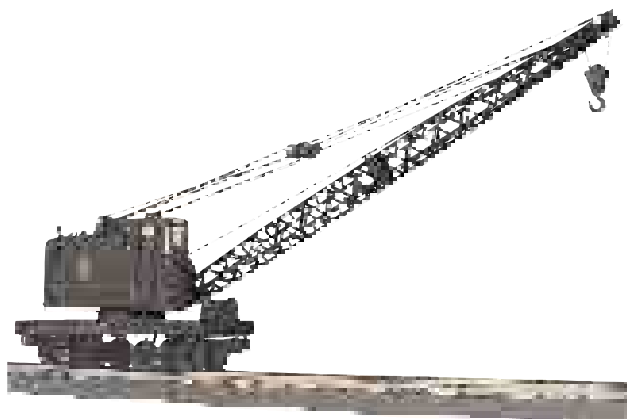

Baltimore & Ohio American Crane Car
30-79100 \$59.95

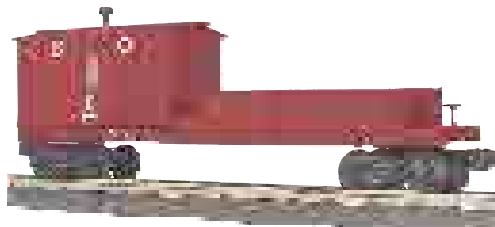

Baltimore & Ohio Crane Tender Car
30-79104 \$39.95

FEATURES

- Intricately Detailed Durable ABS Body
- Metal Wheels and Axles
- Die-Cast 4-Wheel Trucks
- Operating Die-Cast Metal Couplers
- Colorful, Attractive Paint Schemes
- Decorative Brake Wheels
- Fast-Angle Wheel Sets
- Needle-Point Axls

American Crane Car

- Manually Operated Crane Hook & Boom
- Unit Measures: 17 5/8" x 2 5/8" x 4"
- Operates On O-31 Curves

Crane Tender Car:

- Operating Interior Lighting
- Unit Measures: 11 1/2" x 2 5/16" x 4"
- Operates On O-27 Curves

Sitting at a crossing and waiting for a freight train to clear and you're likely to see a lot of flat cars passing you by. Plain in nature but incredibly diverse in ability, the lowly flat car is one of railroading's most popular cars. Since 1995, over 230 flat cars have appeared in the RailKing product line. In 2005, you can choose from 15 new cars - each equipped with a unique load.

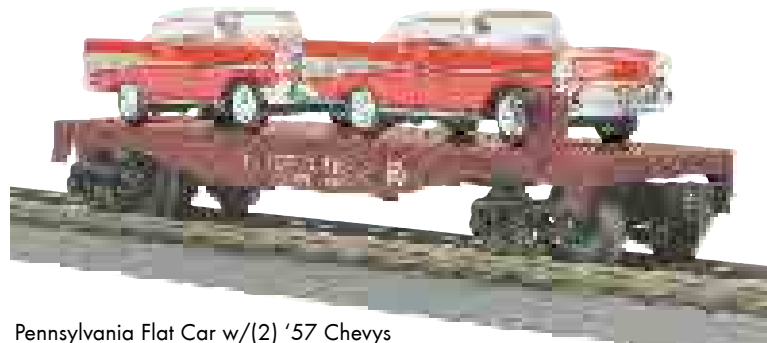

Pennsylvania Flat Car w/(2) '57 Chevys
30-76164 \$39.95

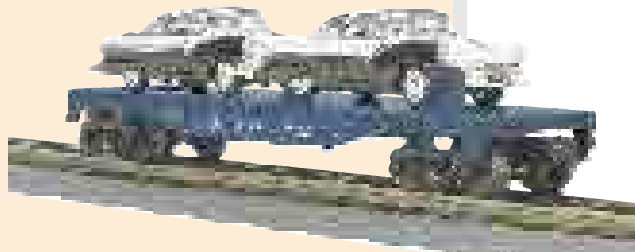

Baltimore & Ohio Flat Car w/(2) '55 Fords
30-76163 \$39.95



Chesapeake & Ohio Flat Car w/(2) 1949 Buick Roadmasters
30-76118 \$39.95

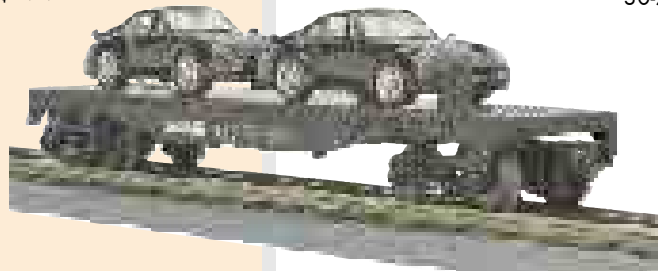

Norfolk Southern Flat Car w/(2) 993 Porsches
30-76165 \$39.95

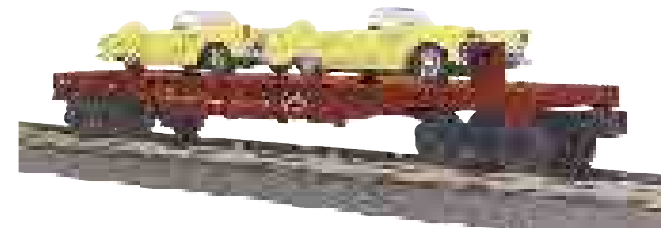

New York Central Flat Car w/(2) 1956 Ford Thunderbirds
30-76119 \$39.95



Union Pacific Flat Car w/(2) SL55 Mercedes
30-76167 \$39.95

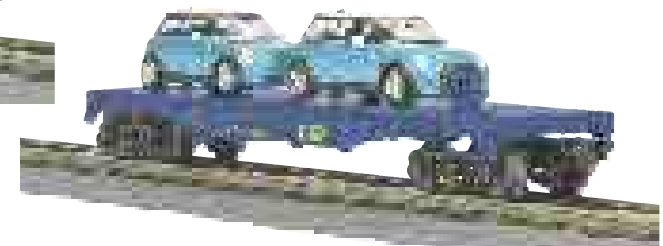

CSX Flat Car w/(2) Mini Coopers
30-76166 \$39.95

FEATURES

- Intricately Detailed Durable ABS Body
- Metal Wheels and Axles
- Die-Cast 4-Wheel Trucks
- Operating Die-Cast Metal Couplers
- Colorful, Attractive Paint Schemes
- Decorative Brake Wheels
- Fast-Angle Wheel Sets
- Needle-Point Axles
- (2) Maryland Police Cars
- Unit Measures: 11 3/4" x 2 5/16" x 1 15/16"
- Operates On O-27 Curves

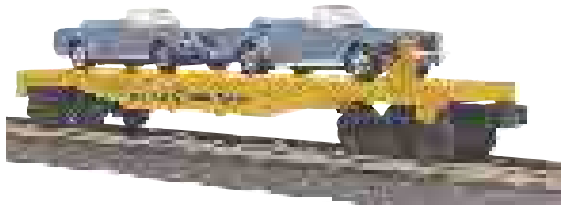

Chessie Flat Car w/(2) 1964 Mustang Convertible
30-76120 \$39.95



Southern Flat Car w/(2) 3100 Chevy Shell Pickup Truck
30-76123 \$39.95



Santa Fe Flat Car w/(2) 1969 Chevy Corvettes
30-76121 \$39.95



Milwaukee Road Flat Car w/(2) 3100 Chevy Chevron Pickup Truck
30-76122 \$39.95



U.S. Army Flat Car w/(2) Willy's Jeeps
30-76125 \$39.95



U.S. Army Flat Car w/(2) Willy's Jeeps
30-76124 \$39.95



Chicago and Northwestern Auto Carrier Flat Car w/(4) '59 Cadillacs
30-76139 \$59.95



Southern Auto Carrier Flat Car w/(4) '55 Pontiacs
30-76140 \$59.95



Florida East Coast Flat Car - w/Bulkheads & Pipe Load
30-76159 \$34.95



Union Pacific Flat Car w/ Billboard
30-76155 \$34.95



Chessie Flat Car - w/Bulkheads & Pipe Load
30-76160 \$34.95



New York Central Flat Car - w/Bulkheads & Pipe Load
30-76161 \$34.95

FEATURES

- Intricately Detailed Durable ABS Body
- Metal Wheels and Axles
- Die-Cast 4-Wheel Trucks
- Operating Die-Cast Metal Couplers
- Colorful, Attractive Paint Schemes
- Decorative Brake Wheels
- Fast-Angle Wheel Sets
- Needle-Point Axles
- (9) Piece Pipe Load
- Unit Measures: 13" x 2 3/8" x 3 1/2"
- Operates On O-31 Curves

FlatCar w/ Billboard

- Removable 2-Sided Billboard
- Unit Measures: 11 5/8" x 2 1/4" x 3 5/8"
- Operates On O-27 Curves



Texas Special Flat Car - w/Bulkheads & Pipe Load
30-76162 \$34.95



Harley-Davidson® Flat Car w/ Trailer
30-76157 \$49.95

 Harley-Davidson® Goods, Registered Trademark of H-D Michigan, Inc.
© H-D, All Rights Reserved



Union Pacific Flat Car w/ Trailer
30-76154 \$39.95



Canadian Pacific Flat Car w/ Trailer
30-76156 \$39.95



Caterpillar Flat Car w/ Trailer
30-76146 \$49.95

©2004 CATERPILLAR
CAT, Caterpillar, and their design marks are registered trademarks of Caterpillar, Inc.

FEATURES

- Intricately Detailed Durable ABS Body
- Metal Wheels and Axles
- Die-Cast 4-Wheel Trucks
- Operating Die-Cast Metal Couplers
- Colorful, Attractive Paint Schemes
- Decorative Brake Wheels
- Fast-Angle Wheel Sets
- Needle-Point Axles
- ABS Detailed Trailer
- Unit Measures: 11 5/8" x 2 1/4" x 3 3/4"
- Operates On O-27 Curves

Perhaps the most famous of all rolling stock, the caboose is a distant memory for railroad's today having long since been replaced by modern technology. But the caboose lives on in the memories of many housing much of the romance of railroading. Within the RailKing line, more than 169 different paint schemes have been created since 1995. This year choose from 12 additional schemes in three different models.



Alaska Bay Window Caboose
30-77064 \$49.95



Norfolk Southern Bay Window Caboose
30-77067 \$49.95



Canadian Pacific Bay Window Caboose
30-77065 \$49.95



Great Northern Bay Window Caboose
30-77066 \$49.95

FEATURES

- Intricately Detailed Durable ABS Body
- Metal Wheels and Axles
- Die-Cast 4-Wheel Trucks
- Operating Die-Cast Metal Couplers
- Colorful, Attractive Paint Schemes
- Decorative Brake Wheels
- Fast-Angle Wheel Sets
- Needle-Point Axles
- Operating Interior Lighting
- Unit Measures: 10 5/8" x 2 3/4" x 3 11/16"
- Operates On O-27 Curves



John Deere Offset Steel Caboose
30-77063 \$54.95
John Deere is a registered trademark of Deere & Company



Susquehanna Offset Steel Caboose
30-77073 \$49.95



Bessemer & Lake Erie Offset Steel Caboose
30-77072 \$49.95



Western Maryland Offset Steel Caboose
30-77074 \$49.95



Pennsylvania Bobber Caboose
30-77070 \$39.95



BNSF Bobber Caboose
30-77069 \$39.95



Belt Railway of Chicago Bobber Caboose
30-77068 \$39.95



Virginian Bobber Caboose
30-77071 \$39.95

FEATURES

- Intricately Detailed Durable ABS Body
- Metal Wheels and Axles
- Die-Cast 2-Wheel Trucks
- Operating Die-Cast Metal Couplers
- Colorful, Attractive Paint Schemes
- Fast-Angle Wheel Sets
- Needle-Point Axles
- Near-Scale Proportions
- Operating Interior Lighting
- Operates On O-27 Curves
- Unit Measures: 6 5/8" x 2 5/8" x 3 1/2"

OFFSET STEEL CABOOSE

- Unit Measures: 10 1/4" x 2 1/2" x 4 1/4"

RailKing operating freight cars add a new dimension and excitement level to your O Gauge layout with realistic action and quiet smooth operation in a way other operating cars cannot.

Each car comes to life when parked on an operating track section. When the track section is activated, the signal man will emerge from the opening car door with his lantern lit. Both the operating log and dump cars feature a die-cast chassis which houses a motorized mechanism that rocks the body up and drops the side to release the load. The realistic operation will bring to life your railroad's operations.

You can see each of these cars operate by visiting the M.T.H. website (www.mthtrains.com) and click on the Video Link located right on the home page.



Caterpillar Dump Car w/Operating Bay
30-79084 \$54.95

©2004 CATERPILLAR
CAT, Caterpillar, and their design marks are registered trademarks of Caterpillar, Inc.



Chessie Dump Car w/Operating Bay
30-79085 \$49.95



Pennsylvania Operating Log Dump Car
30-79092 \$54.95

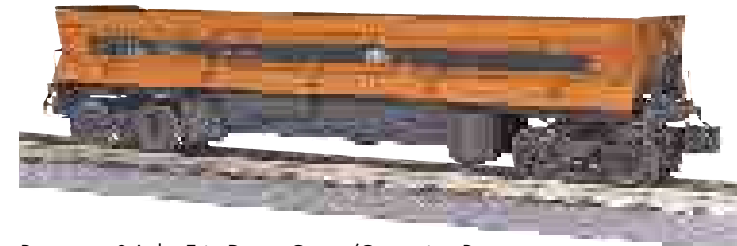

Bessemer & Lake Erie Dump Car w/Operating Bay
30-79086 \$49.95

FEATURES

- Durable ABS Intricately Detailed Bodies
- Metal Wheels and Axles
- Die-Cast 4-Wheel Trucks
- Operating Die-Cast Metal Couplers
- Colorful, Attractive Paint Schemes
- Operates On O-31 Track
- Decorative Brake Wheels
- Fast-Angle Wheel Sets
- Needle-Point Axles
- Unit Measures: 12" x 2 5/8" x 2 7/16"
- Operates On O-31 Curves



Alaska Operating Log Dump Car
30-79091 \$54.95

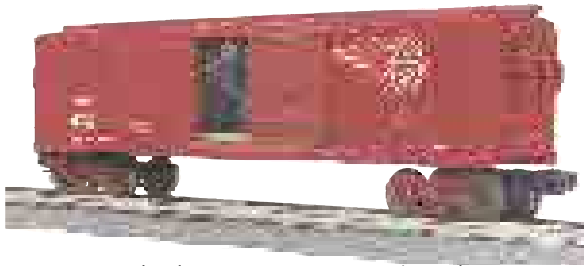

Western Maryland Operating Box Car w/Signal Man
30-79095 \$59.95



Santa Fe Operating Box Car w/Signal Man
30-79094 \$59.95



New York Transit Operating Box Car w/Signal Man
30-79093 \$59.95



Pennsylvania Operating Rotary Snow Plow
30-79097 \$59.95



Christmas Operating Rotary Snow Plow
30-79099 \$59.95



Union Pacific Operating Rotary Snow Plow
30-79098 \$59.95

**SEE THESE CARS IN
ACTION AT
WWW.MTHTRAINS.COM**



New Haven Operating Rotary Snow Plow
30-79096 \$59.95

FEATURES

- Metal Wheels and Axles
- Die-Cast 4-Wheel Trucks
- Operating Die-Cast Metal Couplers
- Colorful, Attractive Paint Schemes
- Decorative Brake Wheels
- Fast-Angle Wheel Sets
- Needle-Point Axles
- Operating Interior Lighting
- Intricately Detailed Durable ABS Body

Operating Signal Man Car

- Waving Signal Man w/Lighted Lantern
- Unit Measures: 11 5/8" x 2 1/2" x 3 3/16"
- Operates On O-31 Curves

Operating Rotary Snow Plow:

- Motorized Spinning Rotary Blade
- Unit Measures: 12" x 2 3/8" x 3 3/4"
- Operates On O-27 Curves



Did You Know?

The IRT Division of the New York subway was the first built, and its narrower tunnels require smaller cars than the BMT and IND Divisions.





Metropolitan LO-V 4-Car Subway Set
30-2447-1 w/Proto-Sound® 2.0 \$399.95

NEW!

Metropolitan LO-V 4-Car Subway Set
30-2447-0 Loco-Sound® \$299.95

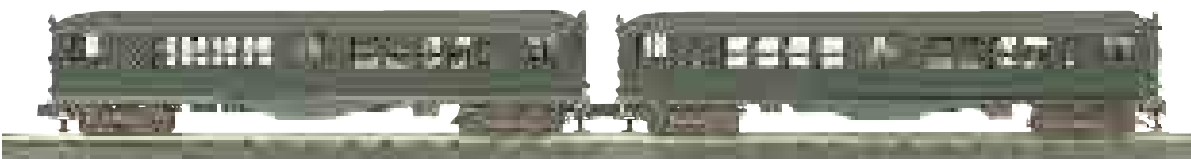

Metropolitan LO-V 2-Car Subway Add-on Set
30-2447-3 (Non-Powered) \$119.95



Metropolitan LO-V 4-Car Subway Set
30-2448-1 w/Proto-Sound® 2.0 \$399.95

NEW!

Metropolitan LO-V 4-Car Subway Set
30-2448-0 Loco-Sound® \$299.95

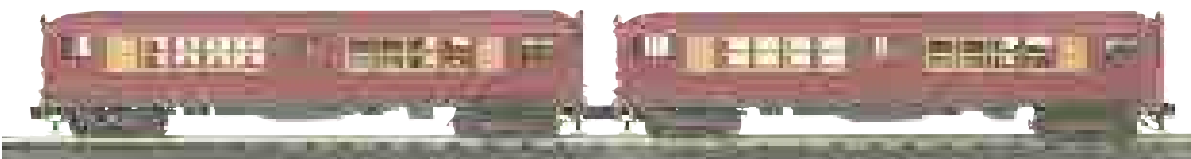

Metropolitan LO-V 2-Car Subway Add-on Set
30-2448-3 (Non-Powered) \$119.95



NEW! Metropolitan Transportation Authority - World's Fair R-12 2-Car Subway Add-On Set
30-2372-3 (Non Powered Set) \$119.95

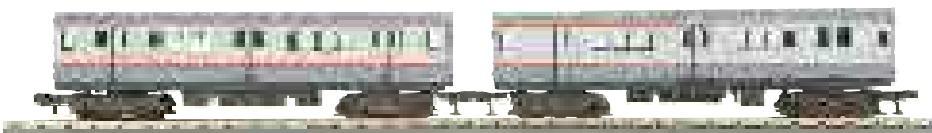

NEW! Metropolitan Transportation Authority - World's Fair R-12 2-Car Subway Add-On Set
30-2373-3 (Non Powered Set) \$119.95

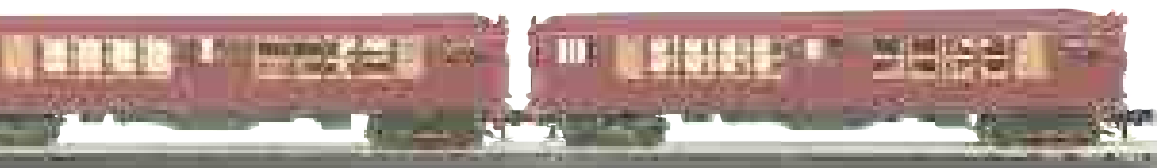

As the IRT (Interborough Rapid Transit) subway expanded in New York City, the need for additional equipment prompted the ordering of 600 low voltage type motor cars. One hundred of these cars came from Pullman in 1916 and 1917, while the remaining 100 were purchased from American Car and Foundry in 1924. An additional 510 non-powered trailer cars entered service between 1916 and 1922. Typical of subway equipment of their day, the steel-sided cars featured rattan seating and rather dim overhead lighting.

The LO-V cars, as the low voltage equipment came to be known, used a low voltage controller, or throttle, to control the high voltage that actually powered the car. This marked a dramatic improvement in safety for the motorman, who in previous HI-V cars had his hand on a controller directly connected to 600 volts of direct current on the third rail. The LO-V cars incorporated a master controller powered by a 32-volt battery, enabling the motorman to control the 600 volts passing through the DC group switches located under the car without fear of electrocution. The LO-V cars served for nearly four decades before being replaced by new cars with plush seating and bright fluorescent lighting.

FEATURES

- Directionally Controlled Headlights
- Intricately Detailed ABS Bodies
- Metal Wheels and Axles
- (2) Remotely Controlled Proto-Couplers™
- Authentic Paint Scheme
- Operates On O-31 Track
- All Metal Wheels and Gears
- Illuminated Number Boards
- (2) Precision Flywheel Equipped Motors In Powered Unit
- Metal Chassis
- Die-Cast Truck Sides
- Lighted Interior
- Proto-Sound® 2.0 With The Digital Command System Featuring: Station Stop Proto-Effects
- Unit Measures: 14 5/8" x 2 1/4" x 3 1/8"

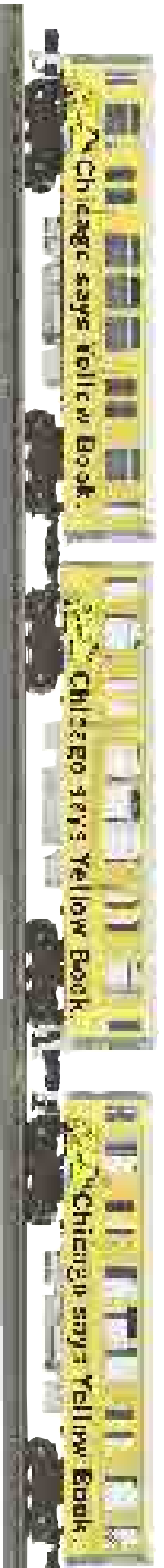

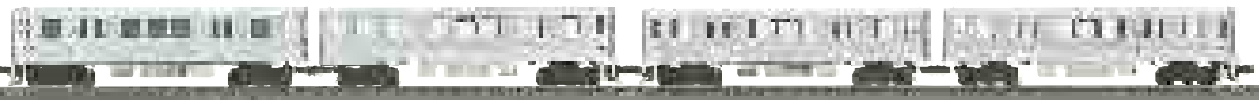

Chicago 4-Car 3200 Series Subway Set
30-2477-1 w/Proto-Sound® 2.0 \$399.95
Chicago 4-Car 3200 Series Subway Set
30-2477-0 Loco-Sound® \$299.95

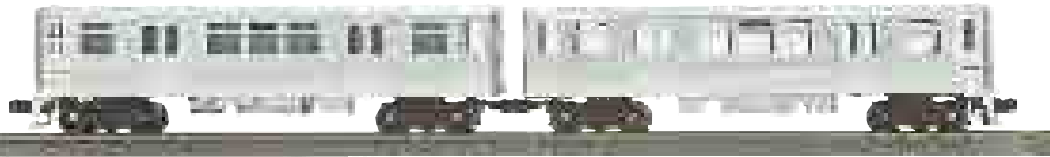

Chicago 2-Car 3200 Series Subway Add-on Set
30-2477-3 (Non-Powered) \$119.95



Chicago Yellow Book 4-Car 3200 Series Subway Set
30-2480-1 w/Proto-Sound® 2.0 \$399.95
Chicago Yellow Book 4-Car 3200 Series Subway Set
30-2480-0 Loco-Sound® \$299.95

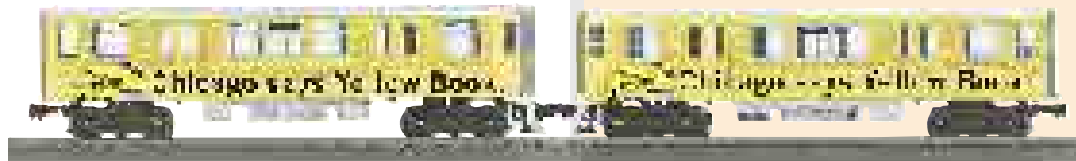

Chicago Yellow Book 2-Car 3200 Series Subway Add-On Set
30-2480-3 (Non-Powered) \$119.95

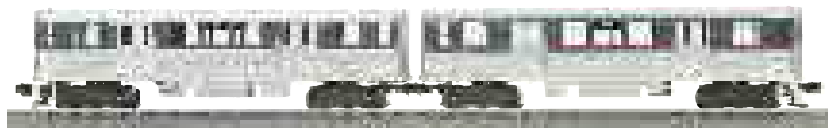

Chicago 2-Car 3200 Series Subway Add-On Set
30-2175-3 (Non-Powered) \$119.95



Closely resembling the 1970 vintage Boeing built 2400 series cars, the CTA 3200 Series subway car first began appearing on Chicago's famed "L" in early 1993. Produced by the Morrison Knudsen Corporation (their first order for new transit cars) the consists have been in use throughout the CTA system.

The design and performance characteristics of the new 3200 series cars are a far leap over previous subway type passenger equipment. Utilizing state-of-the-art microprocessor propulsion control and inverter auxiliary power supply equipment, the cars can be easily retrofitted from 3rd rail pickups to overhead pantographs. A unique operator's compartment provides multi-purpose operator/conductor/ passenger seating capabilities.

Adding the unique look and style of a modern subway consist to your layout has never been easier. Choose from models equipped with or without Proto-Sound® 2.0 and receive all of the standard features found below.

FEATURES

- Directionally Controlled Headlights
- Intricately Detailed ABS Bodies
- Metal Wheels, Axles and Gears
- Die-Cast Truck Sides & Pilots
- (2) Remotely Controlled Proto-Couplers®
- Authentic Paint Scheme
- (2) Precision Flywheel Equipped Motors
- Locomotive Speed Control
- Lighted Cab Interiors
- Illuminated Number Boards
- Each Car Measures 13 1/2" x 2 1/2" x 3 3/8"
- Operates On O-31 Curves

RailKing Passenger Cars are available in popular 60' style bodies that are sure to match whatever era you model. Configured in 4-car, 2-car and single-car configurations, each prototype features car interior detail, overhead interior lighting, end-of-car diaphragms and intricate under-car detail. All configurations are mounted atop die-cast metal 4 or 6-wheel trucks with operating metal couplers, metal wheels and metal axles.

In 2005, choose from heavyweight madison or lightweight streamlined models - each an excellent complement for RailKing steam and diesel locomotives featured earlier in the catalog. Designed to bring authenticity and smooth performing operation to any O Gauge layout, modelers will find no finer O Gauge value than RailKing Passenger Cars.



Pennsylvania 2-Car 60' Madison Combo/Diner Set
30-6986 \$99.95

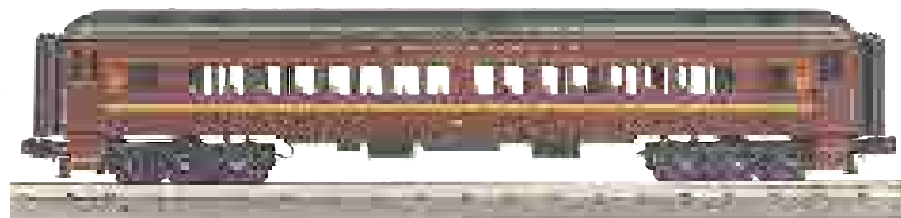

Pennsylvania 60' Madison Coach Car
30-6987 \$49.95



Pennsylvania 4-Car 60' Madison Passenger Set
30-6985 \$199.95

FEATURES

- Durable ABS Intricately Detailed Bodies
- Metal Wheels and Axles
- Overhead Interior Lighting
- Operating Die-Cast Metal Couplers
- Colorful, Attractive Paint Schemes
- End-of-Car Diaphragms
- Fast-Angle Wheel Sets
- Needle-Point Axles
- Detailed Car Interiors
- Die-Cast 6-Wheel Trucks
- Operates On O-31 Curves

4-Car Set:

(1) Baggage, (2) Coaches, (1) Observation.
Unit Measures: 68 3/4" x 2 5/8" x 3 5/16"

2-Car Set:

(1) Combine, (1) Diner.
Unit Measures: 34 6/16" x 2 5/8" x 3 5/16"

Coach Car:

Unit Measures: 16 11/16" x 2 5/8" x 4 5/16"



Jersey Central 4-Car 60' Madison Passenger Set
30-6991 \$199.95

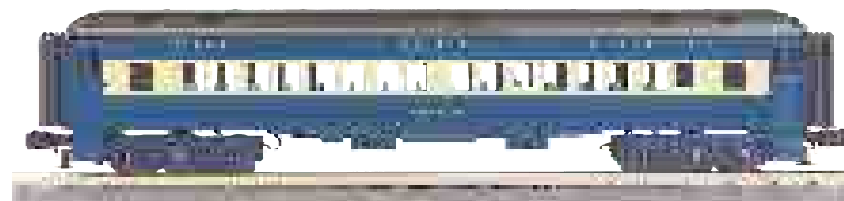

Jersey Central 60' Madison Coach Car
30-6993 \$49.95



Jersey Central 2-Car 60' Madison Combo/Diner Set
30-6992 \$99.95



Milwaukee Road 4-Car 60' Madison Passenger Set
30-6979 \$199.95



Milwaukee Road 60' Madison Coach Car
30-6981 \$49.95



Milwaukee Road 2-Car 60' Madison Combo/Diner Set
30-6980 \$99.95



New York Central 2-Car 60' Madison Combo/Diner Set
30-6983 \$99.95



New York Central 60' Madison Coach Car
30-6984 \$49.95



New York Central 4-Car 60' Madison Passenger Set
30-6982 \$199.95



Southern Pacific O-27 3-Car Streamlined Passenger Set
30-4039S \$119.95



Santa Fe 4-Car 60' Streamlined ABS Passenger Set
30-67174 \$199.95



Santa Fe 2-Car 60' Streamlined ABS Sleeper/Diner
30-67175 \$99.95

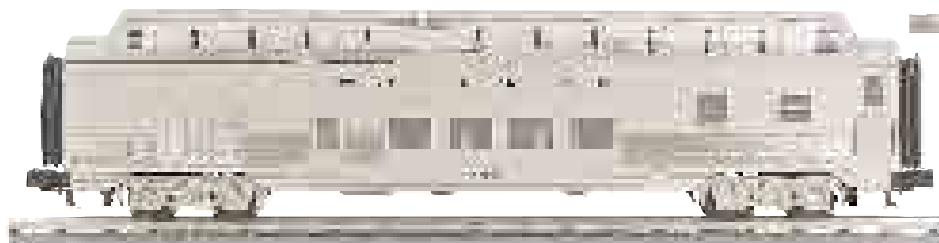

Santa Fe 60' Streamlined ABS Full-Length Vista Dome Car
30-67177 \$54.95

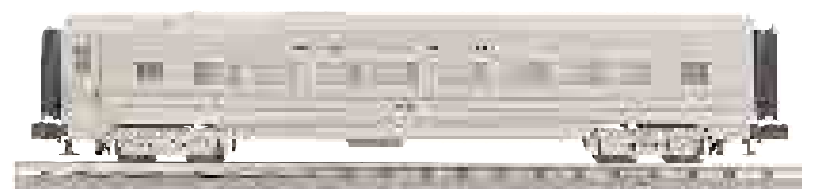

Santa Fe 60' Streamlined ABS Coach Car
30-67176 \$49.95

RailKing Passenger Cars are available in the popular 60' Streamlined and Madison style bodies. Configured in 4-car, 2-car and single-car configurations, each type features car interior detail, overhead interior lighting, end-of-car diaphragms and intricate under-car detail. All configurations are mounted atop die-cast metal 4 or 6-wheel trucks with operating metal couplers, metal wheels and metal axles.

Designed to bring authenticity and smooth performing operation to any O Gauge layout, modelers will find no finer O Gauge value than RailKing Passenger Cars.



Florida East Coast 4-Car 60' Streamlined ABS Passenger Set
30-67210 \$199.95



Florida East Coast 2-Car 60' Streamlined ABS Sleeper/Diner
30-67211 \$99.95

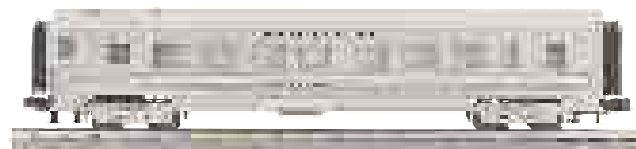

Florida East Coast 60' Streamlined ABS Coach Car
30-67212 \$49.95



Florida East Coast 60' Streamlined ABS Full-Length Vista Dome Car
30-67213 \$54.95



Denver Rio Grande 4-Car 60' Streamlined ABS Passenger Set
30-67166 \$199.95



Denver Rio Grande 2-Car 60' Streamlined ABS Sleeper/Diner
30-67167 \$99.95

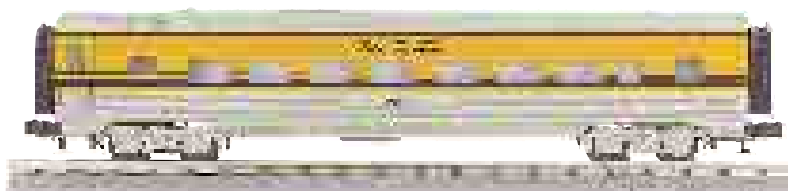

Denver Rio Grande 60' Streamlined ABS Coach Car
30-67168 \$49.95



Denver Rio Grande 60' Streamlined ABS Full-Length Vista Dome Car
30-67169 \$54.95

FEATURES

- Durable ABS Intricately Detailed Bodies
- Metal Wheels and Axles
- Overhead Interior Lighting
- Operating Die-Cast Metal Couplers
- Colorful, Attractive Paint Schemes
- End-of-Car Diaphragms
- Fast-Angle Wheel Sets
- Needle-Point Axles
- Detailed Car Interiors
- Die-Cast 6-Wheel Trucks
- Operates On O-31 Curves

4-Car Set:

(1) Baggage, (2) Coaches, (1) Observation.

Unit Measures: 68 3/4" x 2 5/8" x 3 5/16"

2-Car Set:

(1) Combine, (1) Diner.

Unit Measures: 34 6/16" x 2 5/8" x 3 5/16"

Coach Car:

Unit Measures: 16 11/16" x 2 5/8" x 4 5/16"

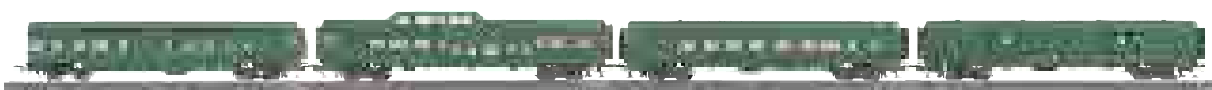

Southern 4-Car 60' Streamlined ABS Passenger Set
30-67178 \$199.95



Southern 60' Streamlined ABS Full-Length Vista Dome Car
30-67181 \$54.95



Southern 2-Car 60' Streamlined ABS Sleeper/Diner
30-67179 \$99.95



Southern 60' Streamlined ABS Coach Car
30-67180 \$49.95



Lehigh Valley 60' Streamlined ABS Full-Length Vista Dome Car
30-67173 \$54.95



Lehigh Valley 4-Car 60' Streamlined ABS Passenger Set
30-67170 \$199.95

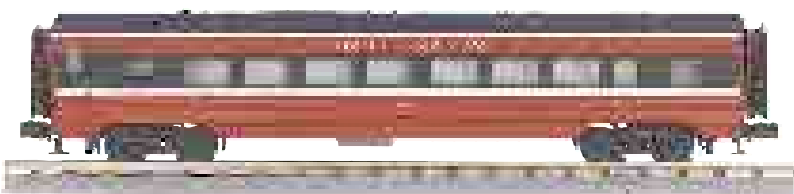

Lehigh Valley 60' Streamlined ABS Coach Car
30-67172 \$49.95



Lehigh Valley 2-Car 60' Streamlined ABS Sleeper/Diner
30-67171 \$99.95



Burlington 60' Streamlined ABS Coach Car
30-67184 \$49.95



Burlington 60' Streamlined ABS Full-Length Vista Dome Car
30-67185 \$54.95



Burlington 2-Car 60' Streamlined ABS Sleeper/Diner
30-67183 \$99.95

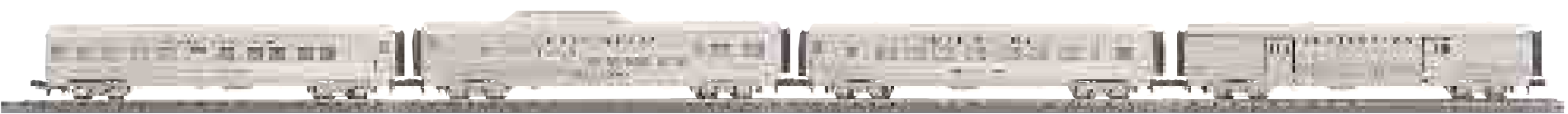

Burlington 4-Car 60' Streamlined ABS Passenger Set
30-67182 \$199.95



Seaboard 4-Car 60' Streamlined ABS Passenger Set
30-67206 \$199.95

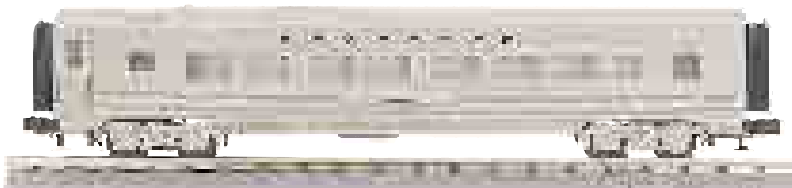

Seaboard 60' Streamlined ABS Coach Car
30-67208 \$49.95



Seaboard 2-Car 60' Streamlined ABS Sleeper/Diner
30-67207 \$99.95

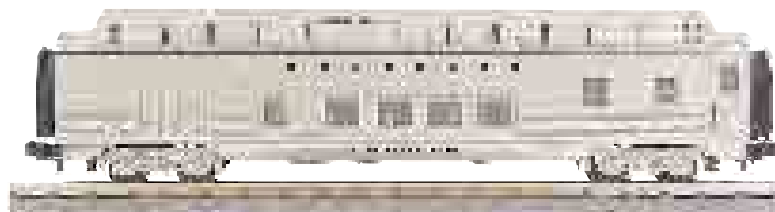

Seaboard 60' Streamlined ABS Full-Length Vista Dome Car
30-67209 \$54.95



Pennsylvania 60' Streamlined ABS Coach Car
30-67204 \$49.95



Pennsylvania 4-Car 60' Streamlined ABS Passenger Set
30-67202 \$199.95



Pennsylvania 2-Car 60' Streamlined ABS Sleeper/Diner
30-67203 \$99.95

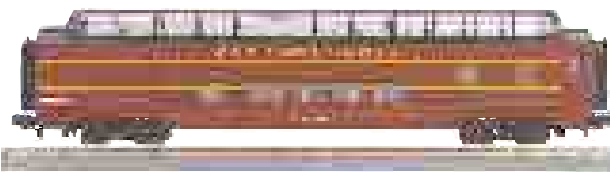

Pennsylvania 60' Streamlined ABS Full-Length Vista Dome Car
30-67205 \$54.95

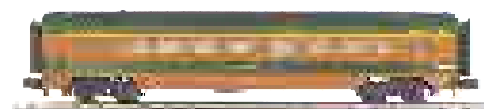

Great Northern 60' Streamlined ABS Coach Car
30-67192 \$49.95



Great Northern 60' Streamlined ABS Full-Length Vista Dome Car
30-67193 \$54.95



Great Northern 2-Car 60' Streamlined ABS Sleeper/Diner
30-67191 \$99.95



Great Northern 4-Car 60' Streamlined ABS Passenger Set
30-67190 \$199.95



Milwaukee Road 4-Car 60' Streamlined ABS Passenger Set
30-67194 \$199.95

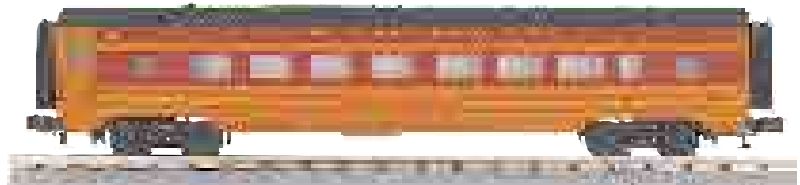

Milwaukee Road 60' Streamlined ABS Coach Car
30-67196 \$49.95



Milwaukee Road 2-Car 60' Streamlined ABS Sleeper/Diner
30-67195 \$99.95



Milwaukee Road 60' Streamlined ABS Full-Length Vista Dome Car
30-67197 \$54.95



Canadian Pacific 60' Streamlined ABS Coach Car
30-67188 \$49.95



Canadian Pacific 4-Car 60' Streamlined ABS Passenger Set
30-67186 \$199.95



Canadian Pacific 2-Car 60' Streamlined ABS Sleeper/Diner
30-67187 \$99.95



Canadian Pacific 60' Streamlined ABS Full-Length Vista Dome Car
30-67189 \$54.95



New Haven 60' Streamlined ABS Coach Car
30-67200 \$49.95

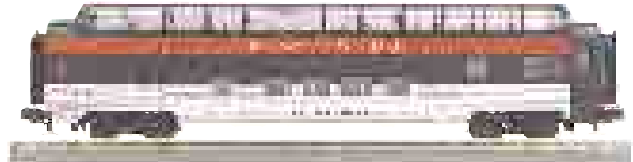

New Haven 60' Streamlined ABS Full-Length Vista Dome Car
30-67201 \$54.95



New Haven 2-Car 60' Streamlined ABS Sleeper/Diner
30-67199 \$99.95



New Haven 4-Car 60' Streamlined ABS Passenger Set
30-67198 \$199.95



Steam Locomotives62



Diesel & Electric Locomotives82

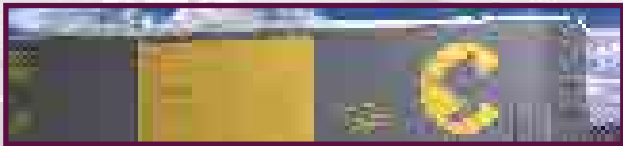

Freight Cars96

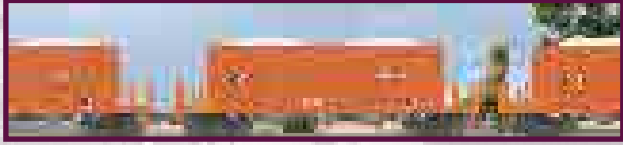

Freight Car Sets126

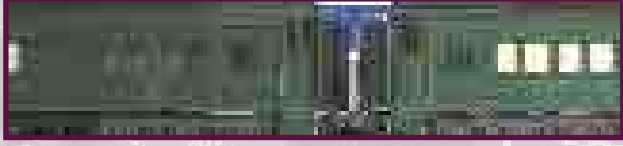

Passenger Sets132



Operators long desiring to run locomotives that are more prototypical in appearance on their 3-rail railroad can now choose an M.T.H. Premier Line steam locomotive with scale flanged wheels and configure it for 3-rail operation in just minutes. Every M.T.H. Premier Line steam locomotive in the 2005 product line is available with Hi-Rail or Scale Wheels and include the all-new Proto-Scale 3-2™ feature.

Locomotives equipped with Proto-Scale 3-2™ can be operated on 3 or 2-rail track under AC or DC power. A small switch will redirect track power from the center rail pickups to the locomotive's left side drive wheels. Ground will move from all locomotive wheels for 3-rail operation to the right side locomotive wheels on 2-rail track. The center rail pickup rollers will be easily added or removed from the bottom of the locomotive chassis without requiring disassembly of the engine. Total conversion takes less than two minutes and can be accomplished with a screwdriver.

Each Premier Line locomotive equipped with Scale Wheels will be packaged with a set of center rail pickup rollers so that the engine can be quickly converted for 3-rail use.

ADD 2-RAIL REALISM TO YOUR HI-RAIL MODEL RAILROAD



Convert from 3 to 2 rail Operation (or vice versa) in Minutes

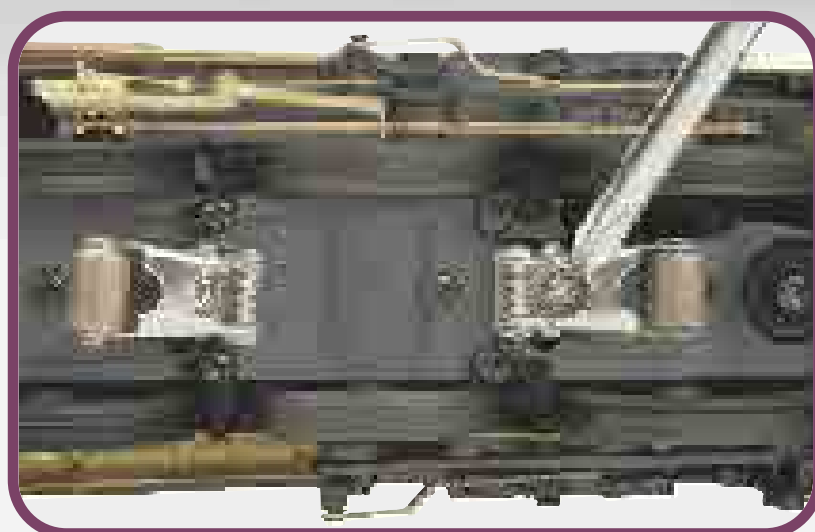

PROTO-SCALE™

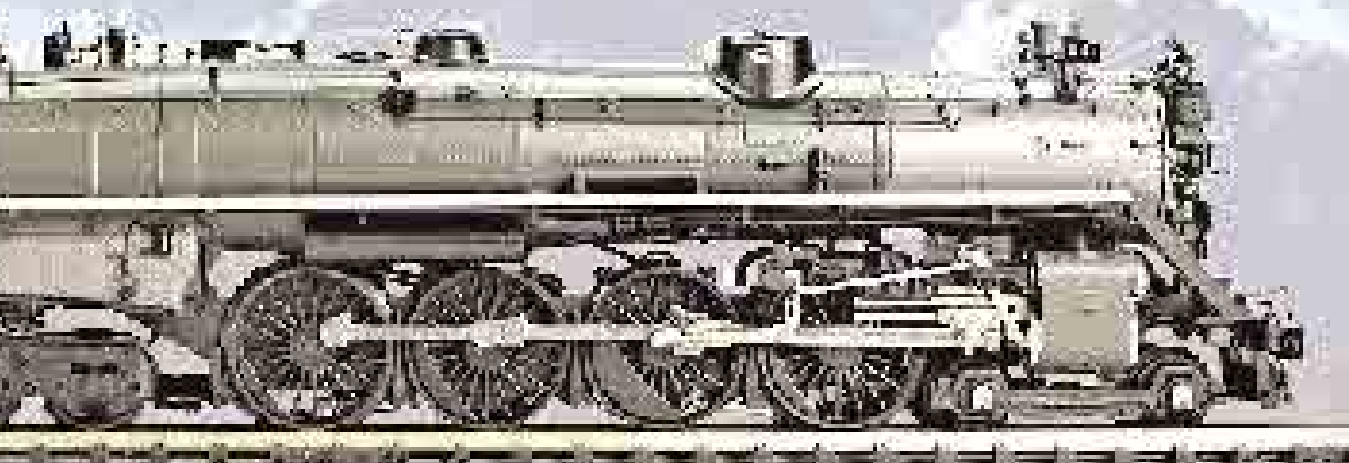

OPERATES ON AC OR DC POWER

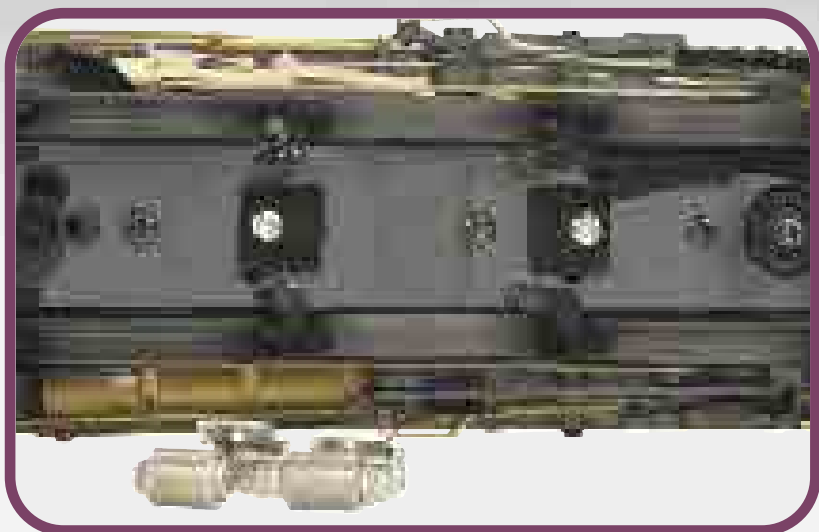

Scale or Hi-Rail Wheels Which Is Right For You?

Hi-Rail Wheels

M.T.H. Premier Line locomotives equipped with Hi-Rail Wheels feature taller flanges, blind center drivers, wider wheels and traction tires. These engines each include the Proto-Scale 3-2™ feature and are designed for operation on any type of 3-rail track system but can be quickly converted for use on 2-Rail track. The taller flanges on the Hi-Rail Wheeled locomotives may contact the track ties on low profile 2-rail track systems.

Scale Wheels

Two-rail Proto-Scale 3-2 locomotives feature narrower scale-width wheels with more-prototypical low flanges. There are no blind (non-flanged) wheels or traction tires on locomotives with scale wheels. These engines can be converted for use on 3-rail track by installing the center rail pickup rollers that are included with each engine. Because flanges are present on all wheels and are low in height, operation on some 3-rail track systems and switches may be compromised. The use of flanges on all wheels will increase the minimum curve requirement of scale-wheeled locomotives, and some uneven operation may be noticeable when traversing 3-rail switches. Engines with scale wheels are also equipped with body-mounted scale couplers that will not mate with standard 3-rail couplers. See the M.T.H. website for specific minimum curve requirements for each Scale Wheeled-equipped locomotive.

Did You Know?

The USRA designs were modern but conservative. They incorporated the best practices of their day, but broke little new ground. After the war, the basic designs were used by railroads across the nation, and many USRA-design engines remained in service to the end of steam.



FEATURES

- Die-Cast Boiler and Tender Body
- 1:48 Scale Proportions
- Die-Cast Metal Chassis
- Authentic Paint Scheme
- Metal Wheels and Axles
- Constant Voltage Headlight
- Die-Cast Truck Sides
- Precision Pittman® Flywheel Equipped Motor
- (2) Remote Controlled Proto-Couplers™
- Engineer and Fireman Figures
- Operating Firebox Glow
- Metal Handrails and Decorative Bell
- Decorative Metal Whistle
- Proto-Scale 3-2™ 3-Rail/2-Rail Conversion Capable
- Operating Marker Lights
- Lighted Cab Interior
- Operating ProtoSmoke™ System
- Operating Tender Back-up Light
- Proto-Sound® 2.0 With The Digital Command System Featuring:- Freight Yard Proto-Effects™
- Unit Measures: 21" x 2 5/8" x 3 11/16"
- Operates On O-42 Curves

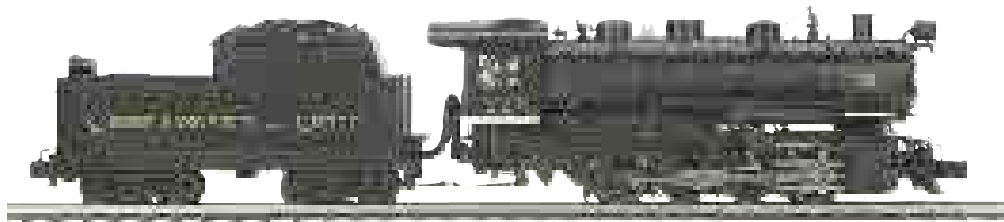

Chesapeake & Ohio - 0-8-0 USRA Steam Engine w/Proto-Sound® 2.0
 20-3147-1 Hi-Rail Wheels \$599.95
 20-3147-2 Scale Wheels \$599.95

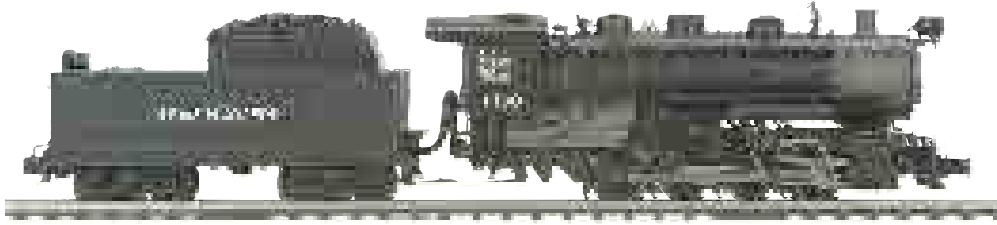

New Haven - 0-8-0 USRA Steam Engine w/Proto-Sound® 2.0
 20-3148-1 Hi-Rail Wheels \$599.95
 20-3148-2 Scale Wheels \$599.95

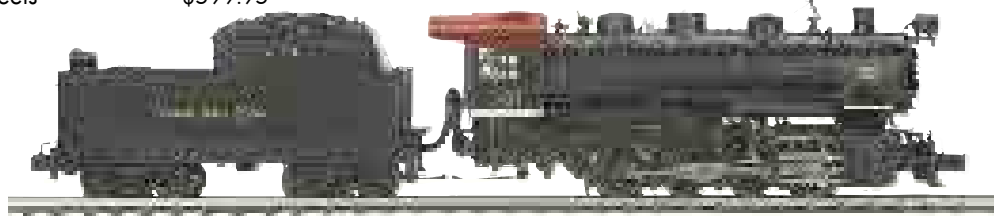

Nickel Plate Road - 0-8-0 USRA Steam Engine w/Proto-Sound® 2.0
 20-3149-1 Hi-Rail Wheels \$599.95
 20-3149-2 Scale Wheels \$599.95

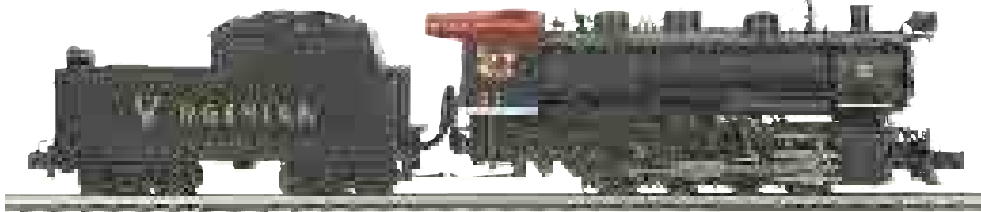

Virginian - 0-8-0 USRA Steam Engine w/Proto-Sound® 2.0
 20-3150-1 Hi-Rail Wheels \$599.95
 20-3150-2 Scale Wheels \$599.95

Union Pacific - 0-8-0 USRA Steam Engine w/Proto-Sound® 2.0
 20-3151-1 Hi-Rail Wheels \$599.95
 20-3151-2 Scale Wheels \$599.95



During World War I, Uncle Sam nationalized the railroads when they proved unequal to the task of moving massive amounts of men and material for the war effort. The agency that ran the trains was the United States Railroad Administration, or USRA, and one of its chief accomplishments was the creation of 12 steam engine designs that lasted for decades. One of the most popular was an 0-8-0 switcher that eventually appeared on 52 railroads.

This 0-8-0 marks the third USRA design to appear in the M.T.H. Premier lineup and the first for a switch engine. Built to 1/48 scale proportions, the locomotive includes the intricate detail and quality die-casting that have made Premier Line steam locomotives the industry leader.

The tooling for the tender has been designed so railroad-specific coal bunkers can be installed on the tender body, providing an added level of realism. More importantly, each 0-8-0 is outfitted with the incredible sounds and features of Proto-Sound® 2.0, including patented locomotive speed control and synchronized puffing smoke.

Each road name is available as a Hi-Rail or Scale Wheel model. Both versions feature Proto-Scale 3-2™, the new M.T.H. feature that allows an operator to configure either model for use on 2-rail or 3-rail track.

Premier Steam Engine

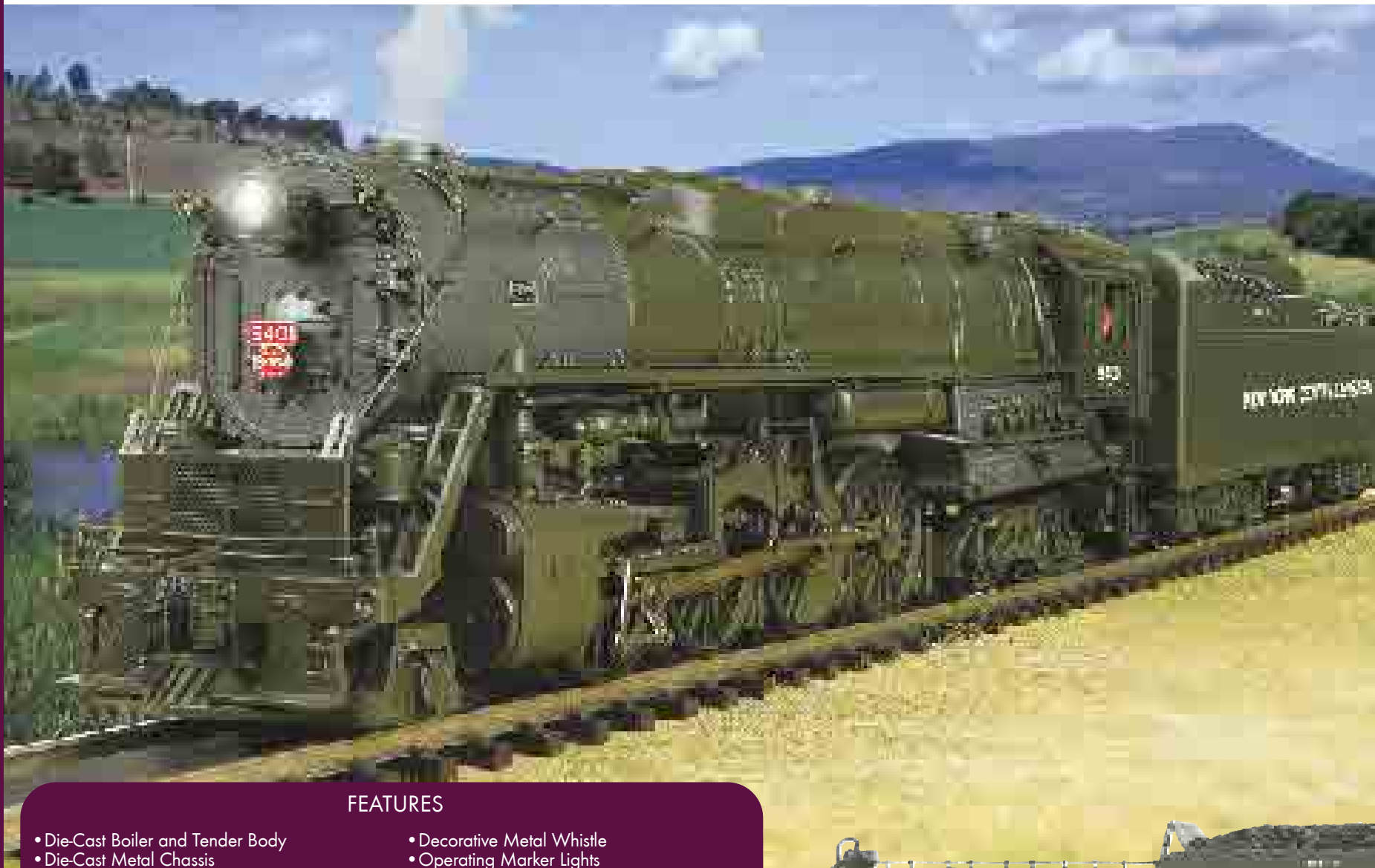

FEATURES

- Die-Cast Boiler and Tender Body
- Die-Cast Metal Chassis
- Authentic Paint Scheme
- Metal Wheels and Axles
- Constant Voltage Headlight
- Die-Cast Truck Sides
- Precision Pittman® Flywheel Equipped Motor
- Remote Controlled Proto-Coupler™
- Engineer and Fireman Figures
- Operating Firebox Glow
- Metal Handrails and Decorative Bell
- Decorative Metal Whistle
- Operating Marker Lights
- Lighted Cab Interior
- Synchronized Puffing ProtoSmoke™ System
- Operating Tender Back-up Light
- Locomotive Speed Control
- Proto-Sound® 2.0 With The Digital Command System Featuring:- Freight Yard Proto-Effects™
- Unit Measures: 27 1/2" x 2 3/4" x 3 7/8"
- Operates On O-54 Curves



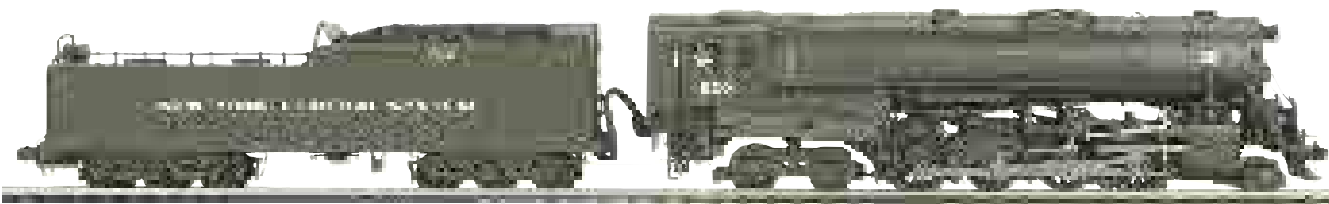

New York Central - 2-8-4 A-2 Berkshire Steam Engine
 20-3128-1 Proto-Sound® 2.0 \$999.95

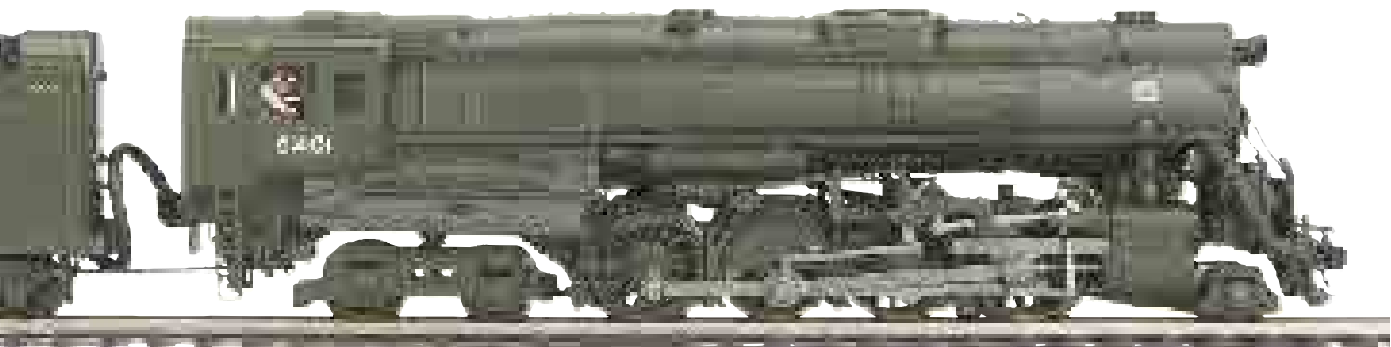

By the late 1940's, the New York Central railroad had ordered or already owned 600 diesel locomotives. The railroad's future was set and it would seem that it didn't include a part for steam locomotives. So it is with raised eyebrow that historians look back on the railroad's decision to create the A-2 Berkshire steam locomotive in 1947.

Perhaps the decision was a last grasp to continue the steam era before dieselization overran motive power, or more cynically, an overture to coal interests that may have guided the New York Central's motive power department's decision making. Regardless, the creation of the 2-8-4 A-2 three years after the S-1 Niagara failed to stem the tide of dieselization, earned it the distinction of being the last steam engine class to be built for the NYC or its subsidiaries.

Like the S-1, the A-2 sports similar lines and appearances to its earlier cousin. These huge locomotives relied on massive boiler capacity rather than efficiency gadgets seen on other late steam era locomotives. Consequently they were not all that appreciated by their crews during their short eight year history.

The A-2 marks the fifth prototypical recreation of a classic New York Central steam locomotive in the M.T.H. Premier Line. Like the three Hudson and one Niagara models that came before the A-2, this all-new die-cast locomotive is built to scale proportions and features the most realistic and easy-to-use operating features found on any O Gauge locomotive available today.

Did You Know?

The A-2 Berkshire was the last mainline steam locomotive ordered by the NYC and saw service in Indianapolis, Cincinnati and southeastern Pennsylvania.



FEATURES

- Die-Cast Boiler and Tender Body
- 1:48 Scale Proportions
- Die-Cast Metal Chassis
- Authentic Paint Scheme
- Metal Wheels and Axles
- Constant Voltage Headlight
- Die-Cast Truck Sides
- Remote Controlled Proto-Coupler™
- Engineer and Fireman Figures
- Operating Firebox Glow
- Metal Handrails and Decorative Bell
- Decorative Metal Whistle
- Operating Marker Lights
- Proto-Scale 3-2" 3-Rail/2-Rail Conversion Capable
- Lighted Cab Interior
- Operating ProtoSmoke™ System
- Operating Tender Back-up Light
- Precision Flywheel Equipped Motor
- Proto-Sound® 2.0 With The Digital Command System Featuring:- Freight Yard Proto-Effects™
- Unit Measures: 16 3/4" x 3 3/4" x 2 1/2"
- Operates On O-42 Curves



Long Island - 4-4-0 Steam Engine w/Proto-Sound® 2.0
 20-3153-1 Hi-Rail Wheels \$699.95
 20-3153-2 Scale Wheels \$699.95



NEW!

New York Central - 4-4-0 Steam Engine w/Proto-Sound® 2.0
 20-3154-1 Hi-Rail Wheels \$699.95
 20-3154-2 Scale Wheels \$699.95



NEW!

Baltimore & Ohio - 4-4-0 Steam Engine w/Proto-Sound® 2.0
 20-3155-1 Hi-Rail Wheels \$699.95
 20-3155-2 Scale Wheels \$699.95



NEW!

Pennsylvania - 4-4-0 Steam Engine w/Proto-Sound® 2.0
 20-3156-1 Hi-Rail Wheels \$699.95
 20-3156-2 Scale Wheels \$699.95

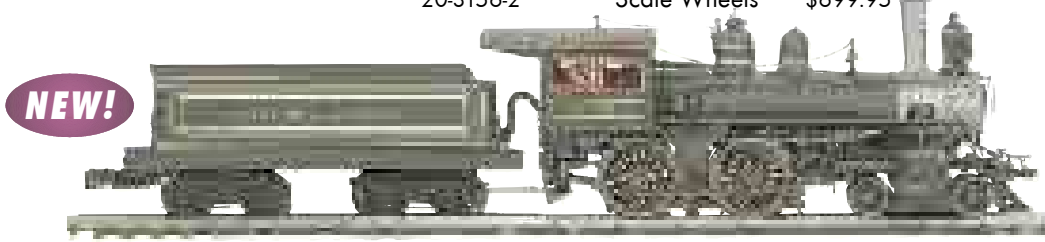

NEW!

Strasburg - 4-4-0 Steam Engine w/Proto-Sound® 2.0
 20-3172-1 Hi-Rail Wheels \$699.95
 20-3172-2 Scale Wheels \$699.95



NEW!

The 4-4-0 was the passenger engine of the last half of the nineteenth century. Subject of dozens of Currier & Ives lithographs, the 4-4-0 carried the nation westward, touched cowcatchers at the Golden Spike in 1869, transported millions of Americans out of their home towns for the first time, and hauled a good deal of freight as well. Often beautifully colored and pinstriped, the 4-4-0 steam engine became a symbol of U.S. railroading - so much so that this wheel arrangement was named the "American."

The Pennsylvania Railroad, never one to do things in a small way, built or bought over 1500 Americans between 1849 and 1910. For five decades, engines of this wheel arrangement were the road's principal passenger power. Some remained in local service as late as World War II.

Designed in Pennsy's Altoona shops in 1881, the class K Americans, later reclassified D6, represented an elegant and successful step in the evolution of Pennsy motive power. This new 4-4-0 design featured larger cylinders, higher boiler pressure, and bigger drivers (78") than its predecessors. The D6 also introduced three features not seen before on Pennsylvania engines: power reverse gear, Alligator crossheads with two-bar guides, and sand boxes in the fenders over the drivers, rather than a sand dome. The characteristic Pennsy squared-off Belpaire firebox, however, would not make its appearance until just after the 19th and last D6 was outshopped by Altoona.

Following on the heels of the Pennsylvania H3 2-8-0 Consolidation announced in 2004, the Premier D6 American makes its debut in 2005. The American is fully outfitted with Proto-Sound® 2.0 and is available in both Hi-Rail or Scale Wheel versions. Each is equipped with Proto-Scale 3-2™, which allows the user to quickly convert either version for operation on 2- or 3-rail track.



Did You Know?

Built mainly in Alco's Schenectady shops in the late 1920s and early 1930s, the NYC Hudsons were part of the "super-power" era of steam technology that began with Lima's A1 Berkshire in 1924. Super power engines were the external combustion engine refined to its finest form, with technological advances such as bigger fireboxes supported by 4-wheel trailing trucks; higher pressure, more efficient boilers; superheaters to increase the heat of the steam so it could do more work; and larger drivers for speed and power (79" on the Hudsons).

FEATURES

- Die-Cast Boiler and Tender Body
- Die-Cast Metal Chassis
- Authentic Paint Scheme
- Metal Wheels and Axles
- Constant Voltage Headlight
- Die-Cast Truck Sides
- Precision Pittman® Flywheel Equipped Motor
- Remote Controlled Proto-Coupler™
- Engineer and Fireman Figures
- Operating Firebox Glow
- Metal Handrails and Decorative Bell
- Decorative Metal Whistle
- Operating Marker Lights
- Proto-Scale 3-2™ 3-Rail/2-Rail Conversion Capable
- Lighted Cab Interior
- Operating Tender Back-up Light
- Locomotive Speed Control
- Synchronized Puffing ProtoSmoke™ System
- Proto-Sound® 2.0 With The Digital Command System Featuring:- Passenger Station Proto-Effects™
- Unit Measures: 27" x 2 1/2" x 3 7/8"
- Operates On O-42 Curves

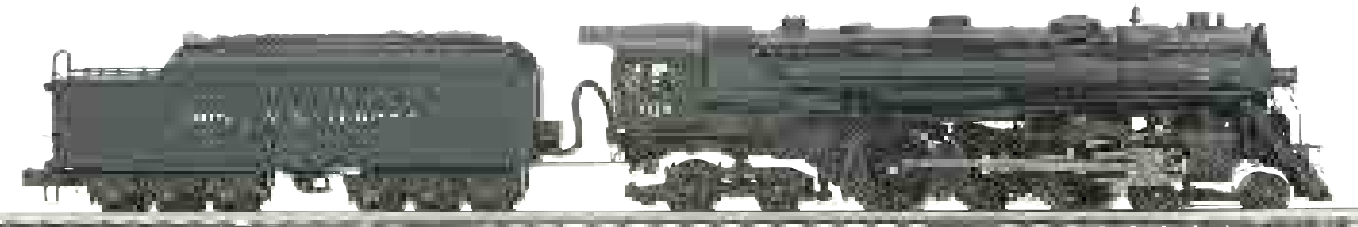

Boston & Albany - 4-6-4 J-1e Hudson Steam Engine w/Proto-Sound® 2.0
 20-3157-1 Hi-Rail Wheels \$999.95
 20-3157-2 Scale Wheels \$999.95

**ADD A SET OF
 PASSENGER
 CARS
 SEE PAGE 133**

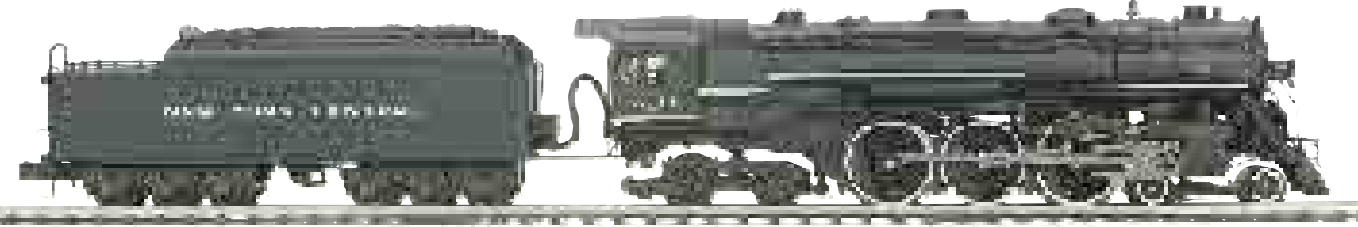

New York Central - 4-6-4 J-1e Hudson Steam Engine w/Proto-Sound® 2.0
 20-3158-1 Hi-Rail Wheels \$999.95
 20-3158-2 Scale Wheels \$999.95

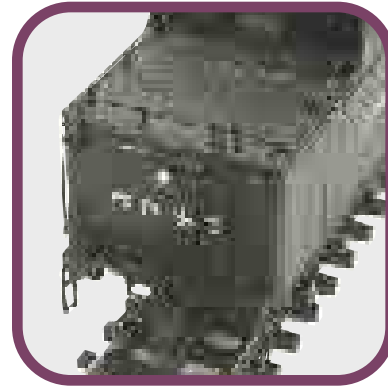
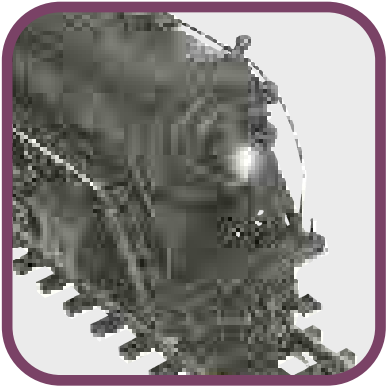

In *Thoroughbreds*, Alvin Stauffer and Edward May's definitive book on the New York Central Hudsons, Al summarizes the attraction of this engine in a few perhaps-biased but nonetheless eloquent words: "The Hudsons had it all: looks, performance, and timing. ... [The] forte of all Hudsons was power at speed.... That [the NYC Hudson] was the first of her wheel arrangement in the United States matters not nearly as much as what she hauled and how she hauled it. The Hudsons were designed to haul the Great Steel Fleet on the Water Level Route [the NYC's raceway from New York to Chicago, home of the 20th Century Limited and the Empire State Express, and the bane of rival Pennsylvania Railroad, whose route lay over the Allegheny Mountains]. The Hudsons were a New York Central phenomenon. They were a special machine for that special road. They were synonymous with the best. They were the best."

Thanks to Joshua Lionel Cowen, the Hudson also holds a special place in the history of 3-rail O gauge. The 700E scale Hudson, manufactured from 1937 to 1942, set a standard of detail for 3-rail engines that was unmatched for nearly 50 years, until M.T.H. began the trend toward scale detailing that continues today.

Like Lionel in 1937, we believe our model of this engine exemplifies the best in today's O gauge locomotives. The M.T.H. J1e reappears in the Premier Line in 2005 in splendid dress striping and sporting the power and performance of Proto-Sound® 2.0.

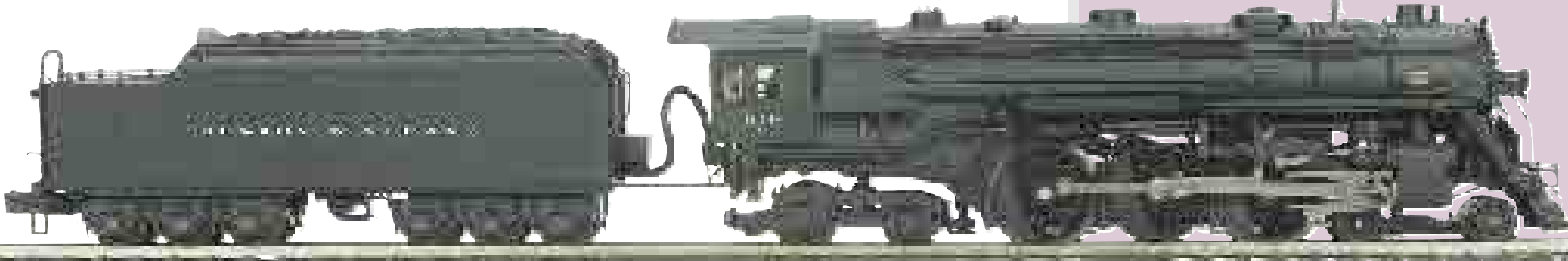



FEATURES

- Die-Cast Boiler and Tender Body
- Die-Cast Metal Chassis
- Authentic Paint Scheme
- Metal Wheels and Axles
- Constant Voltage Headlight
- Die-Cast Truck Sides
- Precision Pittman® Flywheel Equipped Motor
- Remote Controlled Proto-Coupler™
- Engineer and Fireman Figures
- Operating Firebox Glow
- Metal Handrails and Decorative Bell
- Decorative Metal Whistle
- Operating Marker Lights
- Lighted Cab Interior
- Synchronized Puffing ProtoSmoke™ System
- Operating Tender Back-up Light
- Locomotive Speed Control
- 1:48 Scale Proportions
- Proto-Scale 3-2™ 3-Rail/2-Rail Conversion Capable
- Proto-Sound® 2.0 With The Digital Command System Featuring:- Passenger Station Proto-Effects™
- Unit Measures: 27" x 2 5/8" x 4 1/8"
- Operates On O-42 Curves



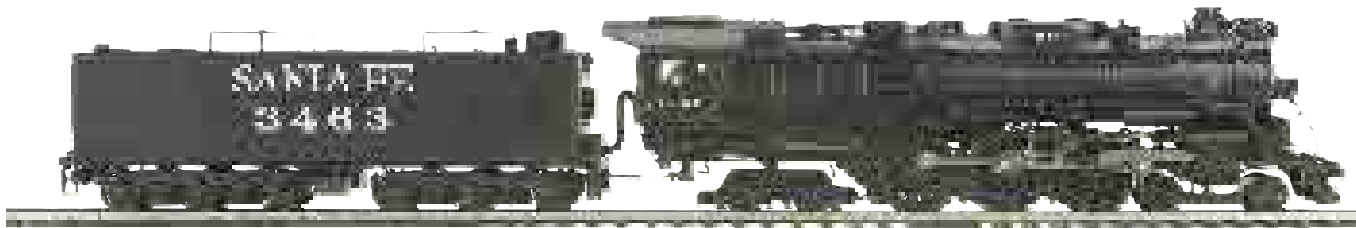

Santa Fe - 4-6-4 Steam Locomotive w/Proto-Sound® 2.0
 20-3135-1 Hi-Rail Wheels \$999.95
 20-3135-2 Scale Wheels \$999.95

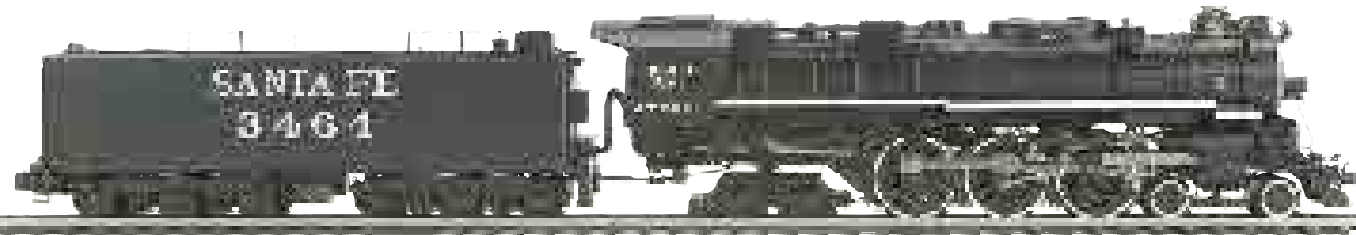

Santa Fe - 4-6-4 Steam Locomotive w/Proto-Sound® 2.0
 20-3144-1 Hi-Rail Wheels \$999.95
 20-3144-2 Scale Wheels \$999.95

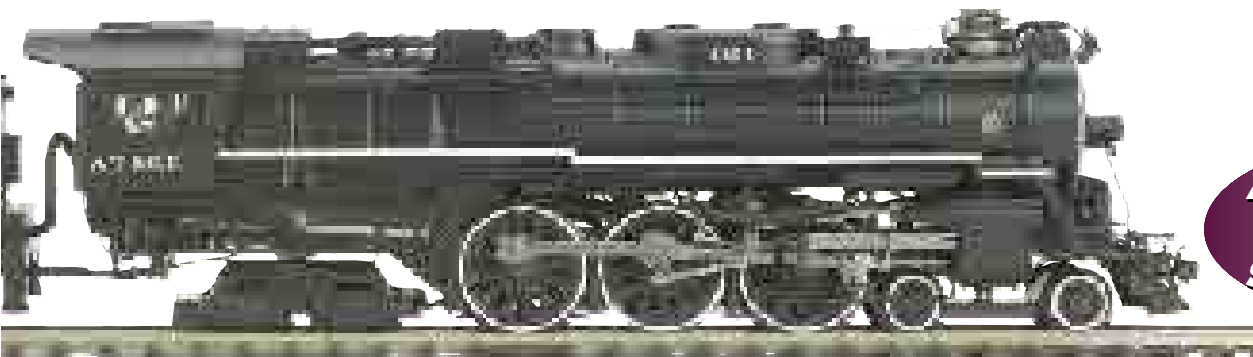
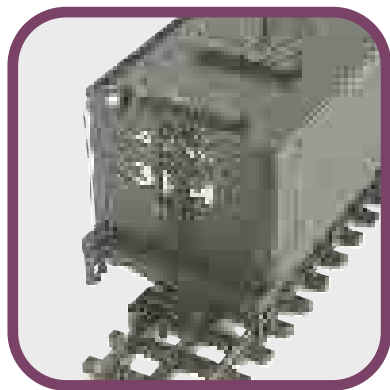

**ADD A SET OF
 PASSENGER
 CARS
 SEE PAGE 133**

Rising passenger volume for the Atchison, Topeka & Santa Fe's 922 miles of main line service between La Junta, Colorado and Chicago resulted in the production of a new class of 4-6-4 Hudson locomotives from the Baldwin Locomotive Works. Six of these Class 3460 oil burning locomotives were delivered in 1938 to the Santa Fe. At the time, the locomotives were the largest 4-6-4 types yet produced and utilized a fuel oil tank built into the water tank inside the tender. Such an arrangement allowed for easy conversion of the locomotive to a coal-burning type.

The Santa Fe, like many railroads in the 1940s flirted with streamlining. Engine No. 3460 was actually delivered to the A.T.S.F. with light steel shrouding and a gloss blue paint scheme that earned the nickname "Blue Goose". M.T.H. released the streamlined version in 2002 and is proud to now offer the unshrouded version of one of the Santa Fe's most important locomotives.

Fully outfitted with the power and performance of Proto-Sound® 2.0, the Class 3460 Hudson, like all Premier steam engines, is equipped with synchronized puffing smoke, Proto-Speed Control™ for incredible slow speed action and the hobby's only Passenger Station Proto-Effects™ which recreate the sound of an engine arriving at a station, complete with arrival and departure announcements, conductor direction and boarding and disembarking sounds.



Did you know?

In the summer of 1956, a motive power shortage led the Pennsy to lease a dozen of the Santa Fe's 5000-series 2-10-4s. The huge oil burners were put to work hauling coal from Columbus to Sandusky, Ohio. Pennsy crews liked them for their easy steaming and good riding qualities.

FEATURES

- Die-Cast Boiler and Tender Body
- 1:48 Scale Proportions
- Die-Cast Metal Chassis
- Authentic Paint Scheme
- Metal Wheels and Axles
- Constant Voltage Headlight
- Die-Cast Truck Sides
- Precision Pittman® Flywheel Equipped Motor
- Remote Controlled Proto-Coupler™
- Engineer and Fireman Figures
- Operating Firebox Glow
- Metal Handrails and Decorative Bell
- Decorative Metal Whistle
- Operating Marker Lights
- Lighted Cab Interior
- Synchronized Puffing ProtoSmoke™ System
- Locomotive Speed Control
- Operating Tender Back-up Light
- Proto-Scale 3-2 3-Rail/2-Rail Conversion Capable
- Available In 2 or 3-Rail Versions
- Proto-Sound 2.0 With The Digital Command System Featuring:- Freight Yard Proto-Effects™
- Unit Measures: 30 1/2" x 4 1/4" x 2 3/4"
- Operates On O-72 Curves





Chesapeake & Ohio - J-1 2-10-4 Steam Engine w/Proto-Sound® 2.0
 20-3159-1 Hi-Rail Wheels \$1099.95
 20-3159-2 Scale Wheels \$1099.95

NEW!



Pennsylvania - J-1 2-10-4 Steam Engine w/Proto-Sound® 2.0
 20-3160-1 Hi-Rail Wheels \$1099.95
 20-3160-2 Scale Wheels \$1099.95

NEW!

NEW!



Pennsylvania (Tuscan Tender Deck and Cab Roof) - J-1 2-10-4 Steam Engine w/Proto-Sound® 2.0
 20-3171-1 Hi-Rail Wheels \$1099.95
 20-3171-2 Scale Wheels \$1099.95

Santa Fe - J-1 2-10-4 Steam Engine w/Proto-Sound® 2.0
 20-3161-1 Hi-Rail Wheels \$1099.95
 20-3161-2 Scale Wheels \$1099.95



The J1 was the Pennsy's War Baby, conceived and born to move freight for World War II. Like most American railroads, the Pennsylvania found itself short of motive power when traffic ramped up for the war. The Pennsy would have preferred to design its own modern steam loco, but the War Production Board declared otherwise. Only existing, proven designs would be authorized for wartime construction. In retrospect, that was probably a good thing, because none of the Pennsy's postwar steam designs came close to the success of the J1.

For its war baby, the Pennsylvania chose a design created twelve years earlier by Lima for the Chesapeake & Ohio. The C&O T1 2-10-4 possessed the key attribute of a modern "super-power" locomotive: power at speed. Home-built in the Juniata shops from 1942 to 1944, the Pennsy's 125 copies, designated classes J1 and J1a, were quickly recognized by Pennsy faithful as among of the best steamers produced in the modern era. They were at home anywhere west of Altoona, pounding up heavy grades or flying along level stretches. Being based on another road's design, they possessed two distinctively un-Pennsy features - a booster engine and a radial-stay rather than Belpaire firebox. However, their builders managed to give the J's a look all their own, with a substantial Pennsy cast pilot, streamlined cab windows, and a single massive dome that served as both sandbox and steam dome. Viewed from trackside at speed, the J's were the epitome of high, wide, and handsome.

For 2005, three legendary 2-10-4 Texas locomotives appear in the M.T.H. Premier lineup: the new Pennsylvania J1 and its C&O T1 predecessor, as well as an upgraded version of the Santa Fe 5000-series Texas last cataloged in 2001. Outfitted with Proto-Sound® 2.0, the 2-10-4s are available in both Hi-Rail or Scale Wheel versions, each equipped with Proto-Scale 3-2™, which allows the user to quickly convert either version for operation on 2- or 3-rail track.



FEATURES

- Die-Cast Boiler and Tender Body
- Die-Cast Metal Chassis
- Authentic Paint Scheme
- Metal Wheels and Axles
- Constant Voltage Headlight
- Die-Cast Truck Sides
- Precision Pittman® Flywheel Equipped Motor
- Remote Controlled Proto-Coupler™
- Engineer and Fireman Figures
- Operating Firebox Glow
- Metal Handrails and Decorative Bell
- Decorative Metal Whistle
- Operating Marker Lights
- Lighted Cab Interior
- Synchronized Puffing ProtoSmoke™ System
- Operating Tender Back-up Light
- Locomotive Speed Control
- 1:48 Scale Proportions
- Proto-Scale 3-2™ 3-Rail/2-Rail Conversion Capable
- Proto-Sound® 2.0 With The Digital Command System Featuring:- Passenger Station Proto-Effects™
- Unit Measures: 26 1/2" x 2 3/4" x 4 1/8"
- Operates On O-54 Curves



NEW!

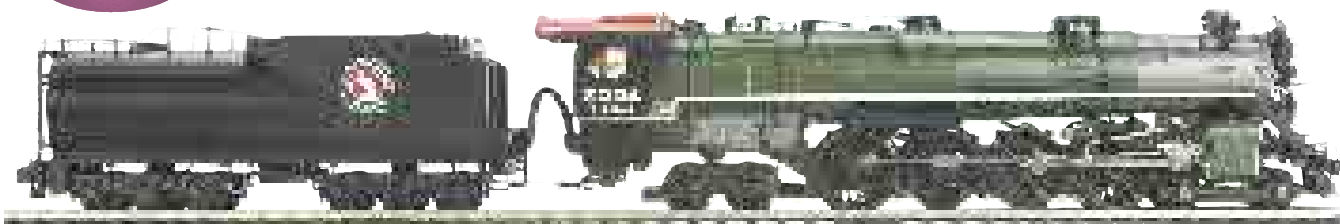

Great Northern - 4-8-4 Steam Locomotive w/Proto-Sound 2.0

20-3145-1	(Cab #2584) Hi-Rail Wheels	\$1199.95
20-3145-2	(Cab #2584) Scale Wheels	\$1199.95
20-3146-1	(Cab #2587) Hi-Rail Wheels	\$1199.95
20-3146-2	(Cab #2587) Scale Wheels	\$1199.95

**ADD A SET OF
PASSENGER
CARS
SEE PAGE 132**



The first 4-8-4 Northern to appear on the Great Northern did so in 1929 after arriving from the Baldwin Locomotive works. Designated Class S, the locomotives were purchased by the Great Northern in two models, S-1 and S-2.

Designated for fast passenger work, the S-2 locomotives utilized a radial stay firebox rather than the Belpaire variety found on the S-1. In addition, larger 80" drivers, the tallest of any Northern model, gave the S-2 fast speed ratings though she carried a reputation of being slippery when pulling a heavy train.

Heading up an all-welded vanderbilt tender, the S-2 sported the classic cascade green livery of the Great Northern along with chrome plated cylinder covers and steam chest heads. The striking appearance made the locomotive the perfect choice for the Oriental Limited and Empire Builder passenger trains until the Northern's retirement in the mid 1950s. No. 2584 remains on display, in her cascade green livery, at the Havre, Montana depot. The Empire Builder train she headed celebrated its 75th Anniversary in 2004 while the engine that made it famous will celebrate hers in 2005.

Outfitted with industry-leading features and performance, the S-2 is available in two cab numbers and is sold in both Hi-Rail and Scale Wheel versions. Both versions include our latest feature, found only in M.T.H. Premier Line locomotives, Proto-Scale 3-2™ which allows the user to configure in minutes either model for use on 2-rail or 3-rail track

4-8-4



Did You Know?

The UP apparently expected to get the remaining six Challengers they had ordered after the war - but the U.S. government, who owned them, stored them in Salt Lake City until striking the deal that sent them to the Clinchfield.

FEATURES

- Die-Cast Boiler and Tender Body
- 1:48 Scale Proportions
- Die-Cast Metal Chassis
- Authentic Paint Scheme
- Metal Wheels and Axles
- Constant Voltage Headlight
- Die-Cast Truck Sides
- Precision Pittman® Flywheel Equipped Motor
- Remote Controlled Proto-Coupler™
- Engineer and Fireman Figures
- Operating Firebox Glow
- Metal Handrails and Decorative Bell
- Decorative Metal Whistle
- Operating Marker Lights
- Lighted Cab Interior
- Operating Tender Back-up Light
- Locomotive Speed Control
- Proto-Scale 3-2™ 3-Rail/2-Rail Conversion Capable
- Synchronized Puffing ProtoSmoke™ System
- Proto-Sound® 2.0 With The Digital Command System Featuring:- Freight Yard Proto-Effects™
- Unit Measures: 32 x 3 1/8 x 4 1/8
- Operates On O-72 Curves

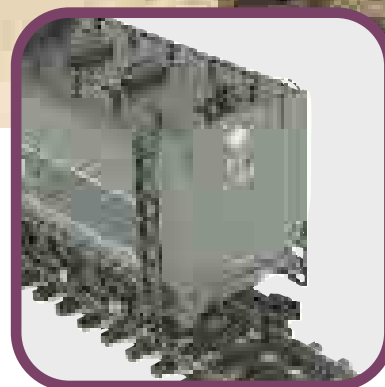



Union Pacific (Black)- 4-6-6-4 Challenger Steam Engine w/Proto-Sound® 2.0

20-3167-1	Hi-Rail Wheels	\$1399.95
20-3167-2	Scale Wheels	\$1399.95



Union Pacific (Two-Tone Gray w/Silver Stripes)- 4-6-6-4 Challenger Steam Engine w/Proto-Sound® 2.0

20-3168-1	Hi-Rail Wheels	\$1399.95
20-3168-2	Scale Wheels	\$1399.95



Clinchfield - 4-6-6-4 Challenger Steam Engine w/Proto-Sound® 2.0

20-3169-1	Hi-Rail Wheels	\$1399.95
20-3169-2	Scale Wheels	\$1399.95

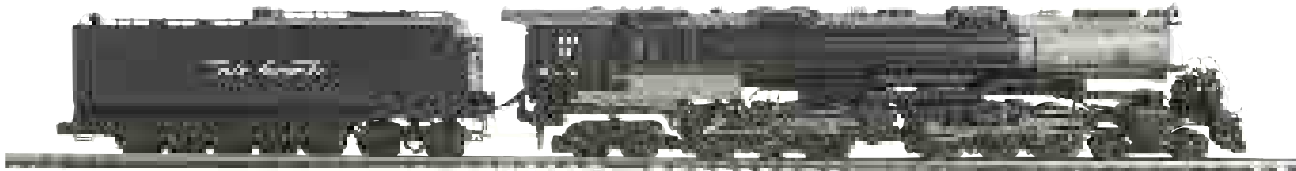

Denver Rio Grande - 4-6-6-4 Challenger Steam Engine w/Proto-Sound® 2.0

20-3170-1	Hi-Rail Wheels	\$1399.95
20-3170-2	Scale Wheels	\$1399.95

The first Challengers were conceived in 1936 as fast freight engines to replace the Union Pacific's fleet of three-cylinder 4-12-2 locomotives. With an extra center cylinder for added power and a top speed of 45 mph, the 4-12-2s had been successful freight engines when built in 1926. But a decade later they were considered slow and difficult to maintain. So American Locomotive Works (Alco) was commissioned to build what became one of the most successful fleets of articulated engines on any railroad. Forty Challengers were built in the 1930s. The pressure of wartime traffic brought an order for 65 more with bigger tenders and many minor improvements.

The Challengers were steam power at its zenith. They incorporated all the technology that represented super-power steam, including roller bearings on all axles and drive rods - but none of the foolishness that characterized some of the desperate efforts to save steam in the post-war years. Most Challengers were assigned to freight duty, but a number were designated for passenger service, hustling 20-car trains across mountains and deserts to California and Oregon at speeds up to 70mph.

It was in a roundabout way that six Challengers ordered by the UP ended up hauling coal through the Appalachians for the Clinchfield Railroad. In the midst of World War II, the War Production Board refused the Rio Grande's request to order new articulateds of its own design from Baldwin Locomotive Works. Instead, the Board diverted the last six Challengers in UP's order to the Rio Grande - which turned up its nose at the locos and decided to lease them for the duration rather than buying them. After war's end, the Rio Grande returned the unwanted engines to the government. In 1947, the War Assets Administration sold the orphan locos to the Atlantic Coast Line and Louisville & Nashville Railroads, which put the Challengers to work on their jointly-owned subsidiary, the Clinchfield, Carolina & Ohio. Thus a group of engines intended to speed over western deserts and mountains ended up thundering through Appalachia.

M.T.H. is proud to return the Challenger to the MTH Premier Line-up in the classic markings of the Union Pacific, Clinchfield, and Denver & Rio Grande Railroads. As with all 2005 Premier steam locomotives, the Challengers are equipped with the awesome sound and performance of Proto-Sound® 2.0, as well as the versatility of Proto-Scale 3-2™.

Premier Steam Engine



FEATURES

- Die-Cast Boiler and Tender Body
- 1:48 Scale Proportions
- Die-Cast Metal Chassis
- Authentic Paint Scheme
- Metal Wheels and Axles
- Constant Voltage Headlight
- Die-Cast Truck Sides
- Precision Pittman® Flywheel Equipped Motor
- Remote Controlled Proto-Coupler™
- Engineer and Fireman Figures
- Operating Firebox Glow
- Metal Handrails and Decorative Bell
- Decorative Metal Whistle
- Operating Marker Lights
- Lighted Cab Interior
- Operating Tender Back-up Light
- Locomotive Speed Control
- Synchronized Puffing ProtoSmoke™ System
- Proto-Scale 3-2™ 3-Rail/2-Rail Conversion Capable
- Proto-Sound® 2.0 With The Digital Command System Featuring: Freight Yard Proto-Effects™
- Unit Measures: 21" x 2 5/8" x 3 11/16"
- Operates On O-42 Curves





Santa Fe - 2-8-0 H-9 Consolidation Steam Engine w/Proto-Sound® 2.0
 20-3162-1 Hi-Rail Wheels \$799.95
 20-3162-2 Scale Wheels \$799.95

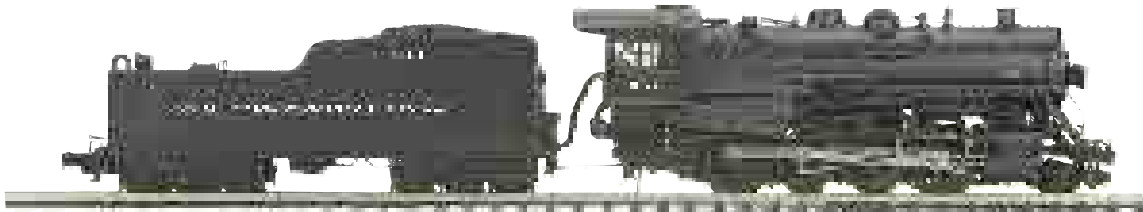

Pittsburgh & Lake Erie - 2-8-0 H-9 Consolidation Steam Engine w/Proto-Sound® 2.0
 20-3163-1 Hi-Rail Wheels \$799.95
 20-3163-2 Scale Wheels \$799.95

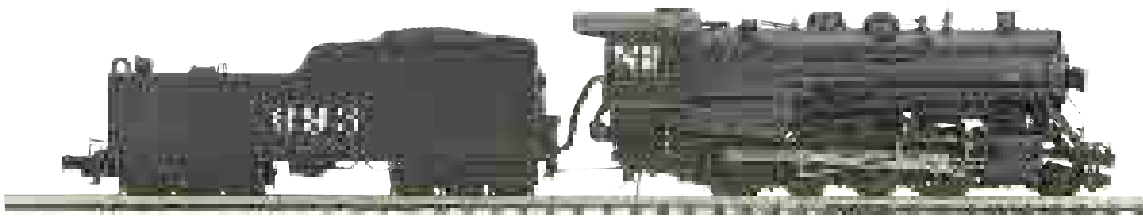

Illinois Central - 2-8-0 H-9 Consolidation Steam Engine w/Proto-Sound® 2.0
 20-3164-1 Hi-Rail Wheels \$799.95
 20-3164-2 Scale Wheels \$799.95

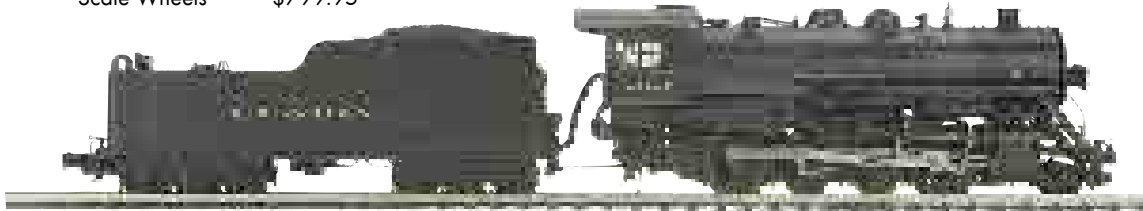

Reading - 2-8-0 H-9 Consolidation Steam Engine w/Proto-Sound® 2.0
 20-3165-1 Hi-Rail Wheels \$799.95
 20-3165-2 Scale Wheels \$799.95

Western Maryland - 2-8-0 H-9 Consolidation Steam Engine w/Proto-Sound® 2.0
 20-3166-1 Hi-Rail Wheels \$799.95
 20-3166-2 Scale Wheels \$799.95

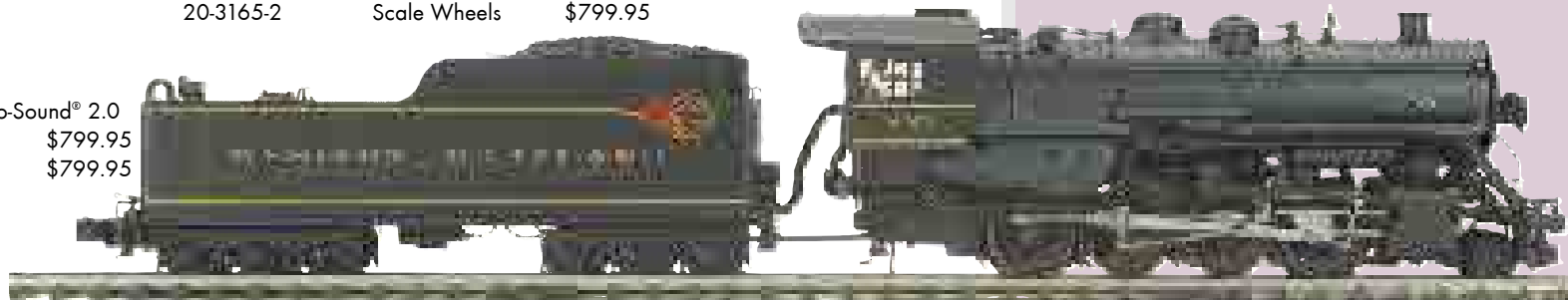

The Western Maryland's forte was moving heavy freight trains briskly through challenging territory. Railfans called it the Wild Mary and the road called itself the Fast Freight Line; both nicknames were appropriate. Using some of the nation's most modern steam power, the WM wrestled coal out of the Appalachian Mountains to its own tidewater terminal on the Chesapeake Bay. It also offered shippers the shortest route from the Great Lakes to the Atlantic seaboard. The road was known for keeping its motive power well maintained and freshly painted.

To help move coal out of the West Virginia and Maryland mountains, the Wild Mary bought the H-9 class of heavy consolidations from Baldwin in 1921. Born in the late 1800's, the 2-8-0 Consolidation wheel arrangement ultimately became one of the most popular freight engines of the steam era, reaching its peak use about the time the H-9s were constructed.

Built just before the dawning of "super-power" steam that combined power and speed, the H-9s were designed for brute strength. Weighing in at over 150 tons, they developed 71,500 pounds of tractive effort, more than enough power to pull a 100-car, 7,800-ton train. The Western Maryland ultimately obtained 50 of these coalhauling powerhouses, and several served until the end of steam in 1954.

The 2005 edition of this muscular steamer sports the distinctive "fireball" logo of the Western Maryland. Freight enthusiasts can also choose from four other roadnames. As with all 2005 Premier Line steam locomotives, the H-9 comes equipped with the awesome sounds and features of Proto-Sound® 2.0 and the versatility of Proto-Scale 3-2™.

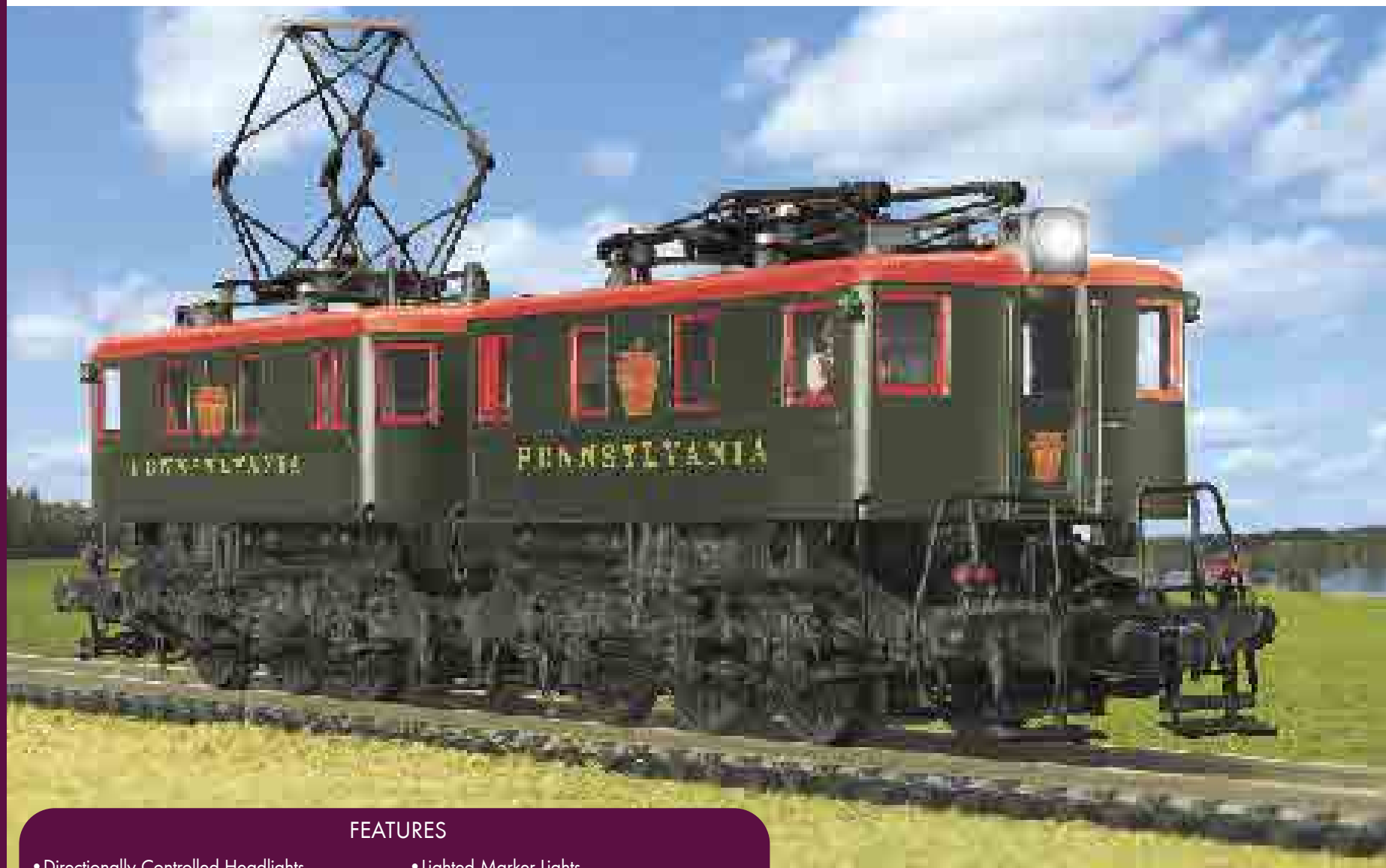

FEATURES

- Directionally Controlled Headlights
- Intricately Detailed Die-Cast Body
- Metal Wheels, Axles and Gears
- Die-Cast Truck Sides & Pilots
- (2) Remotely Controlled Proto-Couplers™
- Authentic Paint Scheme
- Metal Handrails and Decorative Horn
- (2) Precision Flywheel Equipped Motors
- Lighted Cab Interior
- Illuminated Number Boards
- Lighted Marker Lights
- (2) Engineer Cab Figures
- Operating Pantograph
- Locomotive Speed Control
- Proto-Sound® 2.0 With The Digital Command System Featuring:- Passenger Station Proto-Effects™
- Unit Measures: 12 3/4" x 3 3/4" x 2 1/2"
- Operates On O-54 Curves

**NUMBER 6 IN OUR
SERIES OF
PENNSYLVANIA
ELECTRICS**

NEW!



Pennsylvania - BB1 Electric w/ Proto-Sound® 2.0
20-5561-1 Hi-Rail Wheels \$699.95

NEW!

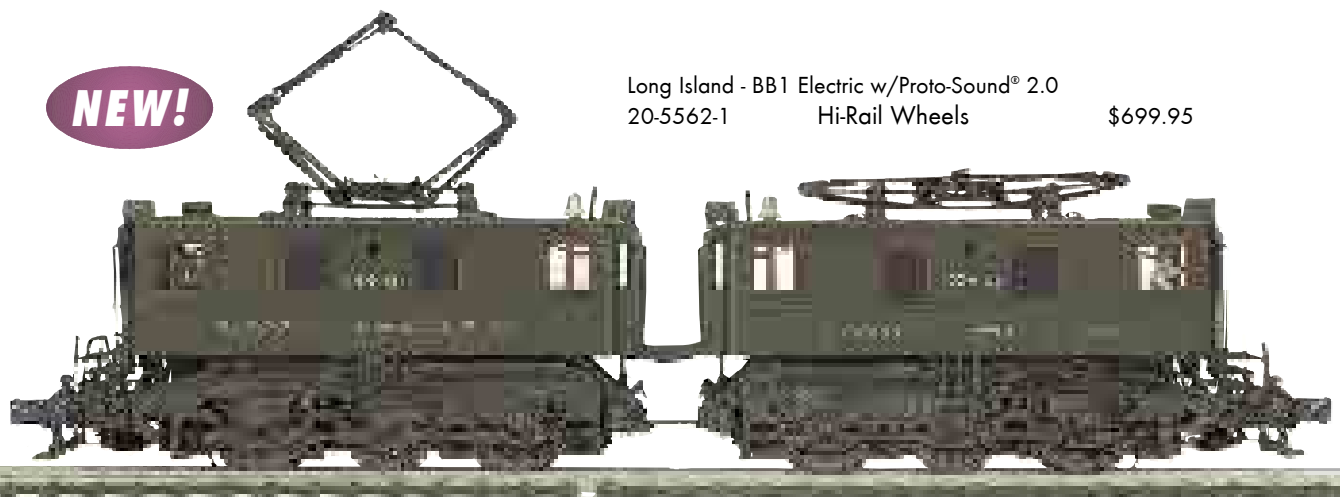

Long Island - BB1 Electric w/Proto-Sound® 2.0
20-5562-1 Hi-Rail Wheels \$699.95

As Al Stauffer writes in his book *Pennsy Power*, "the diminutive B1 with its single pantograph fully extended has the appearance of stretching mightily to reach its trolley wire power supply far overhead." He goes on to describe the little engine as looking more like a toy train than the real thing. And, indeed, its small size - the locomotive only measured a little more than 31' in length - relegated its use primarily to terminal work around New York and Philadelphia.

Pennsy's Altoona Shop built 42 of the 0-6-0 Box Cabs beginning in 1926. Designated Class BB1 by the Pennsylvania, a total of 31 units operated as pairs before later being split and reclassified as Class B1. Another 11 units were sent to the Long Island as Class BB3 to again work as pairs. Like the Pennsy, the Long Island later split up the units to singles and reclassified them as B3s.

While most electric engines usually sneak up on the unsuspecting because of their near-silent operation, the BB1 was very noisy for a switcher engine and was often mistaken for a locomotive ten times its size. The noise probably generated from the three single-phase traction motors that were direct geared to the trucks. Providing 570 horsepower and 13,500 pounds of tractive effort, the little switcher could only muster a top speed of 25 miles per hour.

Following on M.T.H.'s tradition of recreating railroading's history of unusual engines, the BB1 is sure to attract attention on anyone's layout! Making its debut in the Premier line, this fine scale replica is the sixth die-cast electric Pennsylvania prototype to appear in the M.T.H. line - a pace unmatched by other manufacturers - and is beautifully detailed to mimic the power and action of the real locomotive. Outfitted with the awesome sound and performance of Proto-Sound 2.0, it is sure to be the pride of your Pennsy collection for years to come.



Did You Know?

Because the prime mover of an E-unit diesel could be changed easily, these locomotives were given new engines throughout their service years.

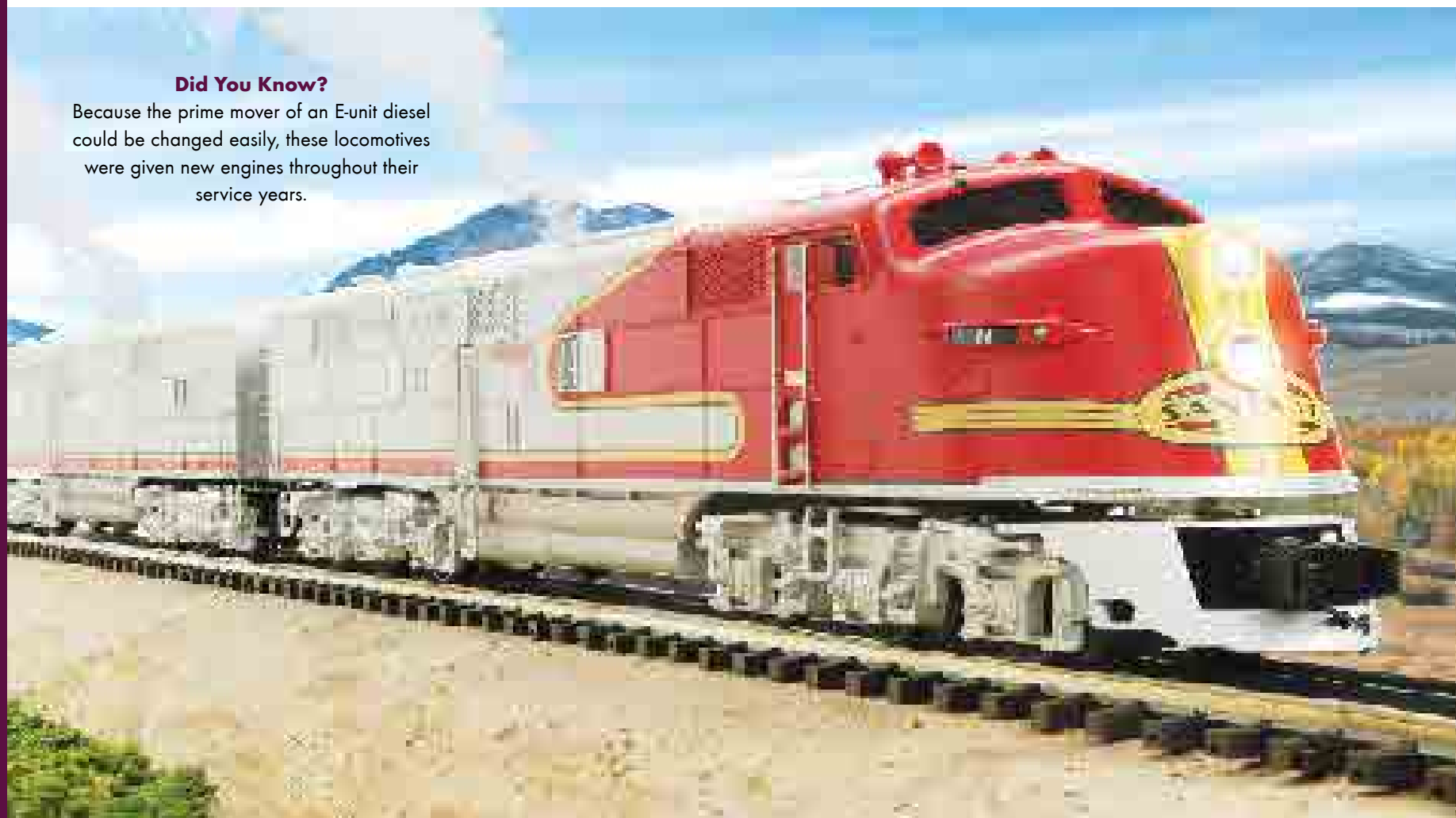

FEATURES

- (2) Remotely Controlled Proto-Couplers™
- Metal Chassis
- Illuminated Number Boards
- Directionally Controlled Headlights
- Die-Cast Truck Sides, Pilots and Fuel Tank
- Authentic Paint Scheme
- Metal Handrails and Decorative Horn
- Lighted Marker Lights
- Spinning Roof Fans
- Metal Body Side Grilles
- Intricately Detailed ABS Bodies
- Metal Wheels, Axles and Gears
- (2) Precision Flywheel Equipped Motors In Each A Unit
- Lighted Cab Interiors
- (2) Engineer Cab Figures In Each A Unit
- (2) Operating Smoke Units
- Locomotive Speed Control
- Proto-Sound® 2.0 With The Digital Command System Featuring:- Passenger Station Proto-Effects™
- Unit Measures: 53" x 2 1/2" x 3 1/2"
- Operates On O-31 Curves





Florida East Coast - E6 ABA Diesel Engine Set
 20-2545-1 Proto-Sound® 2.0 \$699.95
 20-2545-3 E6 B-Unit (Non-Powered) \$159.95

MATCHING PASSENGER SETS AVAILABLE
 SEE PAGE 134



Louisville & Nashville - E6 ABA Diesel Engine Set
 20-2546-1 Proto-Sound® 2.0 \$699.95
 20-2546-3 E6 B-Unit (Non-Powered) \$159.95



Santa Fe - E6 ABA Diesel Engine Set
 20-2547-1 Proto-Sound® 2.0 \$699.95
 20-2547-3 E6 B-Unit (Non-Powered) \$159.95



Chesapeake & Ohio - E6 ABA Diesel Engine Set
 20-2544-1 Proto-Sound® 2.0 \$699.95
 20-2544-3 E6 B-Unit (Non-Powered) \$159.95



In the mid-1930's, as the Electro-Motive Division of General Motors was trying to interest railroads in diesel passenger power, there was a lot of experimentation in exterior design. Looking at EMD's worm-like yellow and brown Union Pacific M-10000, its gleaming stainless steel Burlington Zephyr, or the boxy, just-plainly early Santa Fe units, it's apparent that here was a new function looking for its form. The first generation of road diesels found its form in 1937, when the initial E-units, built for the B&O, inaugurated the classic "covered wagon" cab unit design that would last for two decades on both freight and passenger diesels.

The earliest E-units were each virtually custom-made, with less than 20 units produced of models EA through E5. With the E6, EMD settled on a standardized passenger unit and began to produce it in large quantities. Starting in 1939, 92 A-units and 26 matching B-units were built, before the war effort arrested production of all passenger diesels in 1942. The E6 was the last passenger diesel to sport the beautiful, rakish, streamlined EMD nose so characteristic of the 1930s. When the war ended, EMD resumed production of the E-Series with the E7, which featured the "bulldog" nose introduced earlier on the model FT freight diesel.

Now you can enjoy the beauty and glamour of the seminal E6 streamliners in the colorful schemes of some of America's great railroads. Imagine the excitement of hearing station announcements and squealing brakes as your train glides to a stop, followed by the hustle and bustle of passengers disembarking and boarding. Moments later, the conductor's departure call pierces the din, the locomotive's bell begins to ring, and your train is off again for far-away places. It's all possible thanks to Proto-Sound® 2.0. Only M.T.H. offers such a complete array of sounds and other features to bring the drama of prototype railroading onto your home layout.



FEATURES

- Die-Cast Truck Sides, Pilots and Fuel Tank
- Metal Chassis
- Authentic Paint Scheme
- Metal Body Side Grilles
- Operating Pantographs
- Intricately Detailed Die-Cast Body
- Metal Wheels, Axles and Gears
- (2) Remotely Controlled Proto-Couplers™
- (2) Precision Flywheel Equipped Motors
- Locomotive Speed Control
- Lighted Cab Interior
- Illuminated Number Boards
- Lighted Marker Lights
- (2) Cab Figures
- Proto-Scale 3-2™ 3-Rail/2Rail Conversion Capable
- Proto-Sound® 2.0 With The Digital Command System Featuring:- Passenger Station Proto-Effects™
- Unit Measures: 20 3/4" x 4" x 2 3/4"
- Operates On O-42 Curves



Canadian National - EP-3 Electric Engine with Proto-Sound® 2.0

- 20-5556-1 Hi-Rail Wheels \$799.95
- 20-5556-2 Scale Wheels \$799.95

NEW!

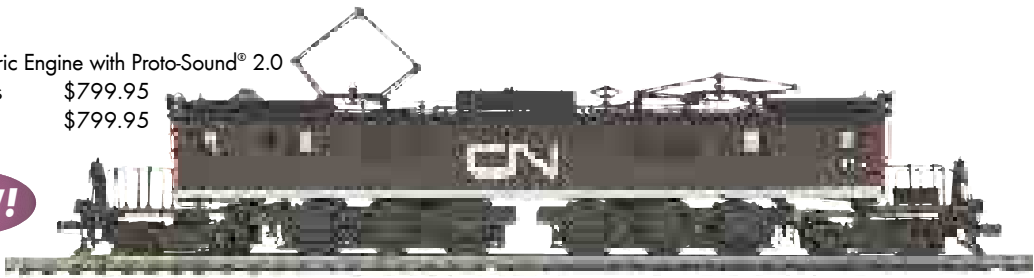

New Haven - EP-3 Electric Engine with Proto-Sound® 2.0

- 20-5557-1 Hi-Rail Wheels \$799.95
- 20-5557-2 Scale Wheels \$799.95

NEW!

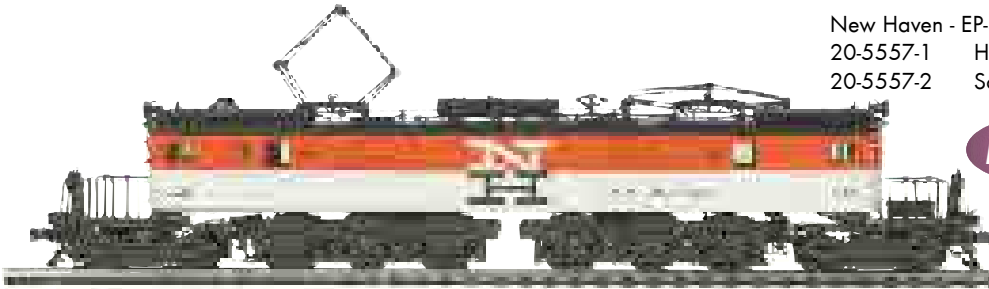

New Haven - EP-3 Electric Engine with Proto-Sound® 2.0

- 20-5558-1 Hi-Rail Wheels \$799.95
- 20-5558-2 Scale Wheels \$799.95

NEW!

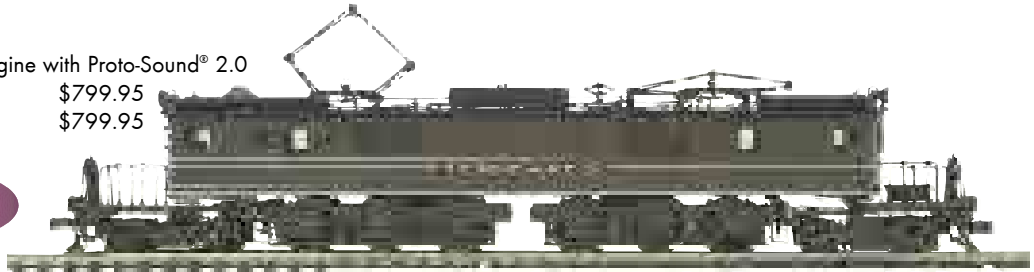

NY, NH & Hartford - EP-3 Electric Engine with Proto-Sound® 2.0

- 20-5559-1 Hi-Rail Wheels \$799.95
- 20-5559-2 Scale Wheels \$799.95

NEW!

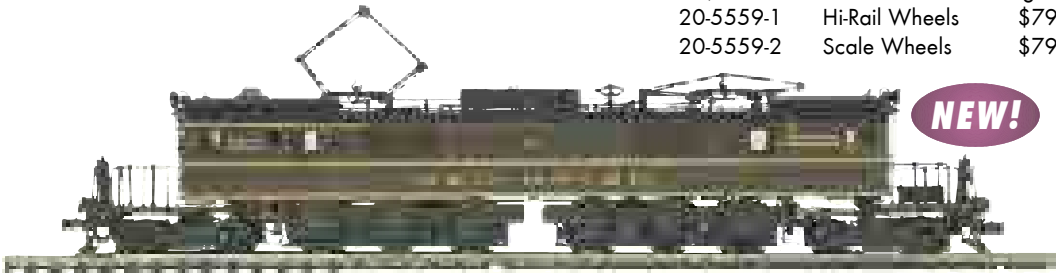

Virginian - EP-3 Electric Engine with Proto-Sound® 2.0

- 20-5560-1 Hi-Rail Wheels \$799.95
- 20-5560-2 Scale Wheels \$799.95

NEW!

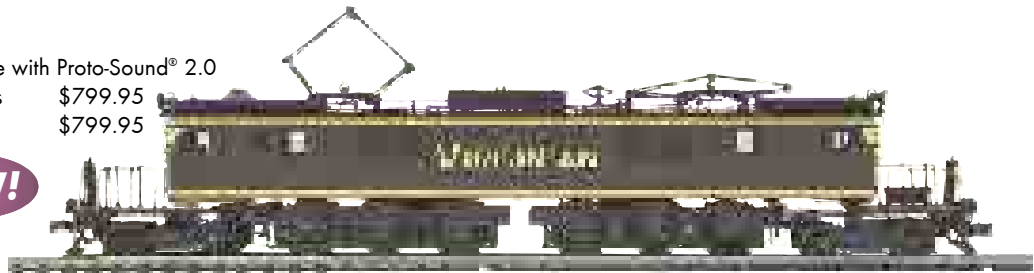

EP-3 Electric Engine

Although the Pennsylvania took pride in calling itself "The Standard Railroad of the World," its most famous locomotive had its roots in a General Electric-designed product borrowed from its much smaller neighbor to the north. The New York, New Haven & Hartford's ten rather plain-looking EP-3 electrics were the fathers of the Pennsy's legendary fleet of 139 GG1s.

Built in 1931, the EP-3 was General Electric's effort to steal the New Haven's business away from rival Westinghouse Electric - and it worked. The EP-3 could easily hurry 15 heavyweight Pullmans down the road at 70mph, and its success led the New Haven to purchase almost all future electric locomotives from GE. Bigger than any previous New Haven juice jacks, the EP-3 was, in electric locomotive parlance, a 2-C+C-2: a two-axle, unpowered guide truck at each end and a pair of three-axle powered trucks in the middle. Each driven axle was powered by two electric motors. The last box cab electrics built for the New Haven, the EP-3s were nicknamed "flat bottoms" by their crews.

While the EP-3's were thriving on the New Haven in the early 1930s, things were not going as well with the Pennsy's new electrification project. The P-5 electrics intended to be the road's signature passenger engines turned out to be short on power and possessed of tracking problems. The Pennsy borrowed several EP-3s for testing, built its own experimental prototype based on those engines, and, as they say, the rest is history. It is no coincidence that, below the body, a Pennsylvania GG1 and a New Haven EP-3 look very much the same. While the EP-3s did not last as long as the GG1s, they did have an extraordinarily long career, with the last EP-3 being retired in 1961.

The EP-3 debuts in the 2005 M.T.H. Premier line-up fully outfitted with Proto-Sound® 2.0. Featuring a die-cast body and chassis, the EP-3 also includes automatic operating pantographs. Watch as each pantograph extends or retracts when the locomotive changes direction. The pantographs are also fully controllable in command mode when using the DCS system.



NON-POWERED FEATURES

- Intricately Detailed ABS Body
- Metal Wheels and Axles
- (2) Operating Metal Couplers
- Die-Cast Truck Sides, Pilots and Fuel Tank
- Metal Handrails and Decorative Horn
- Spinning Roof Fans
- Metal Body Side Grilles
- (2) Cab Figures
- Unit Measures: 17 3/4" x 3 3/4" x 2 1/2"
- Operates On O-42 Curves

ADDITIONAL POWERED FEATURES

- Directionally Controlled Headlights
- Metal Gears
- (2) Remotely Controlled Proto-Couplers™
- Authentic Paint Scheme
- (2) Precision Flywheel Equipped Motors
- Lighted Cab Interior
- Illuminated Number Boards
- Lighted Marker Lights
- Operating Pantograph
- Locomotive Speed Control
- Proto-Sound® 2.0 With The Digital Command System Featuring:- Freight Yard Proto-Effects™



Chessie - SD50 Diesel Engine
 20-2576-1 Proto-Sound® 2.0 \$399.95
 20-2576-3 Non-Powered \$159.95



Chicago NorthWestern - SD50 Diesel Engine
 20-2577-1 Proto-Sound® 2.0 \$399.95
 20-2577-3 Non-Powered \$159.95



Conrail - SD50 Diesel Engine
 20-2578-1 Proto-Sound® 2.0 \$399.95
 20-2578-3 Non-Powered \$159.95



Denver & Rio Grande - SD50 Diesel Engine
 20-2579-1 Proto-Sound® 2.0 \$399.95
 20-2579-3 Non-Powered \$159.95



Norfolk Southern - SD50 Diesel Engine
 20-2580-1 Proto-Sound® 2.0 \$399.95
 20-2580-3 Non-Powered \$159.95

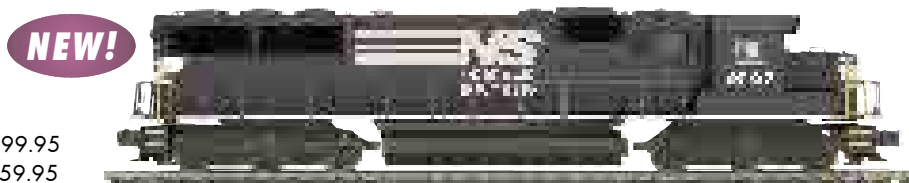

Union Pacific - SD50 Diesel Engine
 20-2581-1 Proto-Sound® 2.0 \$399.95
 20-2581-3 Non-Powered \$159.95



EMD's "50 Series" diesel locomotives of the mid-1980s were the product of the most extensive testing in the company's 50-year history. Both the four-axle, four-motor GP50 and the six-axle, six-motor SD50 utilized a new control system that substantially increased hauling capacity and reduced engine noise levels.

The 3500 hp SD50 measured just 30" longer than the SD40-2 it replaced but differed substantially in appearance. Gone were the front and rear "porches" of the SD40-2 and the dynamic brake blisters on the sides of its hood. Under the SD50's longer hood, the dynamic brakes, which generate a lot of heat, were relocated from a position over the hot engine to a cleaner, cooler area just behind the cab.

The SD50 also introduced EMD's new "Super Series" control system, which included a radar unit for measuring true ground speed and electronic monitoring of the electrical equipment. A primary benefit of the new control system was its ability to maximize rail adhesion by automatically applying short bursts of sand as needed to maintain traction. The system allowed three SD50s to do the work of four older locomotives.

The SD50 joins M.T.H.'s Premier Line diesel roster in 2005, fully outfitted with the power and performance of Proto-Sound® 2.0. Intricate detailing that includes see-thru body screens, wire grab irons, spinning roof fans, and opening doors ensures that the SD50 will look as fine as it performs.



NON-POWERED FEATURES

- Metal Wheels and Axles
- Metal Chassis
- Intricately Detailed ABS Body
- Die-Cast Truck Sides, Pilots and Fuel Tank
- Authentic Paint Scheme
- Metal Handrails and Decorative Horn
- Spinning Roof Fans
- Metal Body Side Grilles
- (2) Operating Metal Couplers
- (2) Cab Figures
- Unit Measures: 15 3/8" x 2 5/8" x 4"
- Operates On O-31 Curves

ADDITIONAL POWERED FEATURES

- (2) Remotely Controlled Proto-Couplers™
- Metal Chassis
- (2) Precision Flywheel Equipped Motors
- Illuminated Number Boards
- Directionally Controlled Headlights
- Lighted Cab Interior
- Lighted Marker Lights
- Metal Body Side Grilles
- Operating Smoke Unit
- Locomotive Speed Control
- Proto-Sound® 2.0 With The Digital Command System Featuring:- Freight Yard Proto-Effects™





Santa Fe - SD24 Diesel Engine

20-2582-1	Proto-Sound® 2.0	\$399.95
20-2582-3	Non-Powered	\$159.95

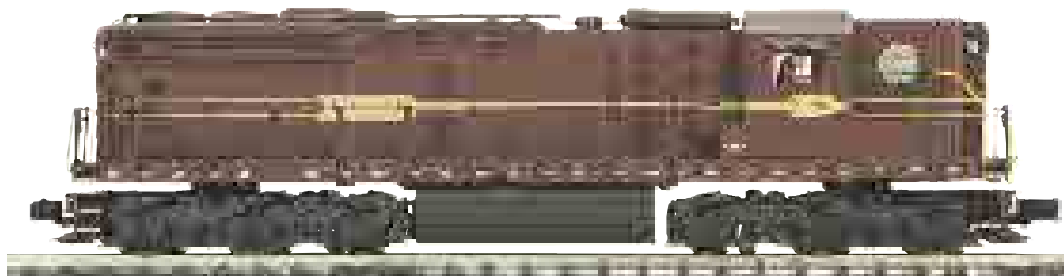

Duluth Missabe & Iron Range - SD24 Diesel Engine

20-2583-1	Proto-Sound® 2.0	\$399.95
20-2583-3	Non-Powered	\$159.95



Westinghouse - SD24 Diesel Engine

20-2584-1	Proto-Sound® 2.0	\$399.95
20-2584-3	Non-Powered	\$159.95



Burlington - SD24 Diesel Engine

20-2585-1	Proto-Sound® 2.0	\$399.95
20-2585-3	Non-Powered	\$159.95

In 1958, GM's Electro-Motive Division took a great technological stride forward with the introduction of the turbocharged SD24. In turbocharged engines, exhaust gases are used to power a turbine that increases cylinder air pressure, thus effectively increasing horsepower. In fact, the 16-cylinder model 567 diesel that produced 1800 horsepower in the normally aspirated SD18 locomotive was upgraded to 2400 horsepower in the turbocharged SD24.

Turbocharged engines also run better at varying altitudes, making them ideal for railroads that travel through changing terrain. Look on the left side of the SD24's hood for the semicircular bulge that marks the location of the turbine.

The SD24s were close relatives of the popular GP-series engines. The primary difference was that SD-series (for "Special Duty") locomotives were lengthened to make room for three-axle, three-motor trucks. For a GP and an SD engine of the same horsepower, the extra wheels on an SD locomotive gave it more tractive effort at low speeds and less engine weight on each axle. For this reason, the SD24 and others in the SD series were ideally suited for secondary lines with lighter rail.

Last cataloged in 2002, the SD24 returns to the Premier product line in 2005 in four exciting paint schemes each outfitted with the power and performance of Proto-Sound 2.0.

Premier Diesel Engine



NON-POWERED FEATURES

- Metal Chassis
- Intricately Detailed ABS Body
- Spinning Roof Fans
- Metal Body Side Grilles
- Die-Cast Truck Sides
- Colorful Paint Scheme
- Metal Handrails
- Metal Wheels and Axles
- (2) Operating Metal Couplers
- (2) Cab Figures
- Unit Measures: 18 3/8" x 2 7/8" x 3 15/16"
- Operates On O-31 Curves

ADDITIONAL POWERED FEATURES

- (2) Remotely Controlled Proto-Couplers™
- (2) Precision Flywheel Equipped Motors
- Operating Smoke Unit
- Metal Gears
- Lighted Cab Interior
- Illuminated Number Boards
- Lighted Marker Lights
- Operating Ditch Lights
- Locomotive Speed Control
- Proto-Sound® 2.0 With The Digital Command System Featuring:- Freight Yard Proto-Effects™



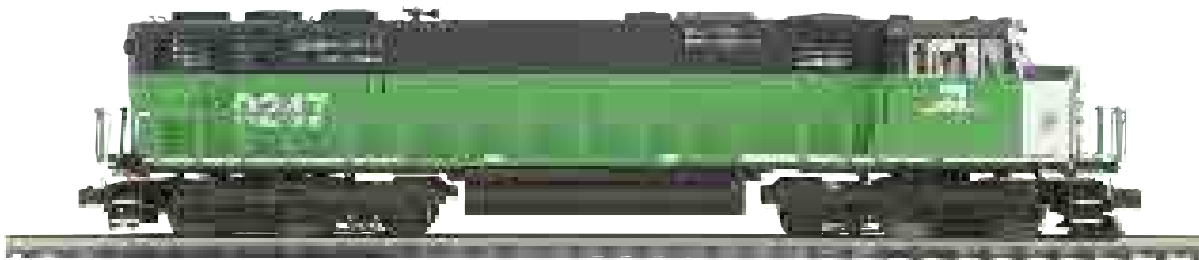

Burlington Northern - SD60M Diesel Engine

20-2572-1	Proto-Sound® 2.0	\$399.95
20-2572-3	Non-Powered	\$159.95

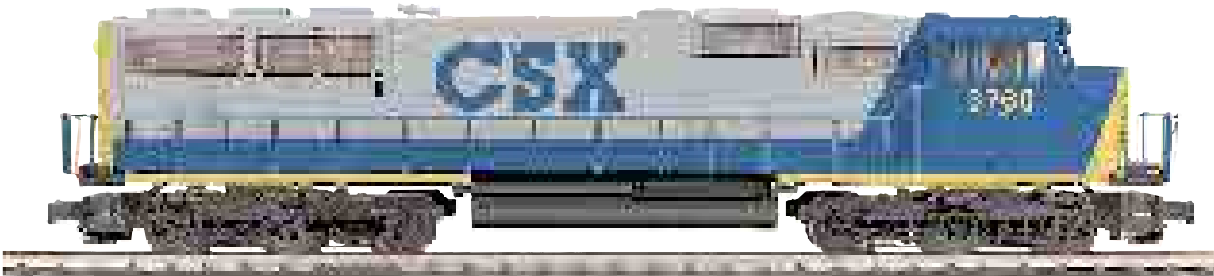

CSX - SD60M Diesel Engine

20-2573-1	Proto-Sound® 2.0	\$399.95
20-2573-3	Non-Powered	\$159.95



SOO Line - SD60M Diesel Engine

20-2574-1	Proto-Sound® 2.0	\$399.95
20-2574-3	Non-Powered	\$159.95

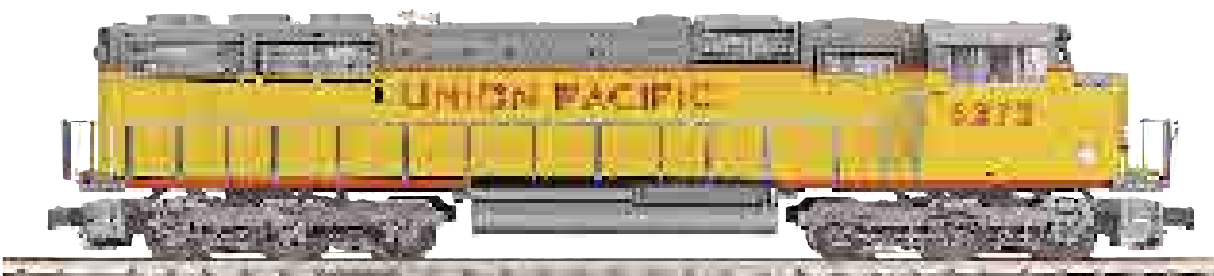

Union Pacific - SD60M Diesel Engine

20-2575-1	Proto-Sound® 2.0	\$399.95
20-2575-3	Non-Powered	\$159.95

Introduced in the mid-1980s, the SD60 and its four-axle sister, the GP60, were the first EMD diesels to incorporate computer technology and onboard diagnostics to aid the engineer. Under the hood was a 16-cylinder model 710 prime mover rated at 3800 horsepower. In January 1989, the Union Pacific Railroad accepted the initial order of SD60M's, featuring GM's version of the North American Safety Cab. The wide-nosed cab was relatively new to American rails but had been popular for some years with Canadian crews, who found it particularly cozy in the winter.

The Safety Cab underwent several changes in appearance over the years, with the transition from a three-piece windshield to a two-piece model one of the most obvious. Other upgrades included the addition of front number boards above the windshield and window glass in the nose-mounted cab access door.

The SD60M returns to the MTH lineup in 2005 in four paint schemes, each loaded with the added-on details and operating features that make M.T.H. Premier Line diesels a terrific value.

Did You Know?

EMD's SD50 diesel, introduced in 1980, had engine problems that led to the introduction of the SD60 just four years later. The SD50's model 645 prime mover was working so close to its limitations that the motor required a major overhaul every two years - twice as often as the motor in the previous SD40 and SD40-2 locomotives. Responding to customer complaints, EMD developed the stronger, more reliable model 710 prime mover introduced in the SD60 diesel.



Harley-Davidson® Goods, Registered Trademark of H-D Michigan, Inc.
© H-D®. All Rights Reserved.



SET FEATURES:

- SD60M Diesel
- (2) 2-Car Spine Car Sets w/Container
- Extended Vision Caboose

LOCOMOTIVE FEATURES:

- Intricately Detailed ABS Body
- Colorful Paint Scheme
- Metal Handrails
- Metal Chassis
- Die-Cast Truck Sides, Pilots and Fuel Tank
- (2) Remotely Controlled Proto-Couplers™
- (2) Precision Flywheel Equipped Motors

- Metal Wheels, Axles and Gears
- Directionally Controlled Headlights
- Locomotive Speed Control
- Lighted Cab Interior
- Illuminated Number Boards
- Lighted Marker Lights
- (2) Engineer Cab Figures
- Spinning Roof Fans
- Metal Body Side Grilles
- Operating Ditch Lights
- Operating Smoke Unit
- Operates On O-42 Track
- Proto-Sound® 2.0 With The Digital Command System Featuring:- Freight Yard Proto-Effects™

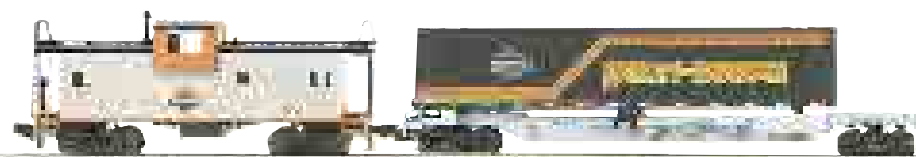
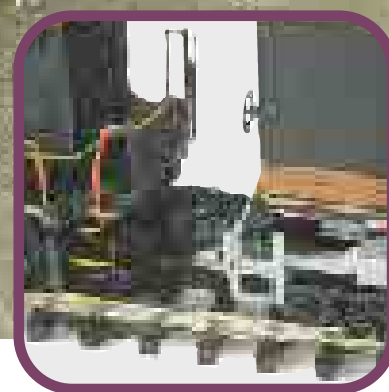

Put your railroad to work with this very unique Harley-Davidson® diesel freight collector set. Bearing the markings of the most famous motorcycle manufacturer in the world, this set is a must-have for any motorcycle or model railroading enthusiast.

Headed up by a powerful SD60M diesel engine decorated in stunning black and orange livery, there will be no mistaking the destination of this train as it pulls its four spine cars and a trailing caboose to the local Harley-Davidson® dealership. Outfitted with all-metal wheels and gears, the two-motored diesel runs as good as it looks and comes equipped with digital sound and revolutionary speed control features found only in Proto-sound 2.0. We've even included the trademarked sounds of a Harley-Davidson® motorcycle in the sound file for an added touch of realism sure to make this set a favorite of all who hear and see it run.

Did You Know?

EMD's SD50 diesel, introduced in 1980, had engine problems that led to the introduction of the SD60 just four years later. The SD50's model 645 prime mover was working so close to its limitations that the motor required a major overhaul every two years - twice as often as the motor in the previous SD-40 and SD40-2 locomotives. Responding to customer complaints, EMD developed the stronger, more reliable model 710 prime mover introduced in the SD60 diesel.



Harley-Davidson® - SD60M Diesel Engine
20-2595-3 Non-Powered \$179.95



Harley-Davidson® - #193 Industrial Water Tower with Flashing Light
30-90110 \$49.95



Harley-Davidson® - 2-Car Spine Car Set w/(2) 48' Containers
20-95045 \$119.95

NEW!

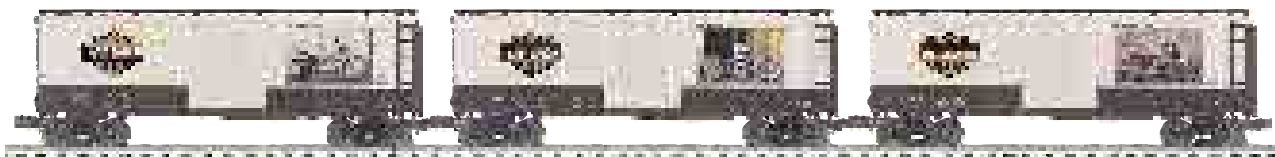

Harley-Davidson® - 3 Car Box Car Set
20-90173 \$149.95



Harley-Davidson® - Motorcycle Dealership
30-90111 \$59.95

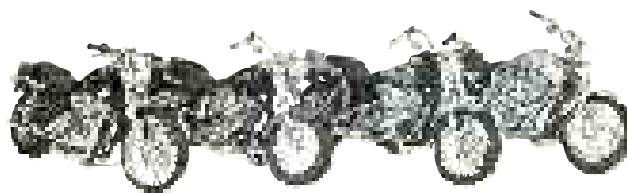

Harley-Davidson® - 4-Pack Motorcycle Set
30-90126 \$19.95



Harley-Davidson® - SD60M Diesel Engine Box Set
20-2595-1 Proto-Sound® 2.0 \$649.95

Premier Freight

M.T.H. Premier O Scale freight cars are the perfect complement to any manufacturer's scale proportioned O Gauge locomotives. Whether you prefer to purchase cars separately or assemble a unit train, M.T.H. Premier Rolling Stock has the cars for you in a variety of car types and paint schemes.

Virtually every sturdy car is offered in two car numbers which makes it even easier than ever to combine them into a multi-car consist. Many of M.T.H.'s Premier Rolling Stock offerings can also operate on the tightest O Gauge curves giving them even more added versatility to your layout.



2-Rail Bettendorf Freight Car Two Truck Pack
20-89001 \$12.99

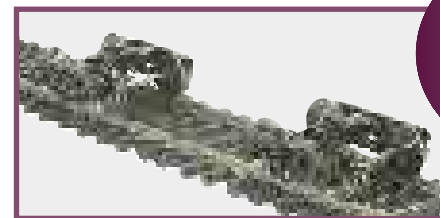

2-Rail Roller Bearing Freight Car Two Truck Pack
20-89002 \$12.99

**CONVERT YOUR
ROLLING STOCK TO
2-RAIL**
VISIT WWW.MTHTRAINS.COM
FOR A LIST OF
CONVERTIBLE CARS

Premier Line operating freight cars add a new dimension and excitement level to your O Gauge layout with realistic action and quiet smooth operation in a way other operating cars cannot.

Each car comes to life when parked on an operating track section. When the track section is activated, the car door slowly slides open and a dock worker begins offloading the reefer car's cargo. Naturally, the contents are cold and as the door opens a blast of cold misty air escapes. Fortunately, our man is on the job and the door slowly slides shut when he steps back inside the car ensuring that the rest of the cargo doesn't perish.



Burlington - Operating Reefer Car w/Signal Man
20-94085 \$69.95



**SEE THIS CAR IN
OPERATION AT
WWW.MTHTRAINS.COM**

FEATURES

- Metal Wheels and Axles
- Die-Cast 4-Wheel Trucks
- Operating Die-Cast Metal Couplers
- Colorful, Attractive Paint Schemes
- Decorative Brake Wheels
- Fast-Angle Wheel Sets
- Needle-Point Axles
- Operating Interior Lighting
- Intricately Detailed Durable ABS Body
- Unit Measures: 11 5/8" x 2 1/2" x 3 3/16"
- Operates On O-31 Curves



Pacific Fruit Express - Operating Reefer Car w/Signal Man
20-94086 \$69.95



Moving freight has always been the railroad's primary job - whether it be people or objects. When the automobile and trucking industry really began to take off, the railroads suffered from a loss of traffic. But as time passed, it became clear to the transportation industry that the railroad was still an efficient means to move freight.

Today, it's not uncommon to sit at a crossing and see hundreds of flat cars with trailers passing you by. The M.T.H. Premier Line features several scale proportioned truck trailers mounted atop flat cars to capture this vital aspect of freight movement. Choose from 10 different flat cars each equipped with a unique load.



Harley-Davidson® - 2-Car Spine Car Set w/(2) 48' Containers
20-95045 \$119.95

NEW!



Harley-Davidson® Goods, Registered Trademark of H-D Michigan, Inc.
© H-D®. All Rights Reserved.

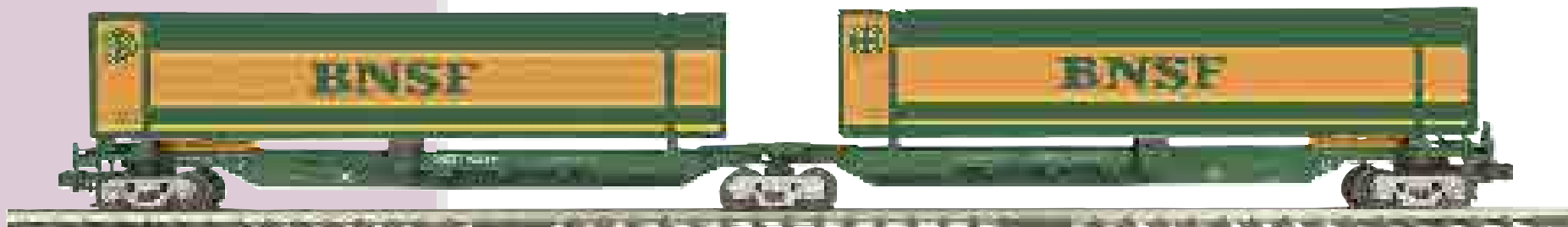

NEW!

BNSF - 2-Car Spine Car Set w/(2) 48' Containers
20-95046 \$99.95

FEATURES

- Intricately Detailed Durable ABS Bodies
- Metal Wheels and Axles
- Die-Cast 4-Wheel Trucks
- Operating Die-Cast Metal Couplers
- Colorful, Attractive Paint Schemes
- Fast-Angle Wheel Sets
- Needle-Point Axles
- Scale Proportioned Loads
- Unit Measures: 28" x 2 7/16" x 4"
- Operates On O-31 Curves

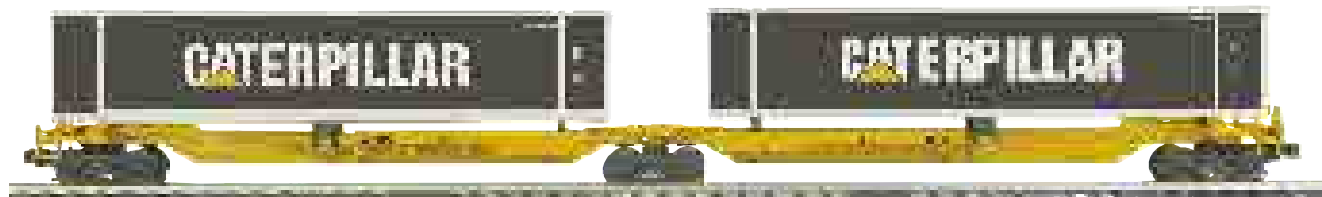

Caterpillar - 2-Car Spine Car Set w/(2) 48' Containers
20-95047 \$119.95

NEW!

©2004 Caterpillar
CAT, Caterpillar, and their design marks are registered trademarks of Caterpillar Inc.

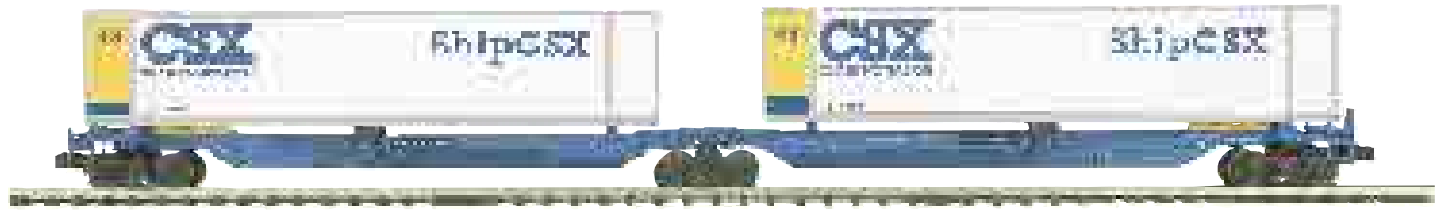

NEW! CSX - 2-Car Spine Car Set w/(2) 48' Containers
20-95048 \$99.95

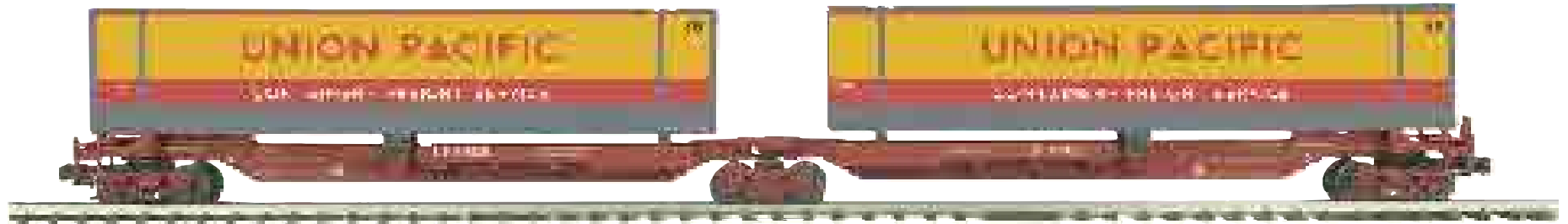

Union Pacific - 2-Car Spine Car Set w/(2) 48' Containers
20-95050 \$99.95 **NEW!**

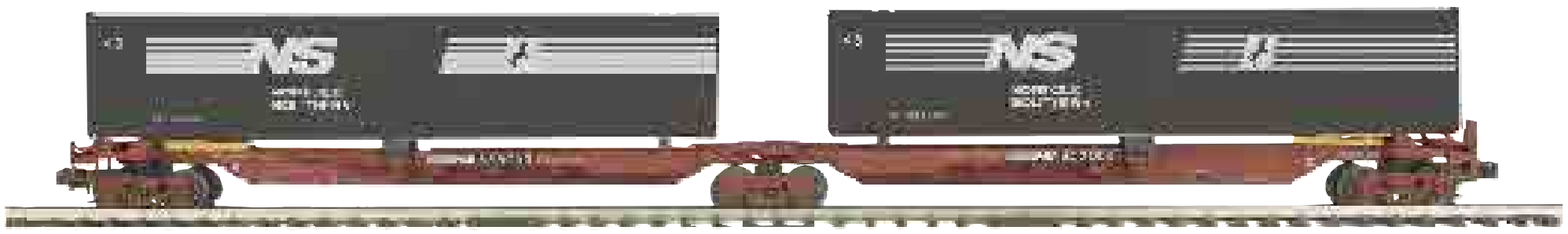

NEW! Norfolk Southern - 2-Car Spine Car Set w/(2) 48' Containers
20-95049 \$99.95

Twelve different hopper car designs in over 210 different paint schemes have appeared in M.T.H.'s Premier Line since 1997. An entirely new car was introduced in 2004 and 20 more paint schemes appear in 2005.

Featuring intricate but durable body details, separate wire form handrails and undercarriage detail guaranteed to appeal to even the most discriminating freight car lover ensure that M.T.H. hopper cars will find a place on many a scale pike.

FEATURES

- Intricately Detailed Durable ABS Body
- Metal Wheels and Axles
- Die-Cast 4-Wheel Trucks
- Operating Die-Cast Metal Couplers
- Colorful, Attractive Paint Schemes
- Fast-Angle Wheel Sets
- Needle-Point Axles
- 1:48 Scale Dimensions
- Operates On O-31 Curves

3-BAY CYLINDRICAL HOPPER CAR

- Unit Measures: 12 1/16" x 2 11/16" x 3 13/16"

50' AIRSLIDE HOPPER CAR

- Unit Measures: 13 5/8" x 2 11/16" x 3 11/16"

4-BAY HOPPER CAR

- Unit Measures: 13 1/4" x 2 5/8" x 3"



New York Central - 3-Bay Cylindrical Hopper Car
20-97561 \$44.95



Baltimore & Ohio - 3-Bay Cylindrical Hopper Car
20-97560 \$44.95



Reading - 3-Bay Cylindrical Hopper Car
20-97562 \$44.95



Western Pacific - 3-Bay Cylindrical Hopper Car
20-97563 \$44.95



GACX - 50' Airslide Hopper Car
20-97569 \$44.95



Denver Rio Grande Western - 50' Airslide Hopper Car
20-97570 \$44.95



GATX - 50' Airslide Hopper Car
20-97571 \$44.95



Northern Pacific - 50' Airslide Hopper Car
20-97572 \$44.95

Hopper Cars



Wisconsin Central - 4-Bay Hopper Car
20-97568 \$44.95



Monon - 4-Bay Hopper Car
20-97566 \$44.95



Chicago NorthWestern - 4-Bay Hopper Car
20-97565 \$44.95



Chessie - 4-Bay Hopper Car
20-97564 \$44.95



Pittsburgh & Lake Erie - 4-Bay Hopper Car
20-97567 \$44.95



Sunoco - 33K Gallon Tank Car
20-96114 \$44.95



Five different models in over 120 different paint schemes have appeared in the Premier Line tank car category over the past ten years. Like all Premier Line rolling stock, all feature crisp deco, intricately detailed yet durable ABS bodies, die-cast sprung metal trucks with metal operating couplers.

Over the next three pages, we've added 12 new paint schemes to our roster. When compared with other tank cars on the market, you won't find a better detailed more durable model from anyone because Premier Line freight cars are great looking and built to last.



Airco - 33K Gallon Tank Car
20-96111 \$44.95



NASA - 33K Gallon Tank Car
20-96113 \$44.95



Chevron USA - 33K Gallon Tank Car
20-96112 \$44.95

- ### FEATURES
- Intricately Detailed Durable ABS Bodies
 - Metal Wheels and Axles
 - Die-Cast 4-Wheel Trucks
 - Operating Die-Cast Metal Couplers
 - Colorful, Attractive Paint Schemes
 - Decorative Brake Wheels
 - Separate Metal Handrails
 - Fast-Angle Wheel Sets
 - Needle-Point Axles
 - Unit Measures: 17 5/8" x 2 1/2" x 4"
 - Operates On O-42 Curves



Shamrock Oil & Gas - 8000 Gallon Tank Car
20-96118 \$42.95



Milwaukee Road - 8000 Gallon Tank Car
20-96117 \$42.95



Atlantic Gasoline - 8000 Gallon Tank Car
20-96115 \$42.95



CSX - 8000 Gallon Tank Car
20-96116 \$42.95

FEATURES

- Intricately Detailed Durable ABS Bodies
- Metal Wheels and Axles
- Die-Cast 4-Wheel Trucks
- Operating Die-Cast Metal Couplers
- Colorful, Attractive Paint Schemes
- Decorative Brake Wheels
- Separate Metal Handrails
- Fast-Angle Wheel Sets
- Needle-Point Axles
- Unit Measures: 9 1/16 x 2 3/4 x 3 7/8
- Operates On O-27 Curves

FEATURES

- Intricately Detailed Durable ABS Bodies
- Metal Wheels and Axles
- Die-Cast 4-Wheel Trucks
- Operating Die-Cast Metal Couplers
- Colorful, Attractive Paint Schemes
- Separate Metal Handrails
- Fast-Angle Wheel Sets
- Needle-Point Axles
- Unit Measures: 12" x 2 3/4" x 4 3/16"
- Operates On O-27 Curves



Skelly Oil Company - Tank Car
20-96121 \$44.95



New Haven - Tank Car
20-96120 \$44.95



Minneapolis & St. Louis - Tank Car
20-96119 \$44.95



Tidewater Oil Company (Tydol) - Tank Car
20-96122 \$44.95

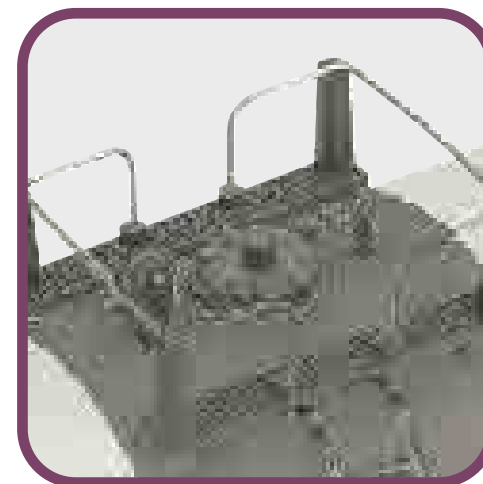



Chessie - Coil Car
20-98427 \$44.95

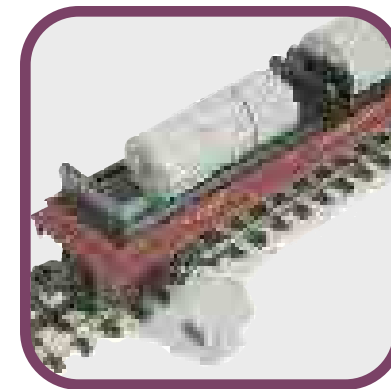
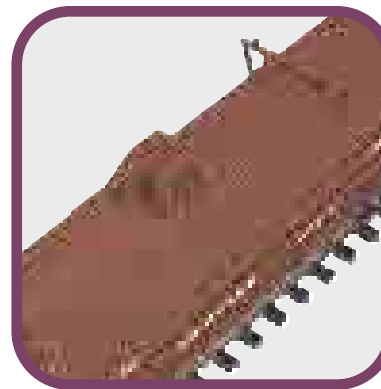

Southern - Coil Car
20-98430 \$44.95



Detroit, Toledo & Ironton - Coil Car
20-98428 \$44.95

FEATURES

- Intricately Detailed Durable ABS Bodies
- Metal Wheels and Axles
- Die-Cast 4-Wheel Trucks
- Operating Die-Cast Metal Couplers
- Colorful, Attractive Paint Schemes
- Decorative Brake Wheels
- Fast-Angle Wheel Sets
- Needle-Point Axles
- Unit Measures: 13" x 2 1/2" x 3 3/4"
- Operates On O-31 Curves



Ohio Central - Coil Car
20-98429 \$44.95



Chicago, St. Paul, Minneapolis & Omaha - 40' AAR Box Car
20-93226 \$44.95

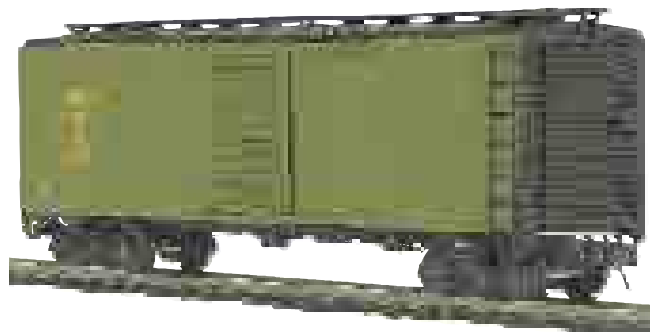

Canadian National - 40' AAR Box Car
20-93225 \$44.95



Great Northern - 40' AAR Box Car
20-93228 \$44.95

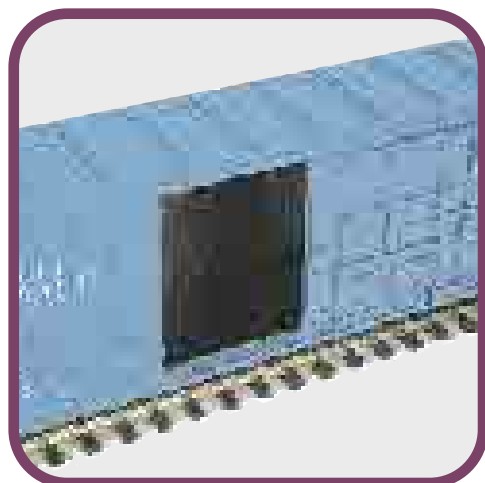

Florida East Coast - 40' AAR Box Car
20-93227 \$44.95

Seven different box car models in 202 different paint schemes have been produced by M.T.H. in our Premier Line since 1996 giving railroaders a huge array of choices unmatched by others during this same time frame. Most of the decoration used on Premier Line cars are faithful recreations of actual prototypes. Others have benefited from the creative input of our artwork designers. All feature crisp deco, intricately detailed yet durable ABS bodies, die-cast sprung metal trucks with metal operating couplers. These attributes ensure that these cars not only look good, they'll handle the wear and tear for years to come.

FEATURES

- Intricately Detailed Durable ABS Bodies
- Metal Wheels and Axles
- Die-Cast 4-Wheel Trucks
- Operating Die-Cast Metal Couplers
- Colorful, Attractive Paint Schemes
- Decorative Brake Wheels
- Separate Metal Handrails
- Fast-Angle Wheel Sets
- Needle-Point Axles
- Sliding Car Doors
- Stamped Metal Floors
- Operates On O-31 Curves
- Unit Measures: 11 1/2" x 2 5/8" x 3 3/4"



Western Maryland - 40' AAR Box Car
20-93232 \$44.95



New Haven - 40' AAR Box Car
20-93229 \$44.95



Southern Pacific - 40' AAR Box Car
20-93231 \$44.95



Pennsylvania - 40' AAR Box Car
20-93230 \$44.95

FEATURES

- Intricately Detailed Durable ABS Bodies
- Metal Wheels and Axles
- Die-Cast 4-Wheel Trucks
- Operating Die-Cast Metal Couplers
- Colorful, Attractive Paint Schemes
- Decorative Brake Wheels
- Separate Metal Handrails
- Fast-Angle Wheel Sets
- Needle-Point Axles
- Sliding Car Doors
- Stamped Metal Floors
- Operates On O-31 Curves
- Unit Measures: 11 1/2" x 2 5/8" x 3 3/4"

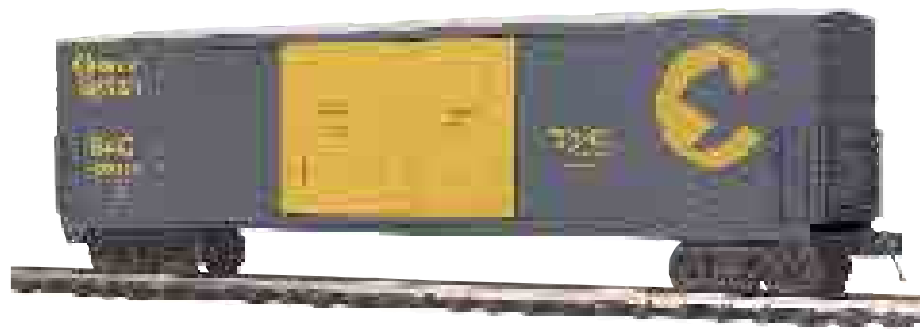
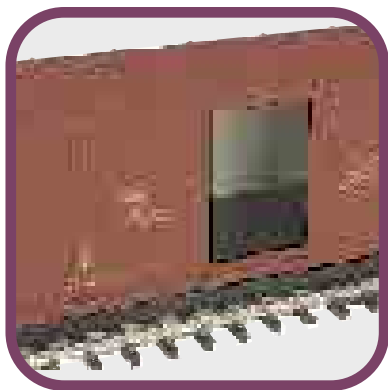

Chessie - 50' Dbl. Door Plugged Boxcar
20-93234 \$49.95

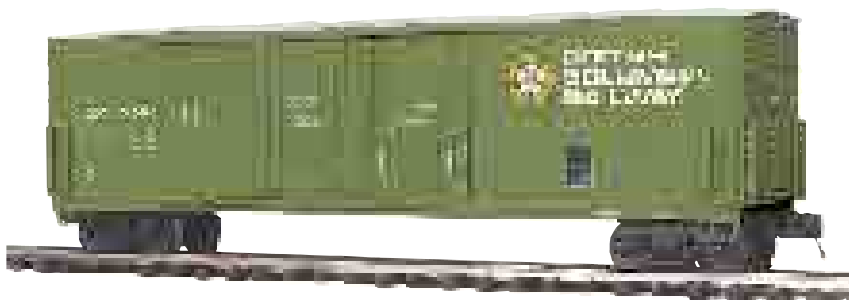

British Columbia Railway - 50' Dbl. Door Plugged Boxcar
20-93233 \$49.95

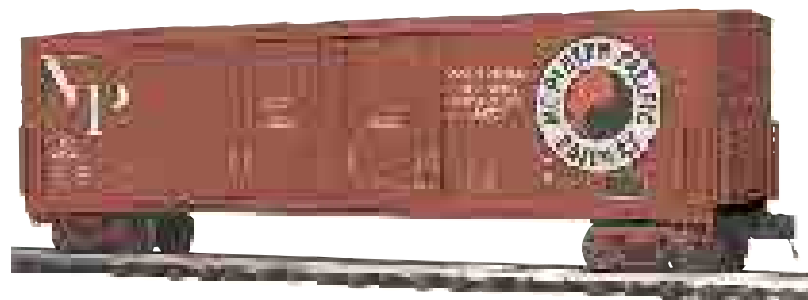

Northern Pacific - 50' Dbl. Door Plugged Boxcar
20-93236 \$49.95



Green Bay & Western - 50' Dbl. Door Plugged Boxcar
20-93235 \$49.95

FEATURES

- Intricately Detailed Durable ABS Bodies
- Metal Wheels and Axles
- Die-Cast 4-Wheel Trucks
- Operating Die-Cast Metal Couplers
- Colorful, Attractive Paint Schemes
- Decorative Brake Wheels
- Separate Metal Handrails
- Fast-Angle Wheel Sets
- Needle-Point Axles
- Sliding Car Doors
- Operates On O-31 Curves
- Unit Measures: 14 1/8" x 2 11/16" x 3 15/16"



New York Central - 50' High Cube Box Car
20-93224 \$49.95



Great Northern - 50' High Cube Box Car
20-93237 \$49.95

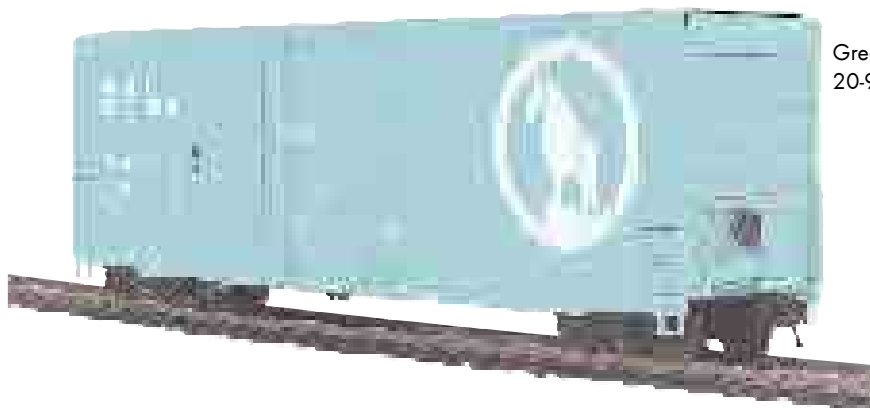

Canadian National - 50' High Cube Box Car
20-93238 \$49.95

FEATURES

- Intricately Detailed Durable ABS Bodies
- Metal Wheels and Axles
- Die-Cast 4-Wheel Trucks
- Operating Die-Cast Metal Couplers
- Colorful, Attractive Paint Schemes
- Decorative Brake Wheels
- Separate Metal Handrails
- Fast-Angle Wheel Sets
- Needle-Point Axles
- Sliding Car Doors
- Stamped Metal Floors
- Operates On O-31 Curves

50' HIGH CUBE BOX CAR

- Unit Measures: 14 1/2" x 2 5/8" x 4 3/16"

55' ALL-DOOR BOX CAR

- Unit Measures: 15 1/8" x 2 9/16" x 4 1/16"



Celotex - 55' All-Door Box Car
20-93240 \$49.95



North American Car Corp. - 55' All-Door Box Car
20-93242 \$49.95

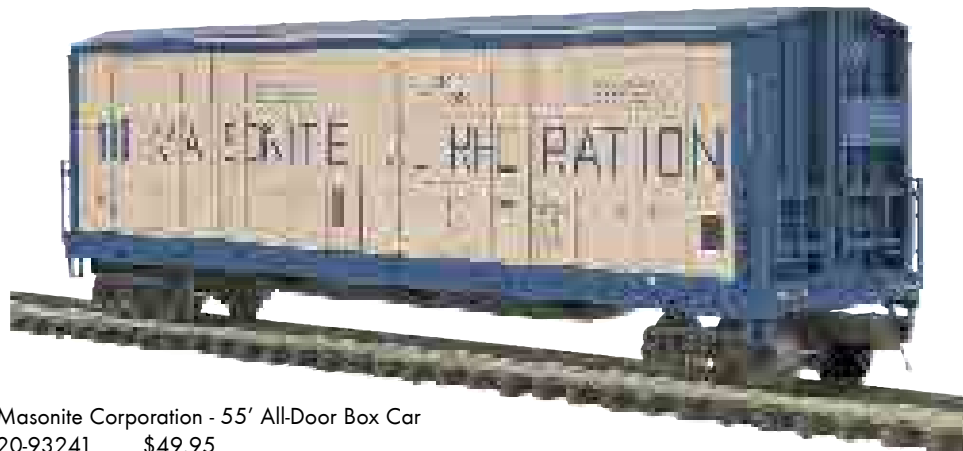

Masonite Corporation - 55' All-Door Box Car
20-93241 \$49.95



Weyerhaeuser - 55' All-Door Box Car
20-93243 \$49.95

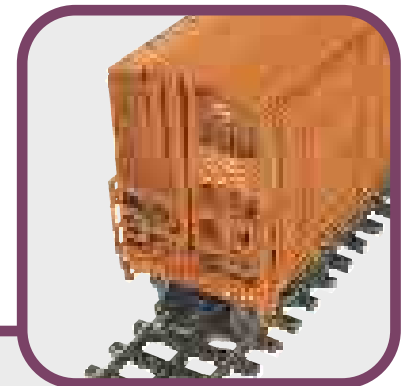

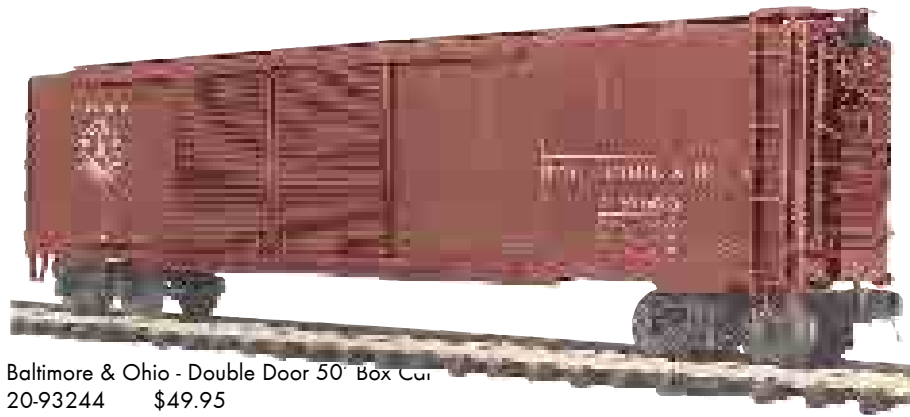

Baltimore & Ohio - Double Door 50' Box Car
20-93244 \$49.95

FEATURES

- Intricately Detailed Durable ABS Bodies
- Metal Wheels and Axles
- Die-Cast 4-Wheel Trucks
- Operating Die-Cast Metal Couplers
- Colorful, Attractive Paint Schemes
- Decorative Brake Wheels
- Separate Metal Handrails
- Fast-Angle Wheel Sets
- Needle-Point Axles
- Sliding Car Doors
- Stamped Metal Floors
- Operates on O-31 Curves
- Unit Measures: 14 1/8" x 2 3/4" x 3 7/8"

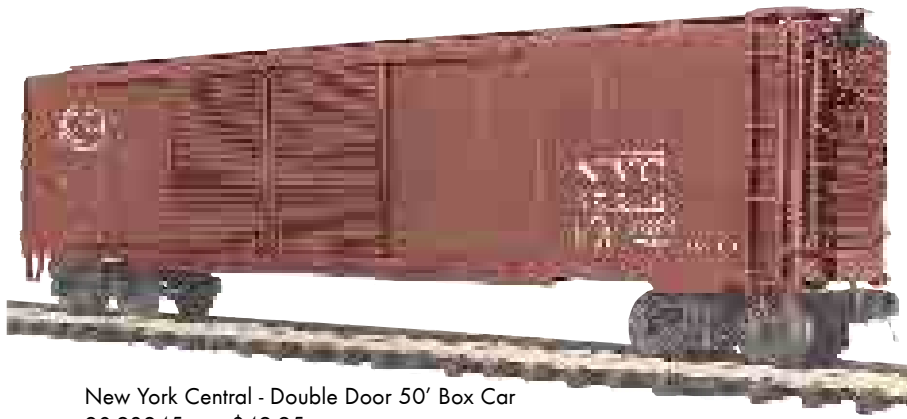

New York Central - Double Door 50' Box Car
20-93245 \$49.95

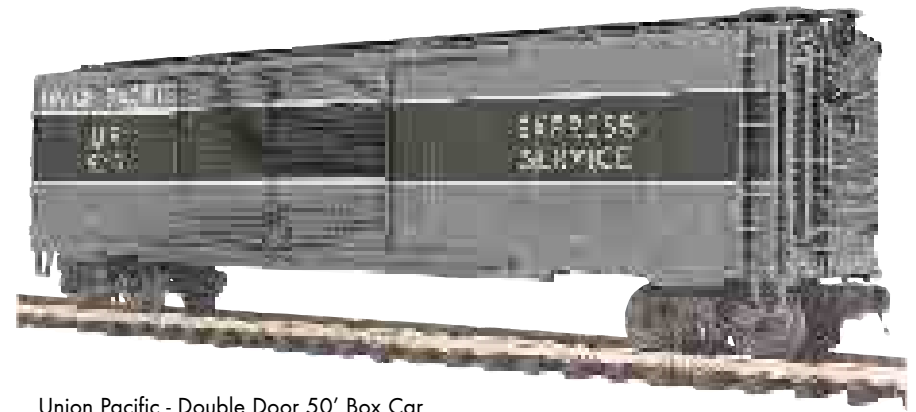

Union Pacific - Double Door 50' Box Car
20-93247 \$49.95

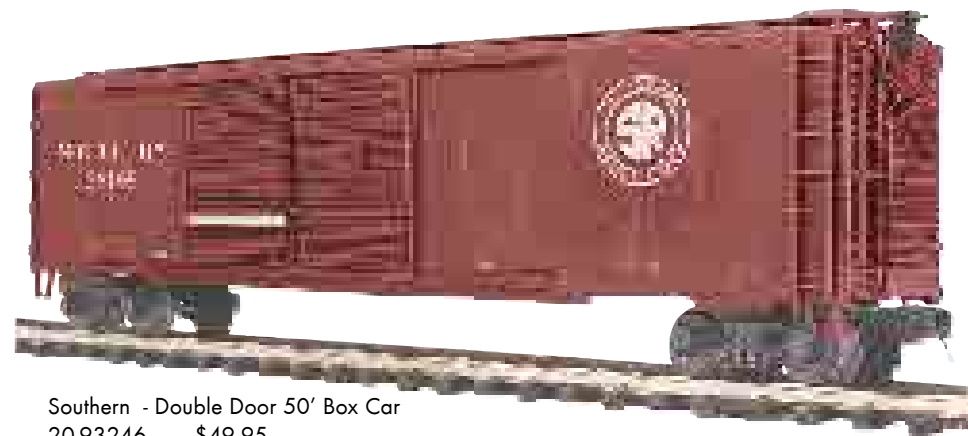

Southern - Double Door 50' Box Car
20-93246 \$49.95



Santa Fe - 40' Steel Sided Reefer Car
20-94089 \$44.95



Railway Express Agency - 40' Steel Sided Reefer Car
20-94090 \$44.95



American Refrigerator Transit Co. - 40' Steel Sided Reefer Car
20-94087 \$44.95

FEATURES

- Intricately Detailed Durable ABS Bodies
- Metal Wheels and Axles
- Die-Cast 4-Wheel Trucks
- Operating Die-Cast Metal Couplers
- Colorful, Attractive Paint Schemes
- Decorative Brake Wheels
- Separate Metal Handrails
- Fast-Angle Wheel Sets
- Needle-Point Axles
- Sliding Car Doors
- Stamped Metal Floors
- Operates On O-31 Curves

40' STEEL SIDED REEFER CAR

- Unit Measures: 11 3/4" x 2 9/16" x 3 1/2"

REEFER CAR

- Unit Measures: 11 5/8" x 2 3/4" x 3 9/16"



Pacific Fruit Express - 40' Steel Sided Reefer Car
20-94088 \$44.95

Reefer Cars



Canadian Pacific - Reefer Car
20-94092 \$44.95



Lehigh Valley - Reefer Car
20-94094 \$44.95



Denver Rio Grande - Reefer Car
20-94093 \$44.95



BAR State Of Maine - Reefer Car
20-94091 \$44.95



Amtrak - Rapid Discharge Car
20-98436 \$44.95



CSX - Rapid Discharge Car
20-98437 \$44.95



Gifford Hill - Rapid Discharge Car
20-98438 \$44.95

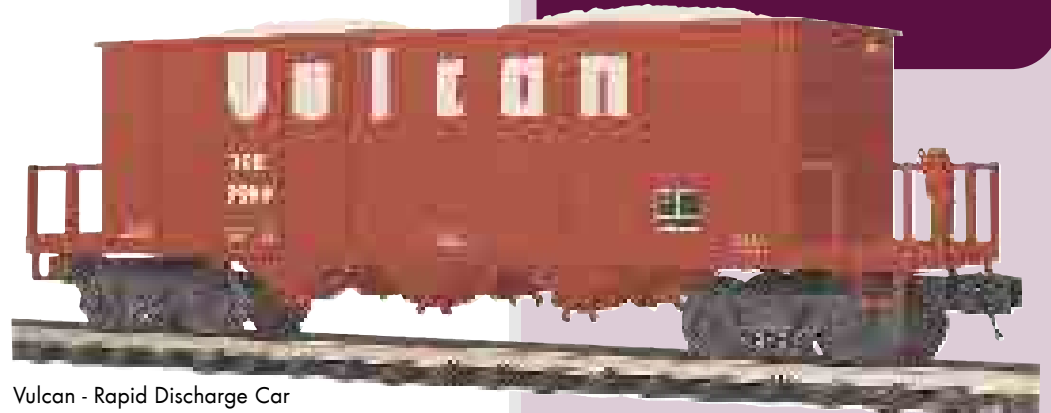

Vulcan - Rapid Discharge Car
20-98439 \$44.95

Maintenance of Way or M.O.W. cars are as important to real railroad operations as locomotives because without track maintenance, the trains can't run. At M.T.H. we've long included various M.O.W. cars so that your railroads right-of-ways will remain trouble-free.

Crane cars and crane tender cars, ballast spreaders and snow plows keep the track worry free and model railroaders looking to complete their miniature version of a real-life railroad need only look to M.T.H.'s Premier Line for these exciting cars. Each of these cars include lighted interiors, detailed yet durable ABS bodies and standard sprung die-cast metal trucks with operating metal couplers.

FEATURES

- Intricately Detailed Durable ABS Body
- Metal Wheels and Axles
- Die-Cast 4-Wheel Trucks
- Operating Die-Cast Metal Couplers
- Colorful, Attractive Paint Schemes
- Separate Metal Handrails
- Fast-Angle Wheel Sets
- Needle-Point Axles
- 1:48 Scale Dimensions
- Unit Measures: 11 1/4" x 2 9/16" x 3 3/8"
- Operates On O-31 Curves

Moving freight has always been the railroad's primary job - whether it be people or objects. When the automobile and trucking industry really began to take off, the railroads suffered from a loss of traffic. But as time passed, it became clear to the transportation industry that the railroad was still an efficient means to move freight.

Today, it's not uncommon to sit at a crossing and see hundreds of flat cars with trailers passing you by. The M.T.H. Premier Line features several scale proportioned truck trailers mounted atop flat cars to capture this vital aspect of freight movement. Choose from 13 different flat cars each equipped with a unique load.

FEATURES

- Intricately Detailed Durable ABS Bodies
- Metal Wheels and Axles
- Die-Cast 4-Wheel Trucks
- Operating Die-Cast Metal Couplers
- Colorful, Attractive Paint Schemes
- Fast-Angle Wheel Sets
- Needle-Point Axles
- Scale Proportioned Loads

FLAT CAR WITH LOAD

- Unit Measures: 14 5/8" x 2 3/4" x 4"
- Operates On O-31 Curves

47' TTX HEAVY DUTY FLAT CAR

- Unit Measures: 16 1/2" x 2 11/16" x 2 1/8"
- Operates On O-42 Curves



Santa Fe - Flat Car - w/Bulkheads & Pipe Load
20-98443 \$44.95



Pennsylvania - Flat Car - w/Bulkheads & Pipe Load
20-98442 \$44.95

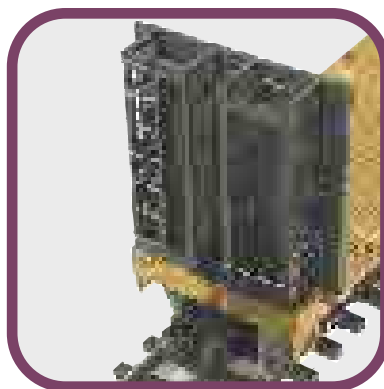

Chicago NorthWestern - Flat Car - w/Bulkheads & Pipe Load
20-98440 \$44.95

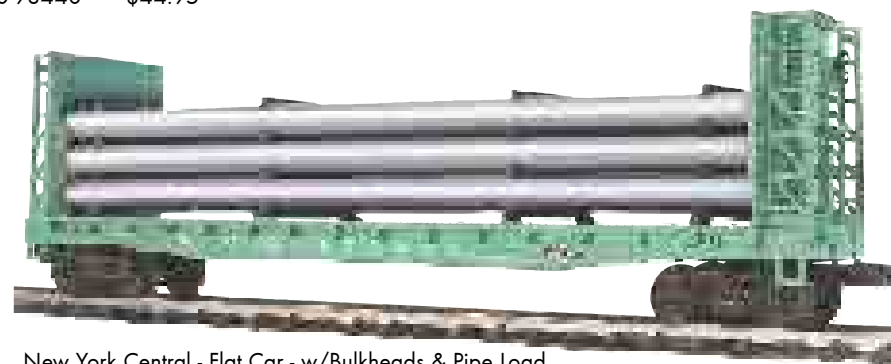
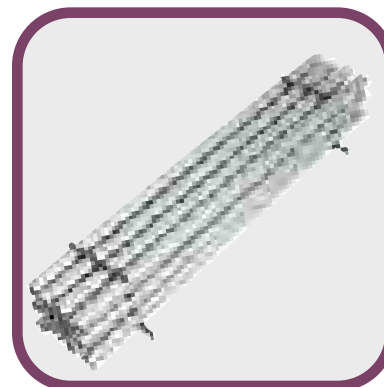

New York Central - Flat Car - w/Bulkheads & Pipe Load
20-98441 \$44.95



TTX - Flat Car w/Telescopic Handler with Bucket
20-98445 \$59.95



John Deere - Flat Car w/(3) 4230 Tractors
20-98426 \$59.95
John Deere is a registered trademark of Deere & Company



TTX - Flat Car w/(2) Dealer Service Trucks
20-98447 \$69.95



TTX - Flat Car w/580B Harvester with HH65 Cutting Head
20-98448 \$59.95

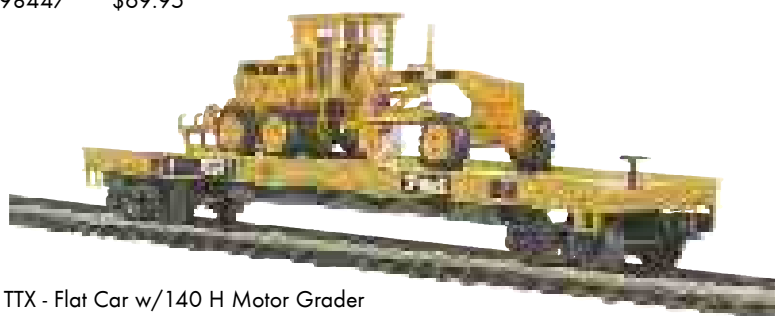

TTX - Flat Car w/140 H Motor Grader
20-98446 \$59.95

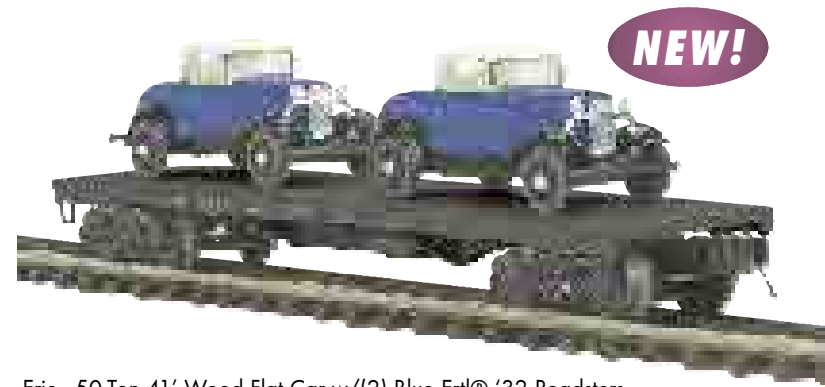
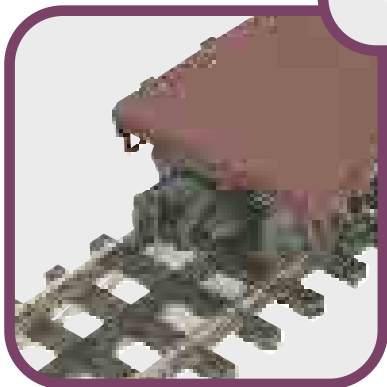

Erie - 50-Ton 41' Wood Flat Car w/(2) Blue Ertl® '32 Roadsters
20-98451 \$54.95

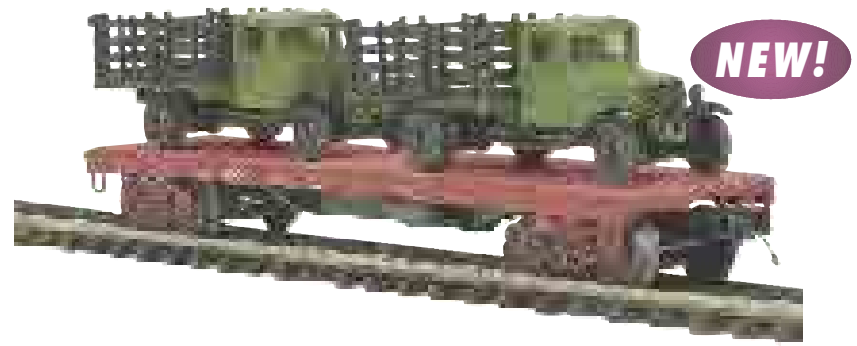

Union Pacific - 50-Ton 41' Wood Flat Car w/(2) Green Ertl® '40 Ford Customs
20-98450 \$54.95



Pennsylvania - 50-Ton 41' Wood Flat Car w/(2) Red Ertl® '32 Roadsters
20-98449 \$54.95

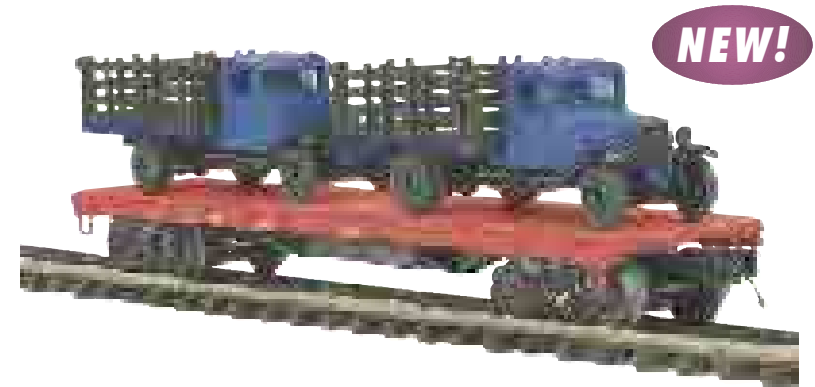

Great Northern - 50-Ton 41' Wood Flat Car w/(2) Blue Ertl® '40 Ford Customs
20-98452 \$54.95

FEATURES

- Intricately Detailed Durable ABS Bodies
- Metal Wheels and Axles
- Die-Cast 4-Wheel Trucks
- Operating Die-Cast Metal Couplers
- Colorful, Attractive Paint Schemes
- Fast-Angle Wheel Sets
- Needle-Point Axles
- Scale Proportioned Loads
- Unit Measures: 11 3/4" x 2 1/2" x 1 1/16"
- Operates On O-31 Curves



NEW!

Western Maryland - 50-Ton 41' Wood Flat Car
20-98454 \$39.95



NEW!

Baltimore & Ohio - 50-Ton 41' Wood Flat Car
20-98453 \$39.95



NEW!

Santa Fe - 50-Ton 41' Wood Flat Car
20-98455 \$39.95



NEW!

New York Central - 50-Ton 41' Wood Flat Car
20-98456 \$39.95

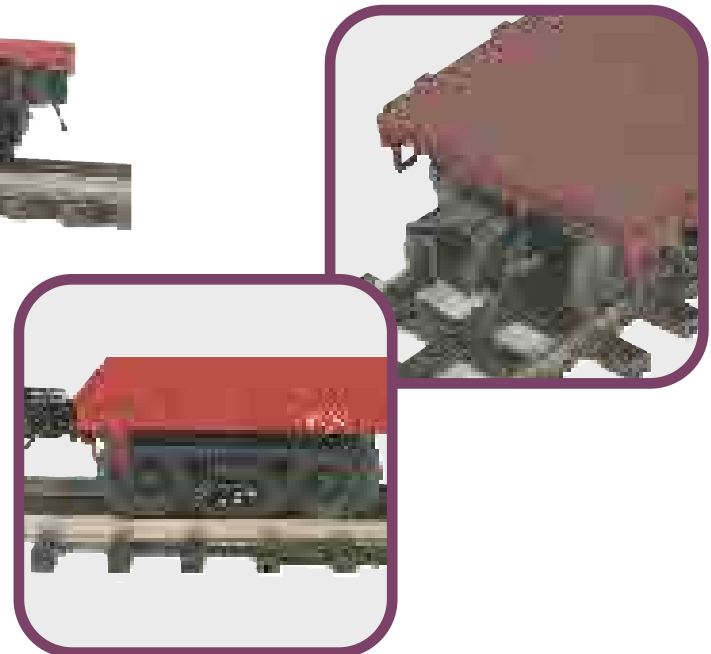



Pittsburgh & Lake Erie - 47' TTX Heavy Duty Flat Car w/Transformer
20-98434 \$59.95



Westinghouse - 47' TTX Heavy Duty Flat Car w/Transformer
20-98435 \$59.95



TTX - 47' TTX Heavy Duty Flat Car w/980G Wheel Loader
20-98431 \$79.95

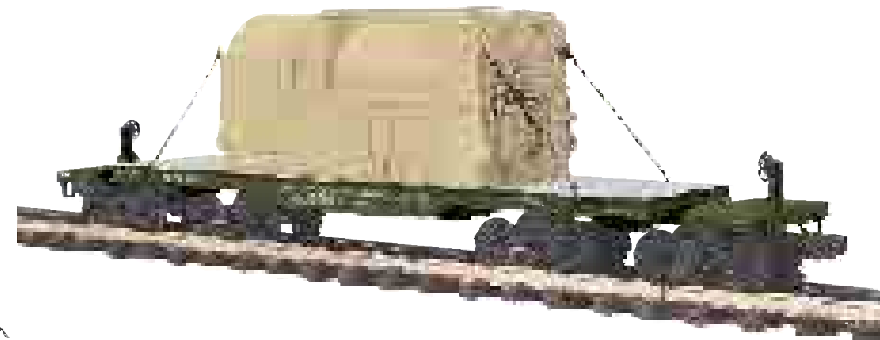

DODX - 47' TTX Heavy Duty Flat Car w/Transformer
20-98432 \$59.95



Milwaukee Road - 47' TTX Heavy Duty Flat Car w/Transformer
20-98433 \$59.95



Northern Pacific - Bay Window Caboose
20-91160 \$54.95

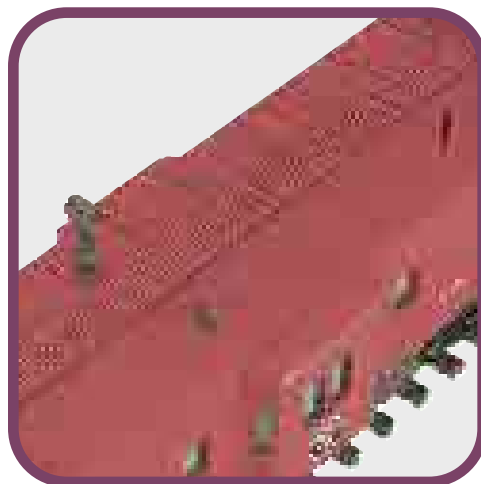

Milwaukee Road - Bay Window Caboose
20-91158 \$54.95



Monon - Bay Window Caboose
20-91157 \$54.95



Minneapolis & St Louis - Bay Window Caboose
20-91159 \$54.95

The caboose is perhaps the most popular of freight cars despite its extinction from modern real-life freight consists. Yet model railroaders continue to make the caboose a fan favorite and have given M.T.H. the incentive to produce six different models since 1996.

An eighth model is debuting in the M.T.H. Premier Line in 2004 along with 16 other schemes in three of our most popular models. M.T.H. fans have long found the Premier Line caboose to be an exceptional value. We even include a brakeman figure inside for an added touch of realism.

FEATURES

- Intricately Detailed Durable ABS Body
- Metal Wheels and Axles
- Die-Cast 4-Wheel Trucks
- Operating Die-Cast Metal Couplers
- Colorful, Attractive Paint Schemes
- Fast-Angle Wheel Sets
- Needle-Point Axles
- 1:48 Scale Dimensions
- Caboose Interiors With Overhead Lighting
- Operating Interior Lighting
- Separate Metal Handrails
- Decorative Brake Wheels
- 1:48 Scale Dimensions

BAY WINDOW CABOOSE

- Unit Measures: 10 7/8" x 2 15/16" x 3 13/16"
- Operates On O-31 Curves

CA-1 WOODSIDED CABOOSE

- Unit Measures: 10 3/8" x 2 1/2" x 3 5/8"
- Operates On O-31 Curves

EXTENDED VISION CABOOSE

- Unit Measures: 10 3/4" x 2 3/4" x 4"
- Operates On O-31 Curves

STEEL CABOOSE

- Unit Measures: 10 1/4" x 2 1/2" x 4 1/4"
- Operates On O-31 Curves

STEEL CABOOSE - CENTER CUPOLA

- Unit Measures: 9 1/8" x 2 7/16" x 3 3/4"
- Operates On O-31 Curves

Caboose



New Haven - CA-1 Woodsided Caboose
20-91162 \$54.95



Union Pacific - CA-1 Woodsided Caboose
20-91161 \$54.95



Long Island - CA-1 Woodsided Caboose
20-91163 \$54.95



New York Central - CA-1 Woodsided Caboose
20-91164 \$54.95



CP Rail - Extended Vision Caboose
20-91165 \$54.95



Chessie - Extended Vision Caboose
20-91166 \$54.95



Pennsylvania - Extended Vision Caboose
20-91168 \$54.95



Chicago NorthWestern - Extended Vision Caboose
20-91167 \$54.95





Baltimore & Ohio - Steel Caboose
20-91169 \$54.95



Denver & Rio Grande - Steel Caboose
20-91170 \$54.95



Rutland - Steel Caboose
20-91171 \$54.95



Santa Fe - Steel Caboose
20-91172 \$54.95





Chesapeake & Ohio - Steel Caboose - Center Cupola
20-91173 \$54.95



New York Central - Steel Caboose - Center Cupola
20-91174 \$54.95



Reading - Steel Caboose - Center Cupola
20-91175 \$54.95



Southern - Steel Caboose - Center Cupola
20-91176 \$54.95

MTH Premier O Scale freight car sets are the perfect complement to many of the locomotives featured earlier in this catalog. They also go great with any manufacturer's scale proportioned O Gauge locomotives.

Each car in these sets is individually numbered for authentic realism. And, each set is available in two item numbers. The second item number features an entirely different set of 6 cars, each also individually numbered, allowing you to obtain a total of 12 different numbered cars if desired. When you prefer the convenience of a ready-to-run unit train, M.T.H. Premier Line 6-car sets are a great choice.



John Deere - 3-Car AAR Box Car Set
20-90169 \$149.95

John Deere is a registered trademark of Deere & Company

THIRD SET IN A SERIES

Pittsburgh & Lake Erie - 4-Bay Hopper 6 Car Set
20-90214 \$229.95
Car Numbers 80702, 80704, 80712, 80716, 80720, 80717
20-90215 \$229.95
Car Numbers 80706, 80708, 80718, 80721, 80722, 80729

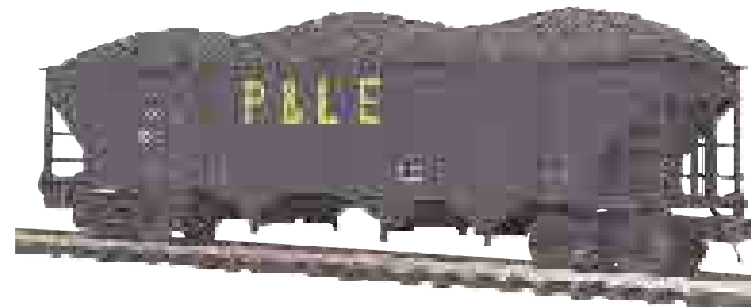

Columbia Oil - 6-Car Modern Tank Car Set
20-90212 \$229.95
Car Numbers 210434, 210436, 210431, 210438, 210435, 210437
20-90213 \$229.95
Car Numbers 210466, 210461, 210467, 210464, 210460, 210468



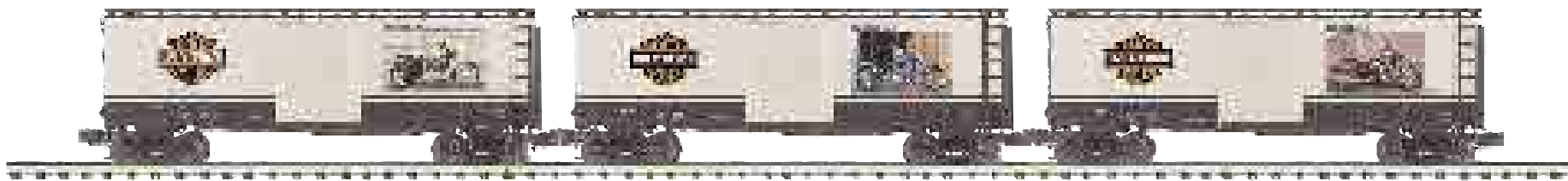

Harley-Davidson® - 3-Car Box Car Set
20-90173 \$149.95

FIRST SET IN A SERIES



Harley-Davidson® Goods, Registered Trademark of H-D Michigan, Inc.
© H-D®. All Rights Reserved.



FEATURES

- Metal Wheels and Axles
- Die-Cast 4-Wheel Trucks
- Operating Die-Cast Metal Couplers
- Colorful, Attractive Paint Schemes
- Fast-Angle Wheel Sets
- Needle-Point Axles
- Separate Metal Handrails
- Decorative Brake Wheels
- Intricately Detailed Durable ABS Bodies
- 1:48 Scale Dimensions
- Operates On O-31 Curves



New York Central - 6-Car Double Door 50' Box Car Set

20-90206 \$229.95

Car Numbers 65610, 65608, 65604, 65612, 65624, 65628

20-90207 \$229.95

Car Numbers 65614, 65618, 65632, 65626, 65630, 65621



HOPPER SET FEATURES

- Intricately Detailed Durable ABS Body
- Metal Wheels and Axles
- Die-Cast 4-Wheel Trucks
- Operating Die-Cast Metal Couplers
- Colorful, Attractive Paint Schemes
- Separate Metal Handrails
- Fast-Angle Wheel Sets
- Needle-Point Axles
- 1:48 Scale Dimensions
- Operates On O-31 Curves

Amtrak - 6-Car Rapid Discharge Hopper Set

20-90208 \$229.95

Car Numbers 11568, 11566, 11565, 11563, 11572, 11564

20-90209 \$229.95

Car Numbers 11573, 11575, 11567, 11568, 11570, 11578

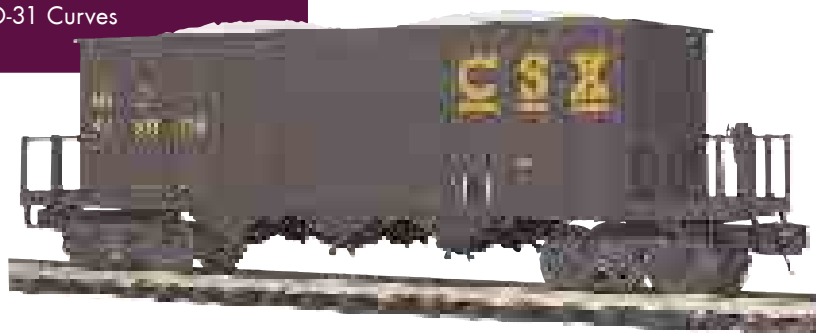

CSX - 6-Car Rapid Discharge Hopper Set

20-90210 \$229.95

Car Numbers 293020, 293021, 293023, 293025, 293027, 293029

20-90211 \$229.95

Car Numbers 293035, 293037, 293045, 293053, 293039, 293034

Pennsylvania - 6-Car 40' AAR Box Car Set

20-90198 \$229.95

Car Numbers 6202, 6208, 6210, 6212, 6214, 6220

20-90199 \$229.95

Car Numbers 6204, 6205, 6213, 6211, 6222, 6225

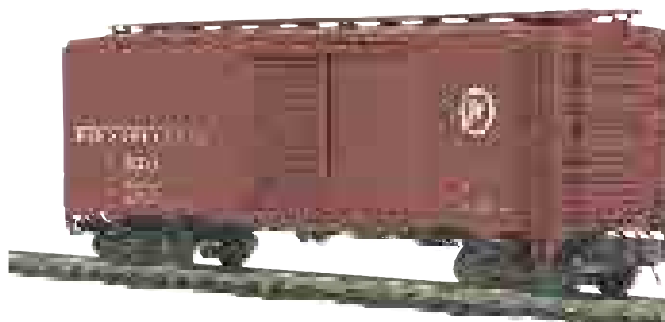

NEW!





Santa Fe - 6-Car 40' AAR Box Car Set

20-90200 \$229.95
 Car Numbers 143530, 143538, 143532, 143542, 143546, 143552
 20-90201 \$229.95
 Car Numbers 143510, 143514, 143520, 143526, 143522, 143528

NEW!



BOX CAR FEATURES

- Metal Wheels and Axles
- Die-Cast 4-Wheel Trucks
- Operating Die-Cast Metal Couplers
- Colorful, Attractive Paint Schemes
- Fast-Angle Wheel Sets
- Needle-Point Axles
- Separate Metal Handrails
- Decorative Brake Wheels
- Intricately Detailed Durable ABS Bodies
- Sliding Car Doors
- 1:48 Scale Dimensions
- Operates On O-31 Curves



Union Pacific - 6-Car 40' AAR Box Car Set

20-90202 \$229.95
 Car Numbers 184000, 184004, 184006, 184011, 184014, 184026
 20-90203 \$229.95
 Car Numbers 185054, 185042, 185044, 185050, 185056, 185062

NEW!

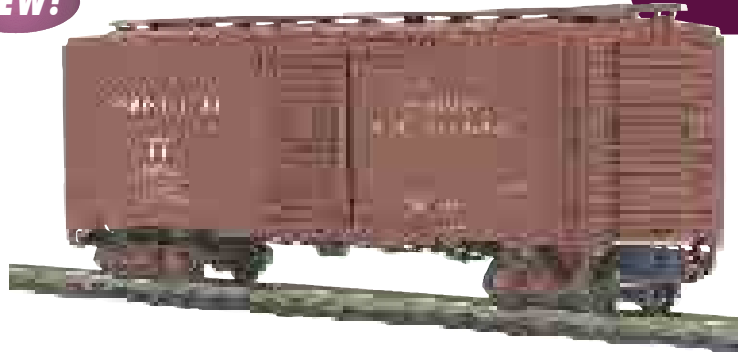

Western Maryland - 6-Car 40' AAR Box Car Set

20-90204 \$229.95
 Car Numbers 28802, 28808, 28807, 28812, 28816, 28815
 20-90205 \$229.95
 Car Numbers 28803, 28806, 28805, 28810, 28814, 28811

NEW!





Railway Express Agency - 6-Car 40' Steel Sided Reefer Set
 20-90222 \$229.95
 Car Numbers 6617, 6621, 6635, 6629, 6625, 6633
 20-90223 \$229.95
 Car Numbers 6635, 6615, 6637, 6639, 6643, 6645



Pacific Fruit Express - 6-Car 40' Steel Sided Reefer Set
 20-90218 \$229.95
 Car Numbers 46704, 46713, 46707, 46715, 46718, 46708
 20-90219 \$229.95
 Car Numbers 46720, 46722, 46725, 46719, 46728, 46727



American Transit Refrigerator Transit Co. - 6-Car 40' Steel Sided Reefer Set
 20-90220 \$229.95
 Car Numbers 32042, 32045, 32040, 32046, 32048, 32044
 20-90221 \$229.95
 Car Numbers 32050, 32052, 32054, 32062, 32058, 32053





Santa Fe - 6-Car 40' Steel Sided Reefer Set

20-90216 \$229.95

Car Numbers 3530, 3542, 3534, 3538, 3536, 3534

20-90217 \$229.95

Car Numbers 3544, 3546, 3552, 3540, 3548, 3546



FEATURES

- Metal Wheels and Axles
- Die-Cast 4-Wheel Trucks
- Operating Die-Cast Metal Couplers
- Colorful, Attractive Paint Schemes
- Fast-Angle Wheel Sets
- Needle-Point Axles
- Separate Metal Handrails
- Decorative Brake Wheels
- Intricately Detailed Durable ABS Bodies
- 1:48 Scale Dimensions



Agar Packing Co. - 6-Car 40' Steel Sided Reefer Set

20-90224 \$229.95

Car Numbers 370, 372, 373, 378, 375, 379

20-90225 \$229.95

Car Numbers 374, 376, 380, 385, 388, 391

Premier Line Passenger Cars are available in several popular style bodies that are sure to match whatever era you model. Configured in 5-car, 4-car, 2-car and single-car configurations, each prototype features car interior detail, overhead interior lighting, end-of-car diaphragms and intricate under-car detail. All configurations are mounted atop die-cast metal 4 or 6-wheel trucks with operating metal couplers, metal wheels and metal axles.

Designed to bring authenticity and smooth performing operation to any O Gauge layout, modelers will find no finer O Gauge value than Premier Line Passenger Cars.

FEATURES

- Durable ABS Intricately Detailed Bodies
- Metal Wheels and Axles
- Overhead Interior Lighting
- Die-Cast 6-Wheel Trucks
- Operating Die-Cast Metal Couplers
- Colorful, Attractive Paint Schemes
- End-of-Car Diaphragms
- Separate Metal Handrails
- Fast-Angle Wheel Sets
- Needle-Point Axles
- Detailed Car Interiors
- 1:48 Scale Dimensions
- Sliding Baggage Car Doors
- Detailed Car Undercarriage
- Operates On O-42 Curves

5-Car Sets Feature: (1) Baggage, (2) Coaches, (1) Vista Dome, (1) Observation or (1) Baggage, (3) Coaches, (1) Observation
 • Unit Measures: 90 5/8" x 2 1/2" x 3 5/8"

2-Car Sets Feature (1) Combine, (1) Diner
 • Unit Measures: 36 1/4" x 2 1/2" x 3 5/8"

• Individual Cars Measure: 18 1/4" x 2 1/2" x 3 5/8"



Boston & Albany
 5-Car 70' Madison Passenger Set
 20-4069 \$399.95
 2-Car 70' Madison Comb/Din Passenger Set
 20-4169 \$159.95
 70' Madison RPO Passenger Car
 20-4269 \$69.95



**PASSENGER
 FIGURES
 INCLUDED**



Boston & Albany - 70' Madison Baggage Car
 20-4369 \$69.95



Great Northern
 5-Car 70' Madison Passenger Set
 20-4070 \$299.95
 2-Car 70' Madison Comb/Din Passenger Set
 20-4170 \$129.95



Great Northern - 70' Madison RPO Passenger Car
 20-4270 \$69.95

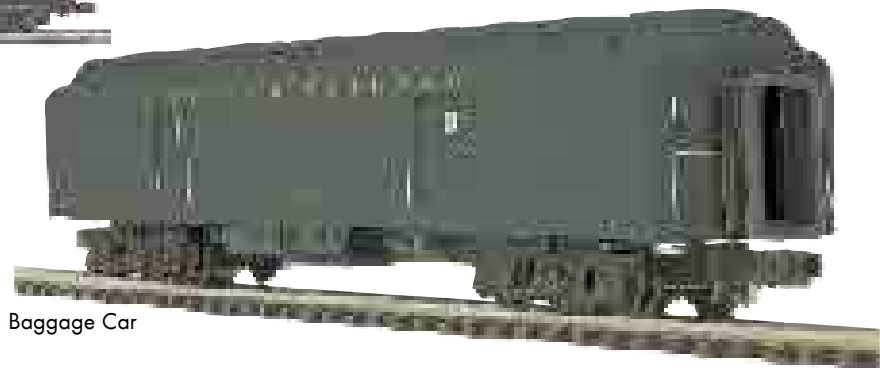

Great Northern - 70' Madison Baggage Car
 20-4370 \$69.95

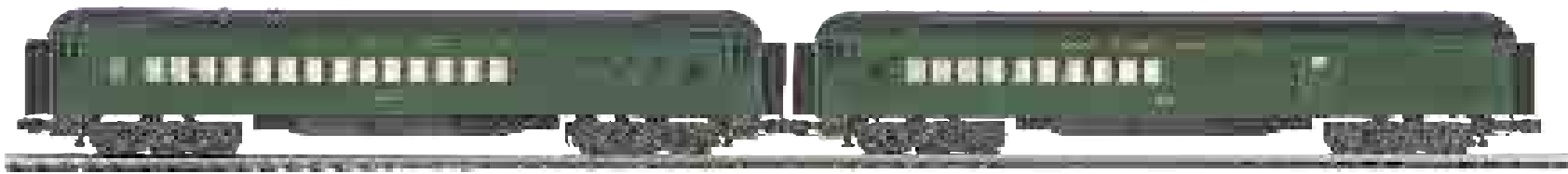

New York Central
 2-Car 70' Madison Comb/Din Passenger Set
 20-4171 \$159.95
 70' Madison RPO Passenger Car
 20-4271 \$69.95

**PASSENGER
 FIGURES
 INCLUDED**



New York Central - 70' Madison Baggage Car
 20-4371 \$69.95



New York Central - 5-Car 70' Madison Passenger Set
 20-4071 \$399.95



Santa Fe - 70' Madison RPO Passenger Car
 20-4261 \$69.95

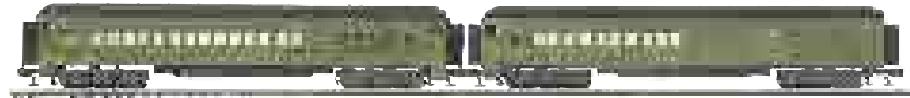

Santa Fe -2-Car 70' Madison Comb/Din Passenger Set
 20-4161 \$129.95



Santa Fe - 70' Madison Baggage Car
 20-4361 \$69.95

Santa Fe - 5-Car 70' Madison Passenger Set
 20-4061 \$299.95



Strasburg Railroad
 5-Car 70' Madison Passenger Set
 20-4072 \$399.95
 2-Car 70' Madison Comb/Din Passenger Set
 20-4172 \$159.95
 70' Madison RPO Passenger Car
 20-4272 \$69.95
 70' Madison Baggage Car
 20-4372 \$69.95

**PASSENGER
 FIGURES
 INCLUDED**

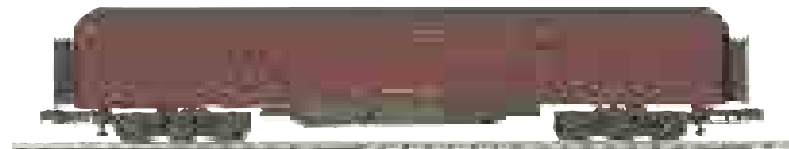



Chesapeake & Ohio
 5-Car 70' ABS Passenger Set - Ribbed
 20-65063 \$399.95
 2-Car 70' ABS Slpr/Diner Passenger Set - Ribbed
 20-66063 \$159.95



**PASSENGER
 FIGURES
 INCLUDED**

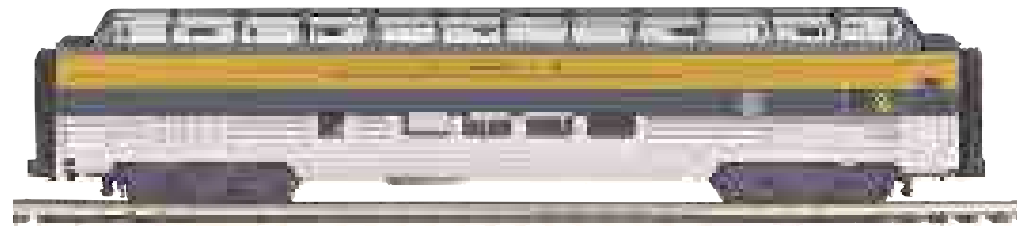

Chesapeake & Ohio - 70' ABS Full Length Vista Dome Passenger Car - Ribbed
 20-67063 \$79.95



**PASSENGER
 FIGURES
 INCLUDED**

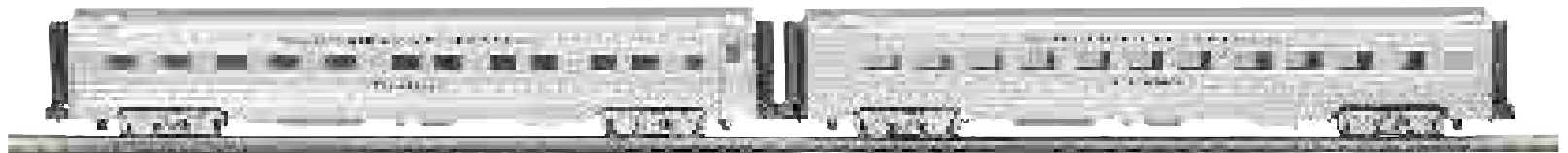

Florida East Coast - 70' ABS Full Length Vista Dome Passenger Car - Ribbed
 20-67064 \$79.95

Florida East Coast
 5-Car 70' ABS Passenger Set - Ribbed
 20-65064 \$399.95
 2-Car 70' ABS Slpr/Diner Passenger Set - Ribbed
 20-66064 \$159.95



Louisville & Nashville
 5-Car 70' ABS Passenger Set - Ribbed
 20-65065 \$399.95
 70' ABS Full Length Vista Dome Passenger Car - Ribbed
 20-67065 \$79.95



**PASSENGER
 FIGURES
 INCLUDED**

FEATURES

- Durable ABS Intricately Detailed Bodies
- Metal Wheels and Axles
- Overhead Interior Lighting
- Die-Cast 4-Wheel Trucks
- Operating Die-Cast Metal Couplers
- Colorful, Attractive Paint Schemes
- End-of-Car Diaphragms
- Separate Metal Handrails
- Fast-Angle Wheel Sets
- Needle-Point Axles
- Detailed Car Interiors
- 1:48 Scale Dimensions
- Detailed Car Undercarriage
- Sliding Baggage Car Doors
- Operates On O-42 Curves



Louisville & Nashville - 2-Car 70' ABS Slpr/Diner Passenger Set - Ribbed
 20-66065 \$159.95

**ALL NEW
 FOUR
 WHEEL
 TRUCKS**



5-Car Sets Feature: (1) Baggage, (2) Coaches, (1) Vista Dome, (1) Observation
 • Unit Measures: 95" x 2 7/16" x 3 1/2"

2-Car Sets Feature: (1) Sleeper, (1) Diner
 • Unit Measures: 38" x 2 7/16" x 3 1/2"

• Vista Dome Unit Measures: 19" x 2 7/16" x 3 1/2"



Santa Fe
 5-Car 70' ABS Passenger Set - Ribbed
 20-65066 \$399.95
 2-Car 70' ABS Slpr/Diner Passenger Set - Ribbed
 20-66066 \$159.95
 70' ABS Full Length Vista Dome Passenger Car - Ribbed
 20-67066 \$79.95



**PASSENGER
 FIGURES
 INCLUDED**

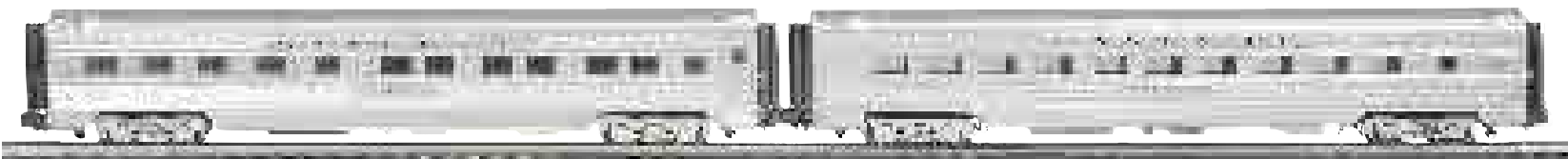

While the power pack that comes with every RailKing® Ready-To-Run set provides plenty of power to operate your set & several additional cars, you'll find as you add more track, cars, & accessories to your layout that you need more power to keep everything running. Fortunately, RailKing has you covered. If you want to power up gradually, you can purchase additional 50-watt Z-500®, 75-watt Z-750® & Z-1000™ transformers as the need arises. Each of these will power a single train on its own loop of track or a few operating accessories.

If you want to max out your power potential, the 400-watt Z-4000® is the most powerful transformer to receive the UL-listing for the model railroading hobby. The Z-4000 has

two separate throttles to let you power two different tracks, & it has two fixed power outputs you can use for operating accessories. A single Z-4000 will power a lot of layout.

Remote Control

The RailKing remote control provided in your Ready-To-Run set gives you the option to move around the room while you run your train. However, as you compile more trains, more track, & begin more advanced operations, you might find yourself looking for a more sophisticated remote control system. M.T.H. offers two to choose from:

The Z-4000 Remote Control System: designed to work with

the 400-watt Z-4000 transformer, this remote can control up to 3 Z-4000s at a time, for a total of 6 loops of track, all from one handheld. The LED screen makes it easy to keep an eye on your track voltage.

The DCS Remote Control System: the ultimate in control, the DCS system gives you individual control of each Proto-Sound® 2.0 engine on your layout & gives you access to literally hundreds of new & exciting features & engine settings. Add the optional AIU & you can control each accessory & switch from the same remote control.

Whatever option you choose, let M.T.H. & RailKing put you in charge of your empire.

Why the U.L. Listing?

M.T.H. Electric Trains is committed to manufacturing safe, U.L. approved transformers & power supplies. By subjecting our transformers to the strenuous tests & requirements of the U.L. laboratories, M.T.H. helps ensure that these products meet the same requirements as other consumer electronics sold today. When choosing a new transformer, model railroaders should only look for those that have received a U.L. listing.



For the operator on a budget, the Z-500 & Z-750, packing 50-75 watts of power, are excellent power choices for small & medium sized layouts or for anyone looking to power model railroading accessories. Featuring a U.L. approved design, both the Z-500 & Z-750 utilize a transformer & a separate controller which contains bell, horn & direction buttons that can control any manufacturer's locomotives & sound systems including Proto-Sound® equipped steam, diesel & electric locomotives.



Z-500 Transformer
Item No. 40-500
\$49.95

Inexpensive Way to Power Extra Accessories



Z-750 Transformer
Item No. 40-750
\$79.95

- Z-500 & Z-750 Transformer Features**
- U.L. Approved
 - 50 or 75 Watts Max Power Output
 - Controller LED On Light
 - Smooth Operating Throttle Knob
 - Built-In Circuit Breaker Protection
 - Individual Bell, Horn and Direction Buttons

The most powerful Ready-to-Run train set transformer you can find, the Z-1000 boasts 100 watts of power, a U.L. approved design & separate 14v Accessory Ports. Its robust design will provide years of service & power enough for any starter set to a moderate size layout. Available in many RailKing starter sets or separately, the Z-1000 is the perfect solution for a growing O Gauge layout.

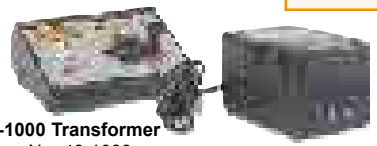

Z-1000 Transformer
Item No. 40-1000
\$99.95

Includes 14v Accessory Ports



RailKing Controller Set
Item No. 40-750C
\$39.95

- Z-1000 Transformer Features**
- U.L. Approved
 - 100 Watts Max Power Output
 - Controller LED On Light
 - Smooth Operating Throttle Knob
 - Built-In Circuit Breaker Protection
 - Individual Bell, Horn & Direction Buttons
 - 14v Accessory Port

Operators of any O, S, or Standard Gauge locomotive, regardless of manufacturer, will appreciate the power & control features found in the 400-Watt Z-4000 transformer - the only U.L. Approved 400-Watt RMS transformer available today. The transformer's control panel has a voltage display, amperage display, & horn, bell, direction, & programming buttons for two track outputs. Two additional fixed voltage outputs are also available, making the Z-4000 the perfect choice for operating locomotives & accessories.



400 Watts!
Most Powerful U.L. Listed Train Transformer

Z-4000 Transformer
Item No. 40-4000
\$399.95

Perhaps the most exciting feature of the Z-4000 is its microprocessor controlled operating system. There is actually a powerful computerized brain that makes the Z-4000 highly upgradeable. In fact, the Z-4000 has been designed so that add-ons like a walk-around throttle system will be easy & quick to install & use. This product has earned the UL listing mark.

- Z-4000 Transformer Features**
- UL Listed To US & Canadian Safety Standards
 - Pure Sine Wave Power Signal
 - (2) 21v Variable Track Outputs
 - (1) 14v Fixed-Voltage Output
 - (1) 10v Fixed-Voltage Output
 - Internal Cooling Fan
 - On/Off Power Switch
 - Expansion Port for Z-4000 Remote Control System
 - Compatible As Power Source For All O Gauge AC-Powered Locomotives
 - (2) Voltage LED Displays
 - (2) Amperage LED Displays
 - Resettable Circuit Breakers for Each Output
 - Large Red LED Overload Indicator
 - Large Green LED Power On Indicator
 - Measures: 8 3/4" (H), 11 1/8" (D), 14 3/4" (W)

Z-4000 Remote System

Puts 400 watts of power in the palm of your hand! Access conventional Proto-Sound features from anywhere on your layout. 900 MHz remote controls up to three Z-4000 transformers & six loops of track. Requires Z-4000 transformer.

Z-4000 Remote System Features

- 1 Z-4000 Remote Control
- 1 Remote Receiver

Range:
Approximately 30 feet

Z-4000 Remote Control System
Item No. 40-4001.....\$79.95

Z-4000 Remote Control Receiver
Item No. 40-4002.....\$39.95

DCS Compatible

RailKing Remote System

Infrared remote control gives you freedom to move around while still controlling your train. Designed for use with Z-500 or Z-750 transformers.

RailKing Remote Control System
Item No. 50-1012.....\$59.95

RailKing Remote Control
Item No. 50-1011.....\$39.95

RailKing Remote Lock-On
Item No. 50-1013.....\$29.95

Play Music Through any Loco-Sound® Engine

System Includes:
1 Remote Control
1 Remote Lock-On

Range:
Approximately 15 feet



There is a new way of controlling model railroads today that you've got to see to believe. It's called DCS (for Digital Command System) & it's the most revolutionary product to hit model railroading since locomotives first became equipped with sound!

Unlike traditional or conventional means of operating a model railroad, command systems allow the user to independently control each engine even if other engines are on the same track at the same time. The concept has been around since the early 1990s, but only DCS makes it simple & easy to use thanks to its state-of-the-art technology & intuitive interface.

The DCS Remote Control System allows you to leave track voltage constant and control multiple Proto-Sound® 2.0 equipped engines individually. Thirty-two buttons & an LCD display provide total control over Proto-Sound® 2.0 features such as setting scale mph, passenger station announcements, & setting multi-unit lash-ups, etc.

A single DCS Remote handheld will allow you to control Proto-Sound® 2.0 locomotives in command mode, TMCC equipped engines in command mode (when you connect a Lionel Command Base to the TIU) & all conventional 3-rail O Gauge engines at the same time.



Once wired up you are ready to run! Thanks to the simplicity of the DCS remote control's intuitive interface. You'll need to "add" your engines into the remote. There are no names, numbers or complicated commands, the DCS remote does most of the work for you!



1 Go to the engine set up menu



2 Choose your engine choice*

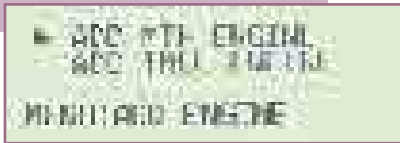

3 DCS will go out & "look" for Proto-Sound® 2.0 command equipped engines on your layout. When it finds one, it adds it into the remote & tells you when it is done.

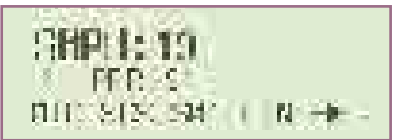

* TMCC operation requires a TMCC command base & DCS TIU/TMCC cable. (item # 50-1018)



1 Press the TR button & select the variable track you wish to control



2 Use the thumbwheel to raise & lower the track voltage

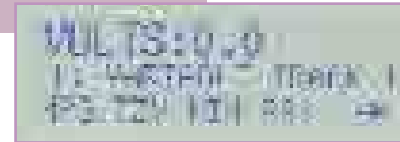

3 Use the Engine button & the TR button to jump between command & conventional control

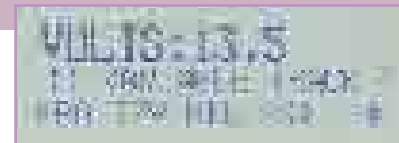

*Only PS2 and conventional engines can be simultaneously operated.

Must See!



Video Guide To DCS - VHS
60-1190 \$19.95



Video Guide To DCS - DVD
60-1191 \$19.95

MAX YOUR POWER

DCS features two components, the DCS Remote Control & the Track Interface Unit (TIU). An additional component, the Accessory Interface Unit (AIU), can be added to give you control over accessories & switches. In addition, you will need an AC transformer.

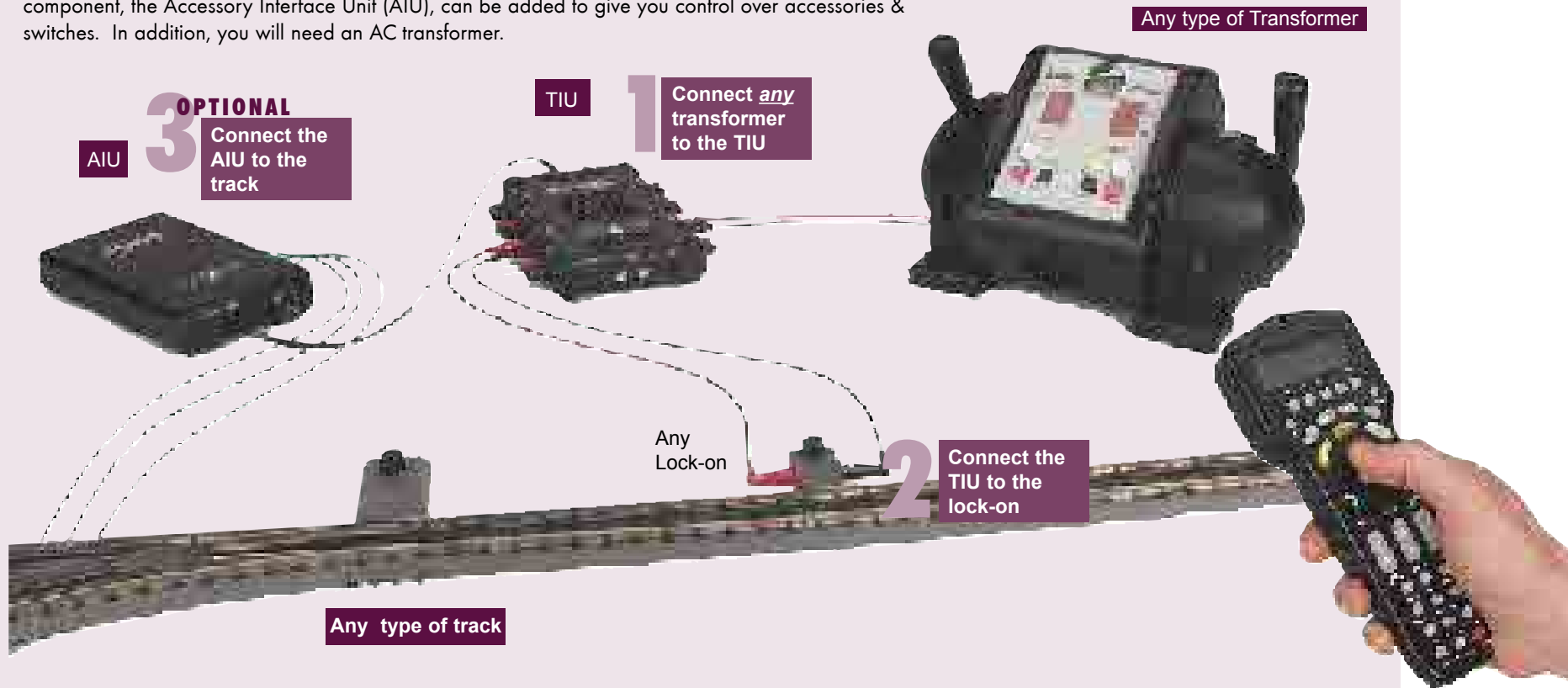

DCS works by transmitting an electric "digital" signal along with the power from the transformer into your railroad's track. In order to get that signal to the track, you must plug your transformer into the TIU & then attach the TIU to the track. Special banana jacks make the wiring a snap. The DCS remote control "talks" to the TIU via a radio signal so there's nothing to hook up here except the installation of four AAA batteries.

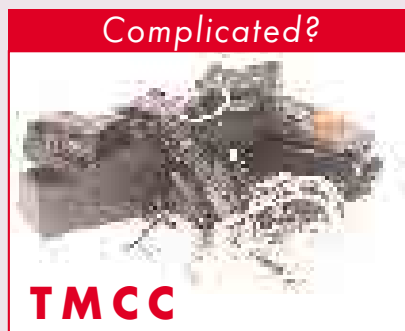

All these TMCC components are required to achieve similar features as those found in DCS.

Unmatched command control features

Operational Features

- 9 Independent Volume Control Settings
- 16 Adjustable Chuff Rate Settings
- 3 Adjustable Smoke Intensity Settings
- Adjustable Brake Sound Effects
- Adjustable Wheel "Clicky-Clack" Sounds
- 15 Programmable Custom Sounds
- 4 Adjustable Diesel Engine Ditch Lighting Effects
- 120 Adjustable Maximum Engine Speed Settings
- 3 Adjustable Locomotive Direction Start-up Engines
- Programmable Lash-up Creation
- Programmable Route Creation
- Programmable Scene Creation
- Record/Playback 90 Minutes of Operation
- Downloadable Locomotive Sounds Sets
- Independent Locomotive Chronometer
- Independent Locomotive Odometer
- Independent Locomotive Trip Odometer
- Independent Locomotive Battery Charge
- Track Signal Test
- Linear Track Length Meter
- Adjustable 50 or 60Hz AC Input
- 2 Independent Engine Reset Features
- 16 TIU Individual Channel Controls

Remote Control Features

- Built-in Microphone
- Back Lit 4-Line LCD Screen
- 5 Programmable Softkeys with Up to 36 Options
- Controls Between 4 & 20 Tracks
- Controls Between 20 & 500 Accessories
- Independent Whistle & Bell Sounds
- 120 Speed Steps
- On-Screen List of Up to 99 Engines
- 42 Levels of Programming Option
- Labor/Drift Chuffing Sound Control
- Diesel Rev Up/Down Sound Control
- Speed Boost & Brake Control
- One Touch Smoke On/Off Control
- One Touch Volume Level Control
- Engine Sounds Mute Button
- One Touch Headlight On/Off Control
- One Touch Proto-Cast™ Control
- One Touch Coupler Operation Control
- One Touch Engine Startup Control
- One Touch Engine Shutdown Control
- One Touch Passenger or Freight Sound Activation
- One Touch Doppler Sound Effect Operation
- Stores Up to 99 different Engines
- One Touch Emergency Stop Button
- Adjustable Acceleration/Deceleration Rates
- Built-in Programming Port for Future Software Upgrades

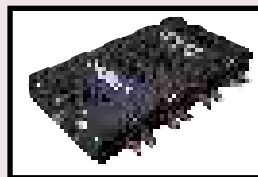

DCS Track Interface Unit (TIU)
50-1003 \$179.95

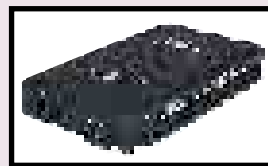

DCS Accessory Interface Unit (AIU)
50-1004 \$99.95

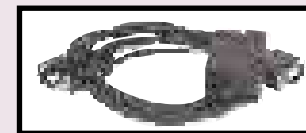

TIU/TMCC 6' Connector Cable
50-1018 \$19.95

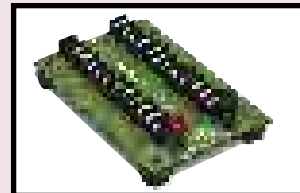

12-Port Terminal Block
50-1014 \$16.95

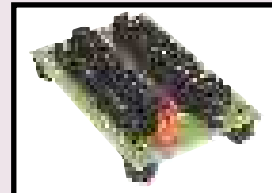

24-Port Terminal Block
50-1020 \$29.95



Proto-Cast/Programming 6' Mini-to-Mini Cable
50-1009 \$9.95

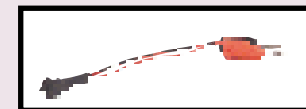

TIU/Barrel Jack Adapter Cable
50-1017 \$9.95



DCS Remote Control - Handheld Unit
50-1002 \$149.95

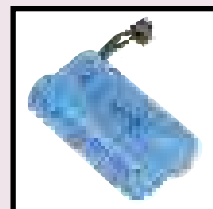

AA NiCad Proto-Sound Battery
50-1024 \$9.95



Proto-Sound® Battery
50-1008 \$9.95



Proto-Sound® 2.0 Battery Charger
50-1019 \$14.95



DCS Remote Control System
50-1001 \$299.95

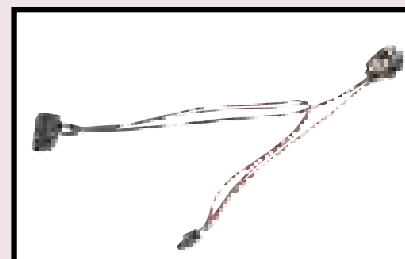

Proto-Sound® Locomotive External Battery Charger Kit
50-1021 \$9.95

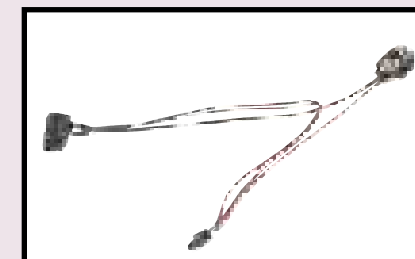

Proto-Sound® 2.0 Locomotive External Battery Charger Kit
50-1022 \$9.95

Every model train layout needs a track system before anything can really happen. Choosing a track system doesn't have to be complicated if simplicity, good looks and a wide variety of choices are your criteria.

M.T.H. Electric Trains has developed two track systems: ScaleTrax™ and RealTrax® for O Gauge model railroaders. Both systems feature solid nickel-silver rails that won't rust or bend when stepped on. Both systems utilize a patented quick-connect connection system that doesn't require track pins or rail joiners. Most importantly, both systems are fully compatible with any manufacturer's O Gauge locomotives or rolling stock and each features a wide variety of components for virtually every possible track design.

If you're a scale modeler who wants a highly realistic looking track system, ScaleTrax just might be the choice for you. Featuring a lower track rail profile than other track systems and a nearly invisible center rail, ScaleTrax is the best choice to make your scale layout look incredibly realistic.

Traditional O Gaugers will find RealTrax a simple, easy-to-use solution perfect for permanent or temporary layouts. Thanks to its built-in roadbed, RealTrax makes a great solution for a carpet layout. Its snap together design makes setting up and taking down a temporary layout a breeze for railroaders of any age.

FEATURES

- Solid, Rust-Proof Nickel Silver Track Rails
- Requires No Connecting Pins or Rail Joiners
- Authentic Molded Realistic Roadbed
- Assemble RealTrax in Minutes Without Any Special Tools
- Flexible Enough To Set-Up Virtually Anywhere, Even on Carpet
- Easy To Power, Plug-In Lighted Lockon Ports On Every Track Section
- Available In Different Lengths & Curves, Switches & Operating Track Sections For Easy Expandability
- Reliable Remote Controlled Operating Switches
- Mates With Other Track Systems
- Works With Any Manufacturers Trains

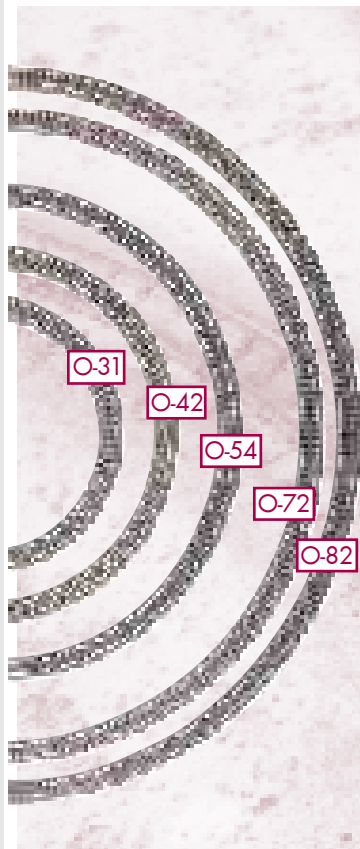

The basic O Gauge track curve is O-31, meaning those curves have a 31" diameter when assembled in a circle (this is the curve size in RailKing sets). For people with more space & larger engines, we offer a series of larger curve sizes, up to O-82, which is 82 inches in diameter. Long engines & cars cannot make a tight curve (think of the way an 18-wheel truck has to swing out wide to make a sharp turn) & often require a large track curve.



Easy Snap Together & Expandable



Flexible Enough To Set-up Virtually Anywhere. Even on Carpet.

Straight Track Sections

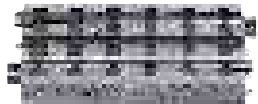

Real-Trax-5" Straight Track
40-1016 \$3.50



Real-Trax-10" Straight Track
40-1001 \$3.50

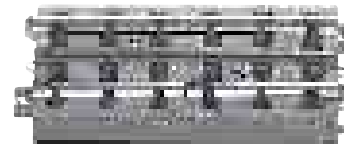

Real-Trax-10" Insulated Straight Track
40-1029 \$7.99

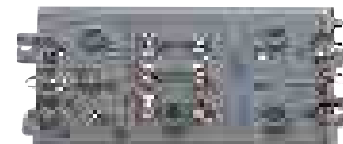

Real-Trax-30" Straight Track Section
40-1019 \$9.95

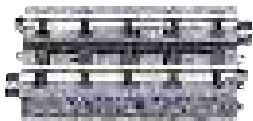

Real-Trax-4.25" Straight Track
40-1017 \$3.50



Real-Trax-3.5" Straight Track
40-1018 \$3.50



RealTrax - 10" Ground Track
40-1068-2 \$7.99



Real-Trax-5.5" Track Section
40-1012 \$3.50



It takes EIGHT O-31 CURVES to make a circle.
It takes TWELVE 42 CURVES to make a circle.
It takes TWELVE 54 CURVES to make a circle.
It takes SIXTEEN O-72 CURVES to make a circle.
It takes SIXTEEN O-82 CURVES to make a circle.

Curved Track Sections



O-72 Curved Track Section
40-1010 \$4.99

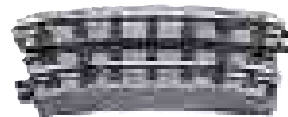

O-72 Half Curved Track Section
40-1049 \$4.99

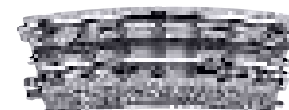

O-31 Half Curved Track Section
40-1022 \$3.50



O-82 Curved Track Section
40-1082 \$4.99



O-31 Curved Track Section
40-1002 \$3.50

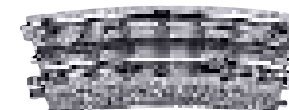

O-42 Half Curved Track Section
40-1045 \$3.99



O-54 Curved Track Section
40-1054 \$4.99



O-42 Curved Track Section
40-1042 \$3.99

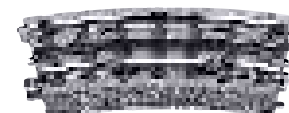

O-54 Half Curved Track Section
40-1057 \$4.99

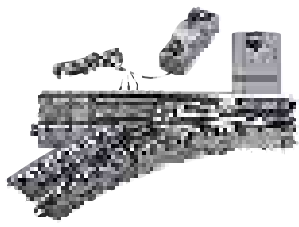

O-31 Switch (LH)
40-1005 \$49.95

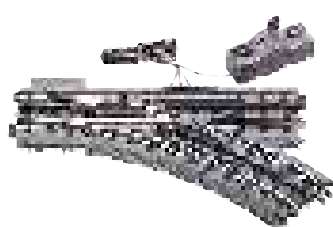

O-31 Switch (RH)
40-1004 \$49.95

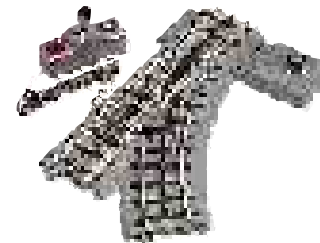

O-42 Switch (LH)
40-1044 \$59.95

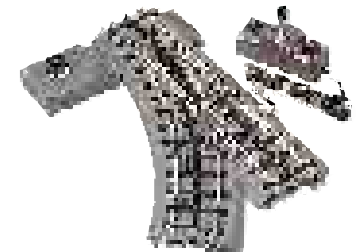

O-42 Switch (RH)
40-1043 \$59.95

Operating Switches

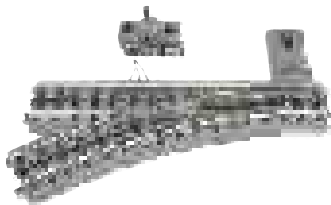

O-54 Switch (LH)
40-1056 \$59.95

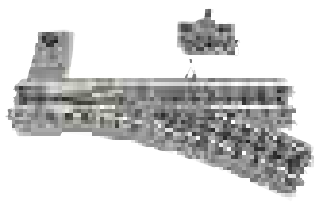

O-54 Switch (RH)
40-1055 \$59.95



RealTrax - O-72 Wye Switch
40-1068 \$79.95

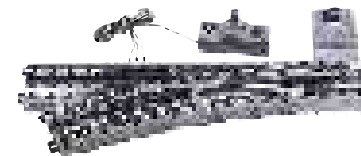

O-72 Switch (LH)
40-1021 \$69.95

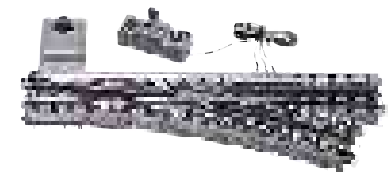

O-72 Switch (RH)
40-1020 \$69.95



O-42/O-31 Curve Switch (LH)
40-1065 \$79.95



O-42/O-31 Curve Switch (RH)
40-1064 \$79.95

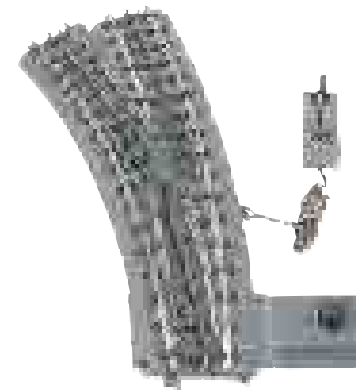

O-72/O-54 Curve Switch (LH)
40-1067 \$99.95



O-72/O-54 Curve Switch (RH)
40-1066 \$99.95

Crossover, Operating & Adapter Track Sections

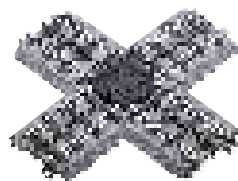

90 Degree Crossover Track
40-1006 \$19.95

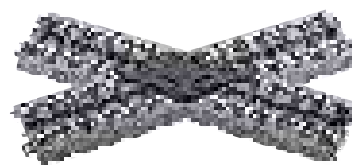

45 Degree Crossover Track
40-1007 \$19.95

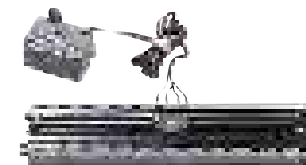

45 Operating Track Section
40-1008 \$29.95



Adapter Track Section
40-1011 \$7.99

Overhead Catenary Systems

Add An Exciting Overhead Catenary System!

The RealTrax Catenary System and RealTrax Catenary Expander are O Gauge's only ready-to-use catenary systems that setup in minutes! Simply position the authentic-looking catenary poles and wires per your layout's requirements, and enjoy the realism of a fully functional easy-to-use catenary system.

Features:

- Compatible with RealTrax or any other O-Gauge Track
- Removable RealTrax Lock-On Base Connection
- Thumbscrew Power Terminals
- Adjustable Pole Spacing
- Adjustable Messenger Beam Height
- Adjustable Wire Positioning
- Base Mounting Screws Included

Catenary Hardware Pack
40-1039 \$19.95

Includes: 4 adjustable messenger expander plates and 4 messenger extension plates to help you custom-fit RailKing Catenary to your layout.



RealTrax - 4-Piece Add on Catenary System
40-1036 \$79.95

8-Piece Catenary System
40-1035 \$149.95

Trestle Systems



8-Piece Elevated Trestle
ABS Construction
40-1034 \$19.95

24-Piece Graduated Trestle
ABS Construction
40-1033 \$29.95

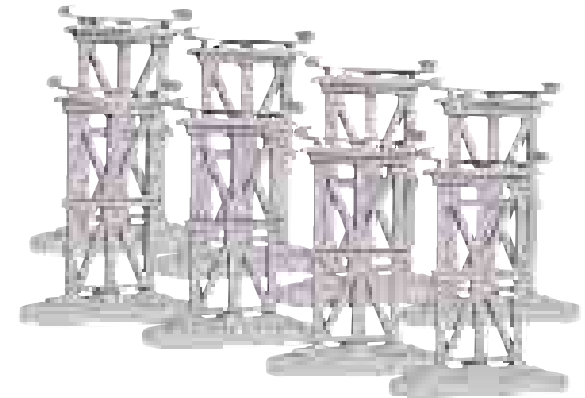

8-Piece Elevated Subway Trestle Set
40-1047 \$19.95

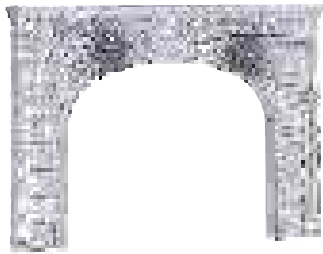

Tunnel Portal (Double)
ABS Construction
40-9015 \$19.95

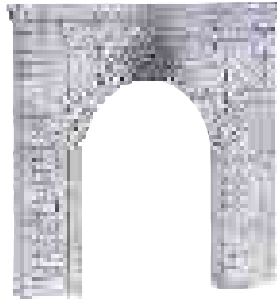

Tunnel Portal (Single)
ABS Construction
40-9014 \$14.95



Wire Harness
Includes: 2 Wires with Male Banana
Plugs at Each End
40-1015 \$3.99

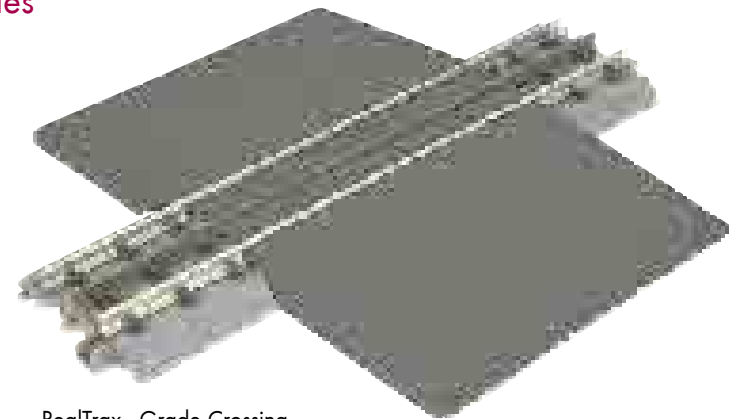

RealTrax - Grade Crossing
40-1009 Measures: 7.5" x 9.5" \$9.95

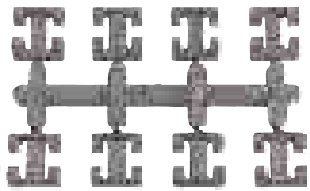

Track Clips (24)
40-1041 \$7.95



Lighted Lock-on
40-1003 \$4.99



Track Activation Device
(I.T.A.D.) 10 Amp Capacity
Beam of infrared Detects a Passing Train
and Turns Accessories On and Off Automatically.
40-1028 \$19.95

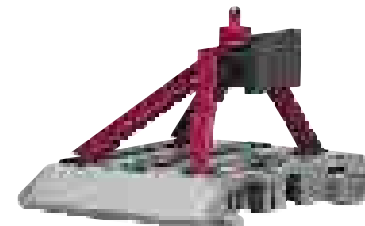

Lighted Bumper
40-1024 \$12.95



Non-Slip Track Pads (50pcs)
40-1046 \$4.95



Includes 2 Stone Bridge Supports
10" in Length

- Bridge Girder (Silver)
Item No. 40-1014 \$19.95
- Bridge Girder (Black)
Item No. 40-1051 \$19.95
- Bridge Girder (Rust)
Item No. 40-1032 \$19.95
- Steel Arch Bridge (Silver)
Item No. 40-1013 \$59.95
- Steel Arch Bridge (Black)
Item No. 40-1050 \$59.95
- Steel Arch Bridge (Rust)
Item No. 40-1031 \$59.95



- 2-Track Steel Arch Bridge (Rust)
Item No. 40-1058 \$89.95
- 2-Track Steel Arch Bridge (Black)
Item No. 40-1060 \$89.95
- 2-Track Steel Arch Bridge (Silver)
Item No. 40-1062 \$89.95
- 2-Track Bridge Girder (Rust)
Item No. 40-1059 \$29.95
- 2-Track Bridge Girder (Black)
Item No. 40-1061 \$29.95
- 2-Track Bridge Girder (Silver)
Item No. 40-1063 \$29.95

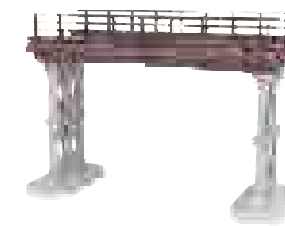

○ Subway Trestle Bridge
40-1048 \$19.95

Layout Builders



Right Hand Track Siding Layout Builder

Includes: (1) RH 0-31 Switch, (4) 10" Straights, (1) 0-31 Curve, (1) Lighted Bumper

Item No. 40-1027 \$79.95



Left Hand Track Siding Layout Builder

Includes: (1) LH 0-31 Switch, (4) 10" Straights, (1) 0-31 Curve, (1) Lighted Bumper

Item No. 40-1026 \$79.95

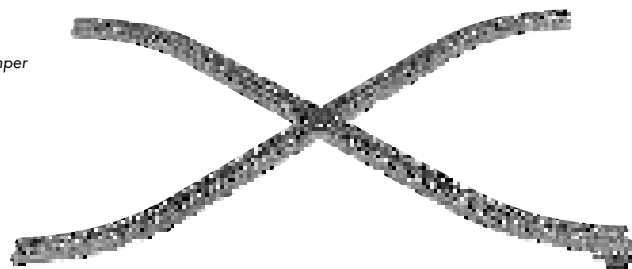
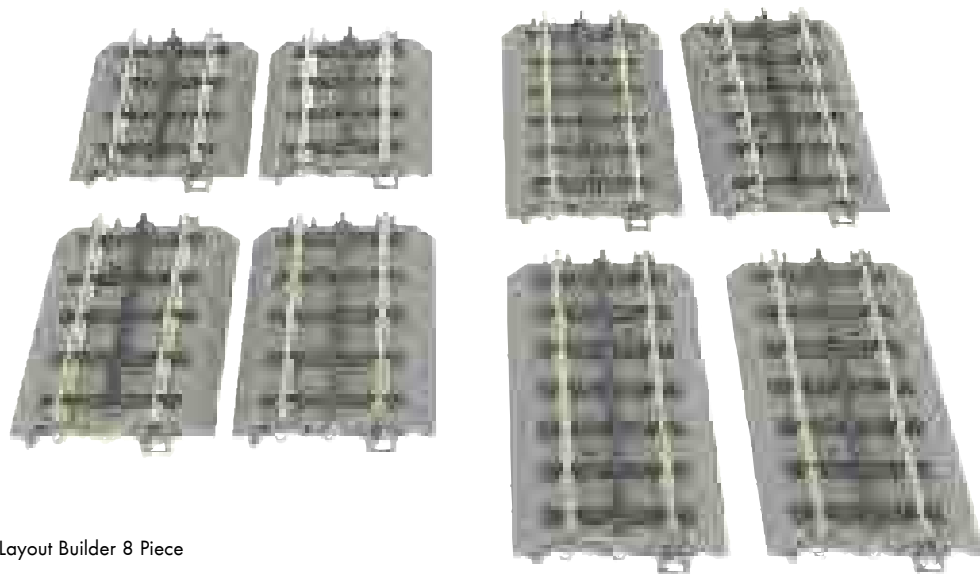
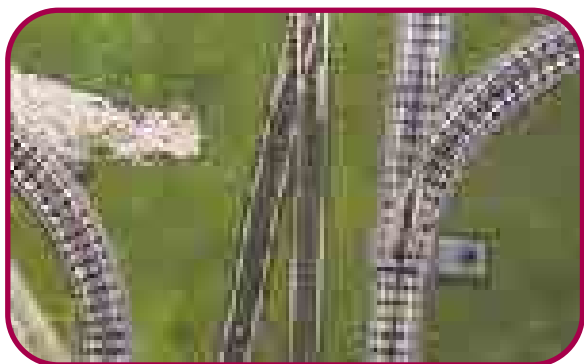

Figure 8 Layout Builder

Includes: (4) 0-31 Curves, (4) 10" Straights, (1) Lighted Lock-On, (1) 90 Degree Crossover

Item No. 40-1025 \$49.95



Layout Builder 8 Piece

Includes: (2) 3.5" Half Tracks, (2) 4.25" Half Tracks, (2) 5" Half Tracks, (2) 5.5" Half Tracks

Item No. 40-1023 \$24.95



EXPAND YOUR TRACK SET LAYOUT

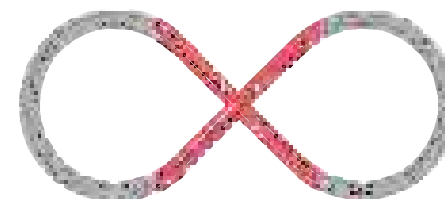

RealTrax Layout Builder
Railing Ready-to-Run Track Components



Bringing Hi-Railing Down to Earth

ScaleTrax by M.T.H. Electric Trains is the ultimate track layout solution for Hi-Railers and other detail-oriented 3-rail modelers who like to keep a permanent layout. No longer will an O Gauge model railroader have to accept the tubular track look, because ScaleTrax is the only 3-rail track system that utilizes realistic looking rails with a more scale sized profile.

Whether assembling your first layout or replacing your old track for a scale look, ScaleTrax is the most realistic and durable 3-rail O Gauge track system available today.

Straight, Flex and Operating Track Sections



1.75" Straight Track Section
45-1011 \$2.49



4.25" Straight Track Section
45-1012 \$3.50



5" Straight Track Section
45-1013 \$3.50



10" Straight Track Section
45-1001 \$3.25



5.5" Straight Track Section
45-1014 \$3.50

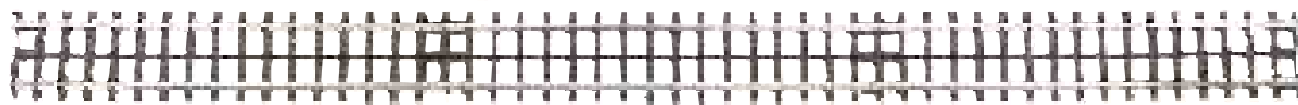

30" Straight Track Section
45-1019 \$9.95

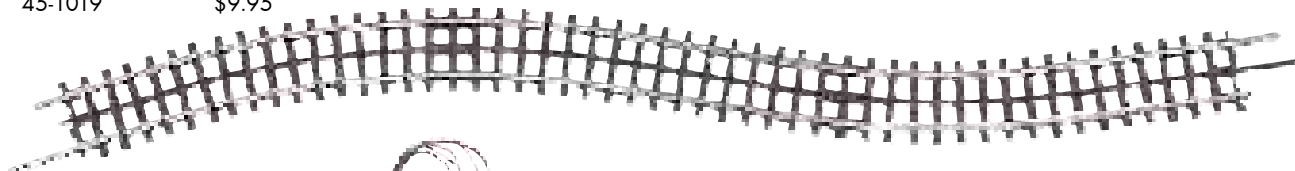

30" FlexTrack Section
Requires 1 Lock-on Per FlexTrack Section.
45-1049 \$9.95

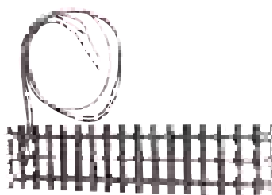

Lock-on (Track Not Included)
Each FlexTrack Section Requires (1) Lock-on
45-1033 \$3.99



15" Operating Track Section
45-1035 \$19.95



It takes **EIGHT 0-31 CURVES** to make a circle.
It takes **TWELVE 42 CURVES** to make a circle.
It takes **TWELVE 54 CURVES** to make a circle.
It takes **SIXTEEN 0-72 CURVES** to make a circle.
It takes **SIXTEEN 0-82 CURVES** to make a circle.

Lowest Profile, Most Realistic 3-Rail Track in O Gauge!



Curved Track Sections

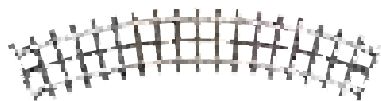

O-31 Curved Track Section
45-1002 \$3.50



O-54 Curved Track Section
45-1007 \$3.50

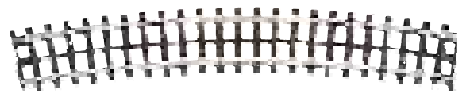

O-72 Curved Track Section
45-1010 \$4.75



O-80 Curved Track Section
45-1034 \$4.99

Accessories



Bumper
45-1025 \$15.95



O Scale ITAD Signal Box
45-1028 \$29.95

Crossovers

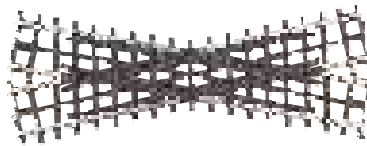

22.5 Degree Crossing
45-1015 \$19.95

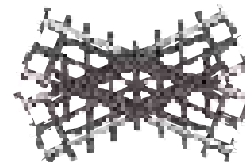

45 Degree Crossing
45-1006 \$19.95

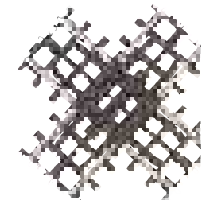

90 Degree Crossing
45-1005 \$19.95

Directional Switches: Left and Right



No. 4 Switch (LH)
45-1050 \$59.95
No. 4 Switch (RH)
45-1051 \$59.95



No. 6 Switch (LH)
45-1052 \$69.95
No. 6 Switch (RH)
45-1053 \$69.95



O-54 Switch (LH)
45-1008 \$49.95
O-54 Switch (RH)
45-1009 \$49.95



O-31 Switch (LH)
45-1003 \$49.95
O-31 Switch (RH)
45-1004 \$49.95

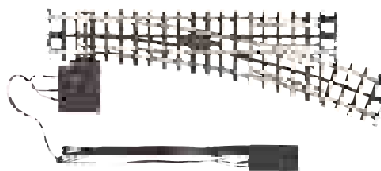

ScaleTrax - O-72 Switch (L)
45-1021 \$49.95

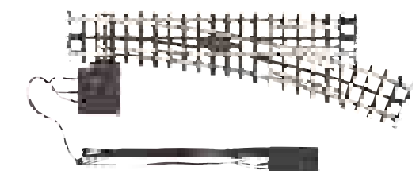

RealTrax - O-72 Switch (RH)
45-1020 \$49.95

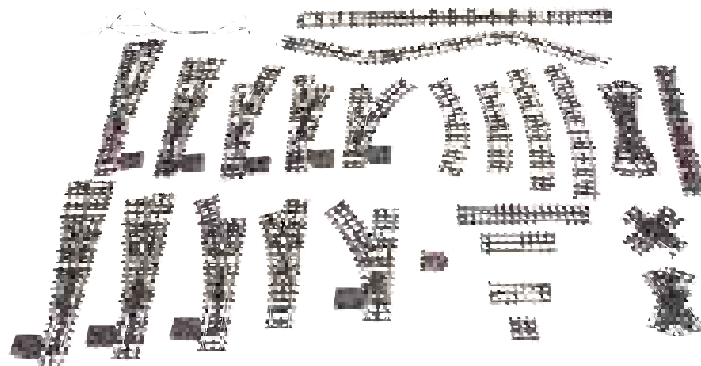

Warning signs like our operating crossing gate (complete with ringing warning bell, flashing lights and crossing arm that lowers) and traffic lights keep the townspeople safe. Streetlights and hi-tension towers turn your layout into a real-looking, recognizable town.

M.T.H. offers a variety of RailTown™ buildings to help you create whatever kind of atmosphere you desire: rural or urban, nostalgic or modern. Operating buildings transfer your layout's action from trains to structures adding fun and excitement to the entire pike. RailTown buildings are a perfect addition on any O Gauge layout, as each is sized for use with all O Gauge locomotives and rolling stock.

Many RailKing operating accessories bring a layout to life via real-world movement and operation. In addition to lights and signals there are many operating buildings. An SUV pulling through a McDonald's® drive-thru after ordering, a coaling tower that lifts buckets of coal and dumps them into a waiting hopper car, a fill-up at the local gas station, log operations at the saw mill and much more are awaiting owners of RailKing operating buildings. Each fully assembled and ready to use means your layout transformation into a world of action is just a few minutes away.

As you peruse the next few pages, you'll find that we've divided the accessory section into four categories: RailTown buildings, traditional accessories that feature the classic "Tinplate" look for the mid-20th century, miscellaneous accessories like bags of coal or smoke fluid, and O Scale accessories complete with scale proportioned, well-detailed models that make a layout incredibly realistic.

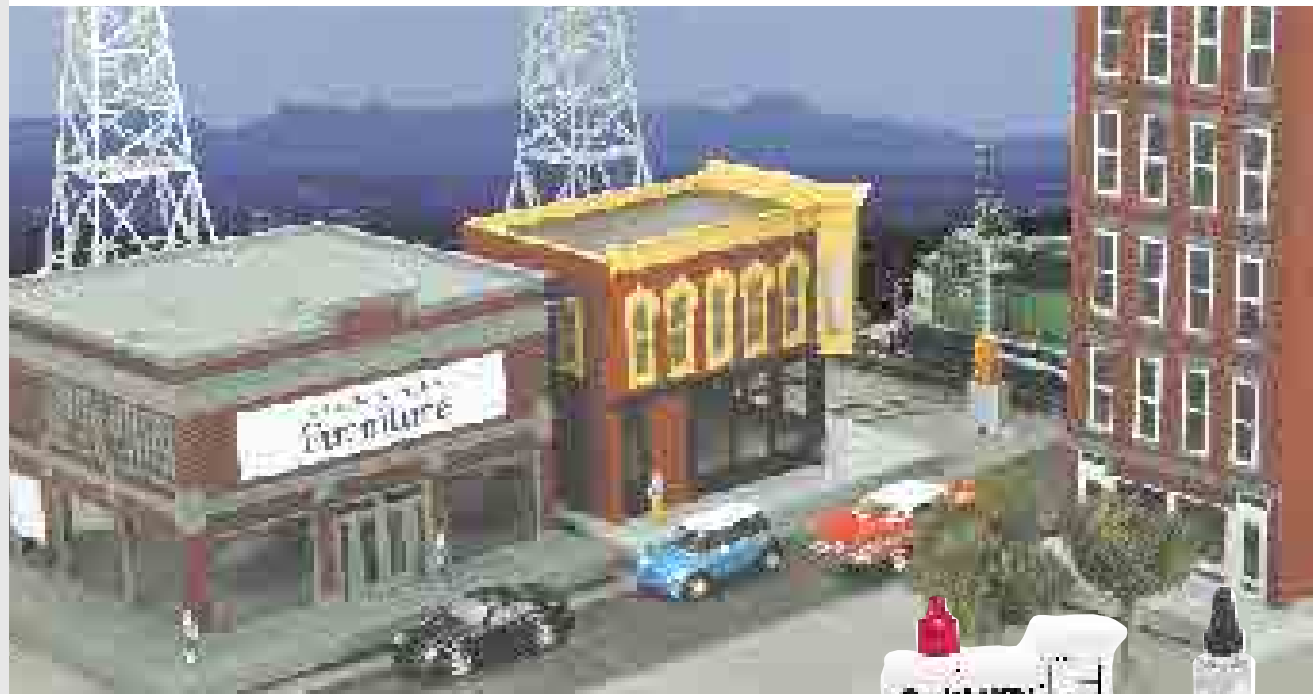

■ American Flag Pole/Flag
30-9074 \$19.95
Unit Measures: 4 3/8 x 10 3/8"



■ Bag Of Coal
30-50005 \$3.99



■ Maintenance Kit
30-50010 \$14.95



■ O Ga. Track Activation Device (TAD)
10-1037 \$9.95

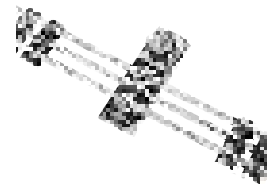

■ O/Std. Gauge Lighted Lockon
10-1021 \$3.99



■ ProtoSmoke™ Fluid 7 OZ Size

Unscented	60-1045	\$9.95
Christmas	60-1046	\$12.95
Coal	60-1047	\$12.95
Diesel	60-1048	\$12.95
Woodburning	60-1049	\$12.95

■ ProtoSmoke™ Fluid 2.0 OZ Size

Christmas	60-1051A	\$4.99
Coal	60-1051B	\$4.99
Diesel	60-1051C	\$4.99
Wood Burning	60-1051D	\$4.99
Coffee	60-1051E	\$4.99
Eggs & Bacon	60-1051F	\$4.99
Vanilla	60-1051G	\$4.99
Candy Cane	60-1051H	\$4.99
Barbeque	60-1051I	\$4.99
Pipe Smoke	60-1051J	\$4.99
Cinnamon Roll	60-1051K	\$4.99
Apple Pie	60-1051L	\$4.99

■ ProtoSmoke™ Fluid 36-Pack Assortment
2 OZ. Size 60-1051 \$179.95

- Miscellaneous Accessories
- O Scale Accessories
- Traditional Accessories
- Signature Series Accessories



6-Piece Figure Set #3 - Diner Patrons
30-11047 \$19.95



6-Piece Figure Set #5 - Cops & Robbers
30-11056 \$19.95



6-Piece Figure Set #4 - Bus Station Employees & Patrons
30-11048 \$19.95



6-Piece Figure Set #2 - Fire House Employees
30-11046 \$19.95



6-Piece Figure Set #8 - Fire Scene
30-11060 \$19.95



8-Piece Locomotive Cab Figure Set
30-11064 \$29.95



6-Piece Figure Set - Outdoor People
30-11057 \$19.95

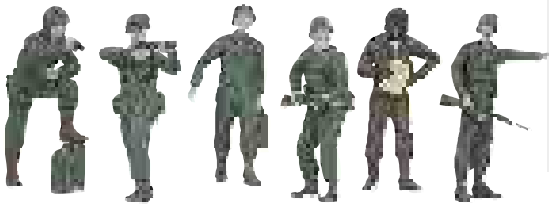

6-Piece Figure Set #7 - Army
30-11059 \$19.95



12-Piece Passenger Figure Set - Passenger #1
30-11016 \$29.95



10-Piece Figure Set - Army/Navy
30-11065 \$29.95

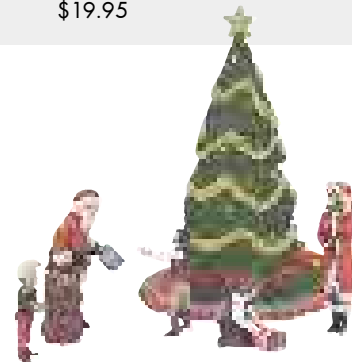

6-Piece Figure Set - Christmas
30-11062 \$24.95



12-Piece Passenger Figure Set - Passenger #3
30-11067 \$29.95



12-Piece Passenger Figure Set - Subway
30-11063 \$29.95

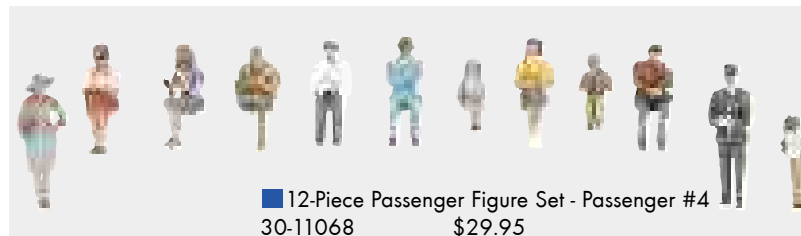

12-Piece Passenger Figure Set - Passenger #4
30-11068 \$29.95



120-Piece Passenger Figure Set - Undecorated
30-11043 \$29.95

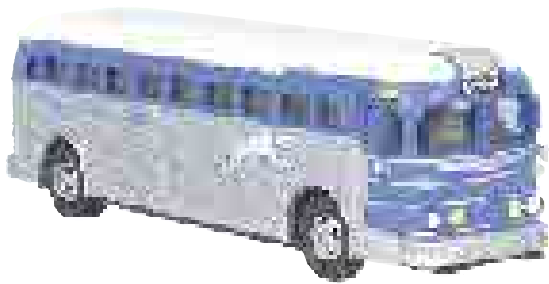

■ Die-Cast Bus - Greyhound®
 30-50017 \$29.95
 Unit Measures: 8 x 1 15/16 x 2 1/8

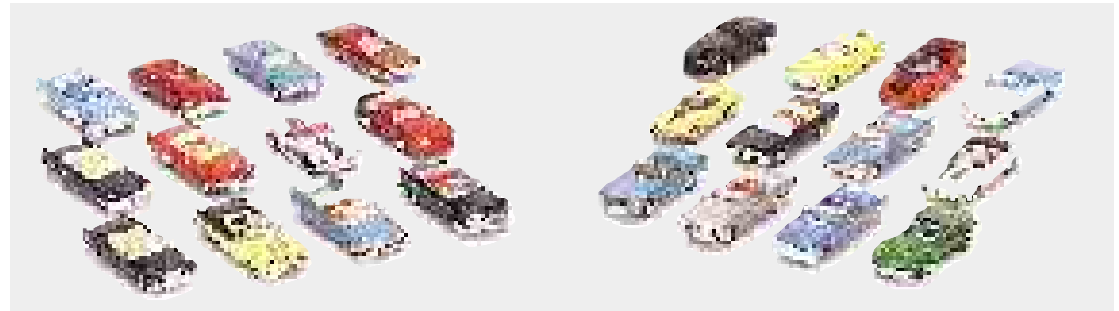

■ 24 Pack Roadster Vehicle Set - Roadster Convertibles
 30-50025 \$119.95

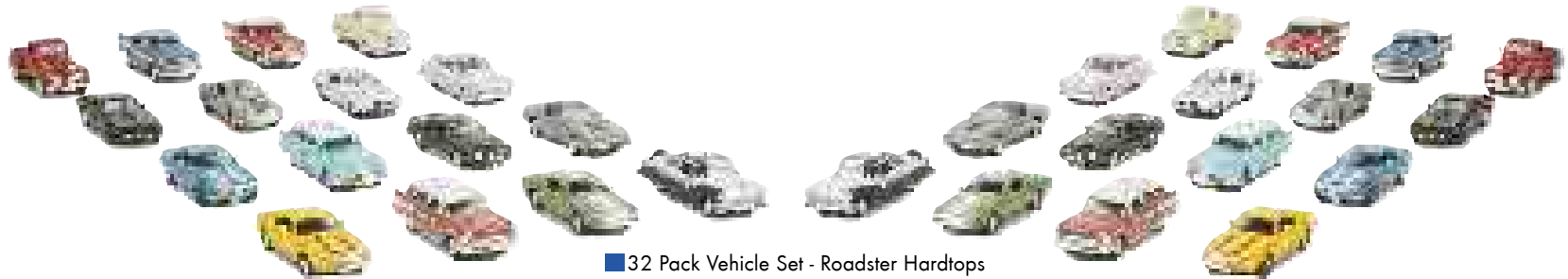

■ 32 Pack Vehicle Set - Roadster Hardtops
 30-50031 \$159.95



■ Subway Entrance - Yankee Stadium
 30-90073 \$29.95
 Unit Measures: 3 5/8" x 1 3/4" x 2"



■ Subway Entrance - Canal Street
 30-90102 \$29.95
 Unit Measures: 3 5/8" x 1 3/4" x 2"



■ Subway Entrance - Times Square
 30-90101 \$29.95
 Unit Measures: 3 5/8" x 1 3/4" x 2"

■ Miscellaneous Accessories

■ O Scale Accessories

■ Traditional Accessories

■ Signature Series Accessories

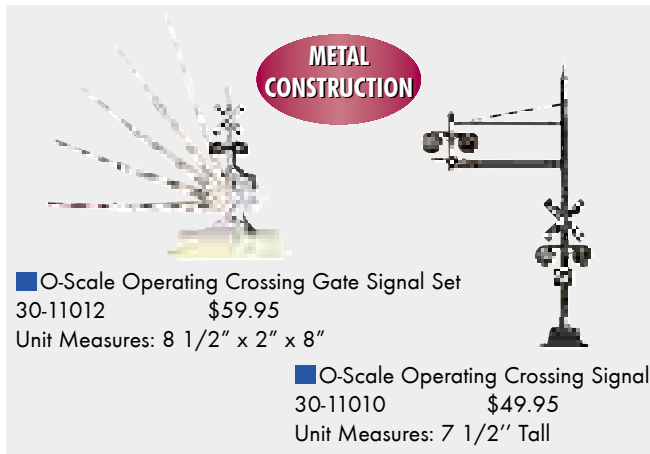

METAL CONSTRUCTION

■ O-Scale Operating Crossing Gate Signal Set
30-11012 \$59.95
Unit Measures: 8 1/2" x 2" x 8"

■ O-Scale Operating Crossing Signal
30-11010 \$49.95
Unit Measures: 7 1/2" Tall

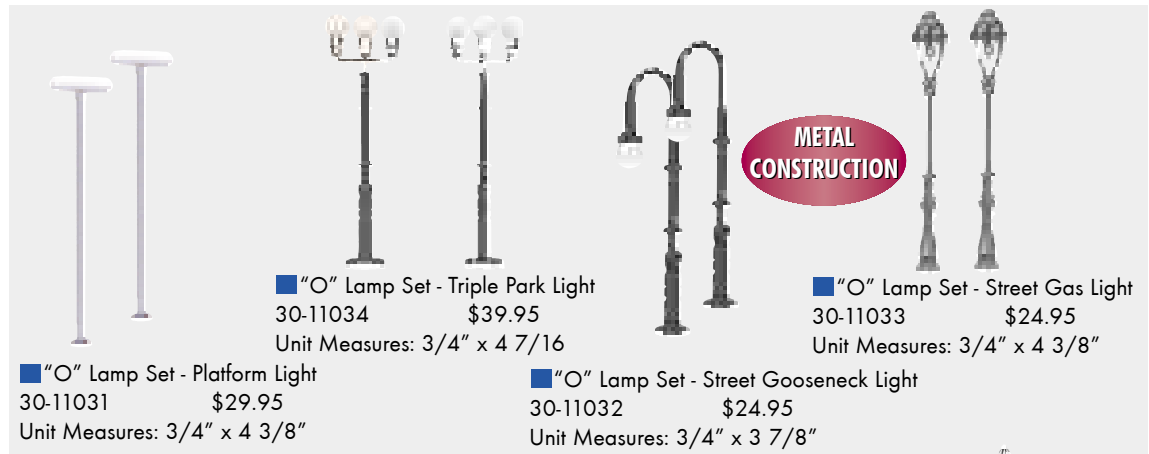

METAL CONSTRUCTION

■ "O" Lamp Set - Triple Park Light
30-11034 \$39.95
Unit Measures: 3/4" x 4 7/16"

■ "O" Lamp Set - Platform Light
30-11031 \$29.95
Unit Measures: 3/4" x 4 3/8"

■ "O" Lamp Set - Street Gooseneck Light
30-11032 \$24.95
Unit Measures: 3/4" x 3 7/8"

■ "O" Lamp Set - Street Gas Light
30-11033 \$24.95
Unit Measures: 3/4" x 4 3/8"

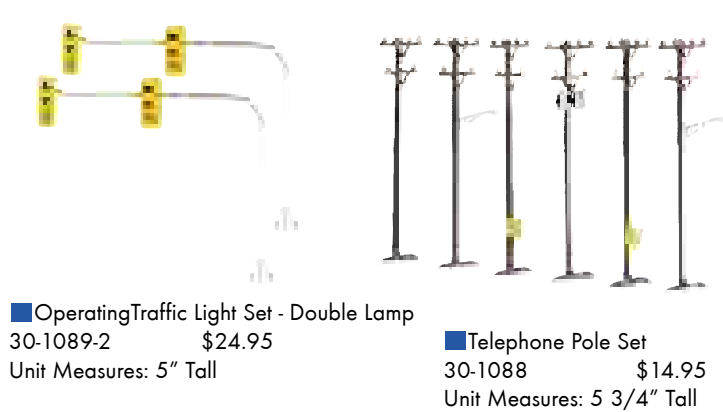

■ Operating Traffic Light Set - Double Lamp
30-1089-2 \$24.95
Unit Measures: 5" Tall

■ Telephone Pole Set
30-1088 \$14.95
Unit Measures: 5 3/4" Tall

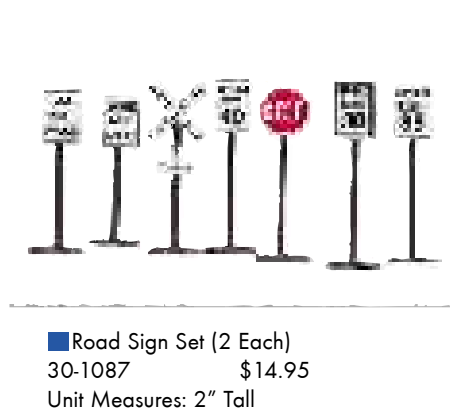

■ Road Sign Set (2 Each)
30-1087 \$14.95
Unit Measures: 2" Tall



■ Operating Traffic Light Set - Single Lamp
30-1089-1 \$19.95
Unit Measures: 5" Tall



HOUSE NOT INCLUDED

■ Fence Set
30-50002 \$9.95
Unit Measures: 16" x 13"



■ O Scale 4 Piece Flashing Barricades Set
30-11021 \$19.95
Unit Measures: 1" x 1" x 2"



METAL CONSTRUCTION

■ O Scale Water Column
30-11007 \$29.95
Unit Measures: 4" Tall

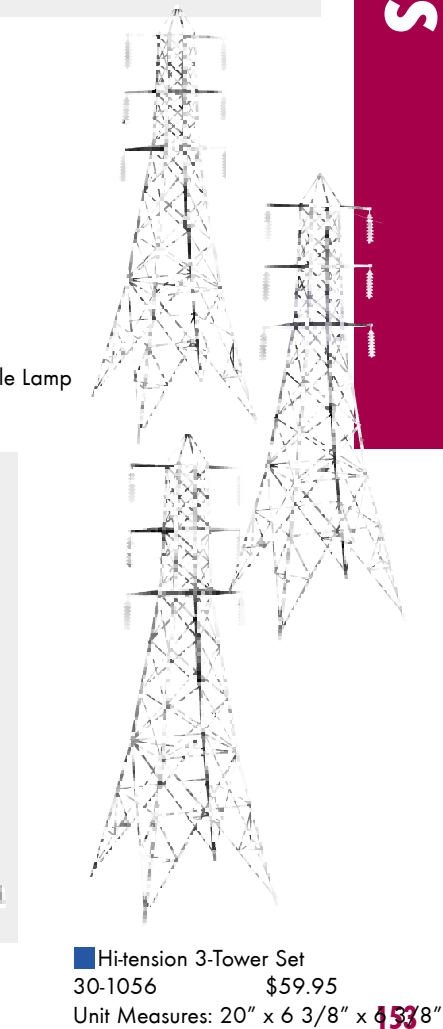

■ Hi-tension 3-Tower Set
30-1056 \$59.95
Unit Measures: 20" x 6 3/8" x 4 3/8"



■ "O" Scale Operating Crossing Flasher Set w/Sound
30-11014 \$49.95
Unit Measures: 5 1/2" x 2 1/2" x 1"

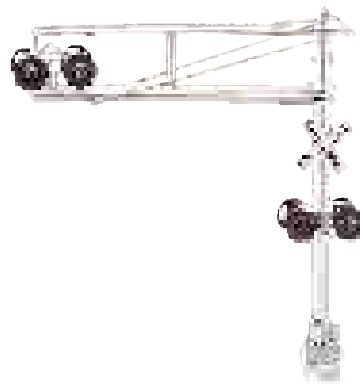

■ "O" Scale Modern Operating Crossing Signal
30-11006 \$49.95
Unit Measures: 7" Tall



■ "O" Scale Operating Block Signal
30-11005 \$29.95
Unit Measures: 8" Tall



■ "O" Scale Vertical Signal lamps
30-11009A \$9.95
Unit Measures: 1 1/4" Tall

■ "O" Scale Cantilevered Signal Bridge
30-11009 \$49.95
Unit Measures: 8 1/2" x 2 1/2" x 6 1/2"

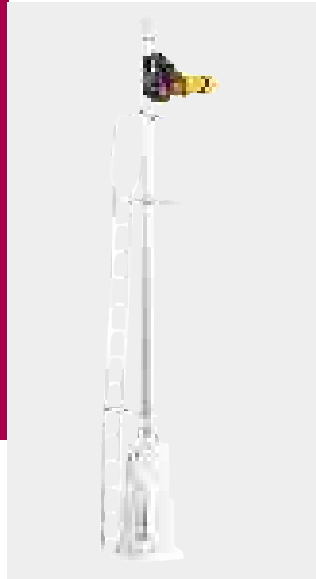

■ "O" Scale 3-Position Semaphore
30-11023 \$39.95
Unit Measures: 7" Tall



■ "O" Scale 1 Over 1 Signal
30-11025 \$49.95
Unit Measures: 7" Tall

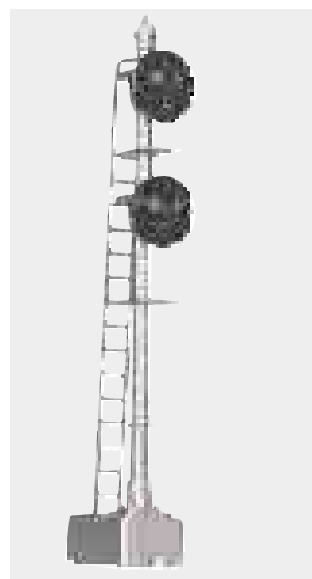

■ "O" Scale 2-Head Target Signal
30-11035 \$49.95
Unit Measures: 7 3/8" Tall



■ "O" Scale 7 Light Block Signal
30-11013 \$39.95
Unit Measures: 7" x 1 1/2" x 2"



■ "O" Scale 3 Over 3 Vertical Signal
30-11024 \$49.95
Unit Measures: 6 3/4" Tall

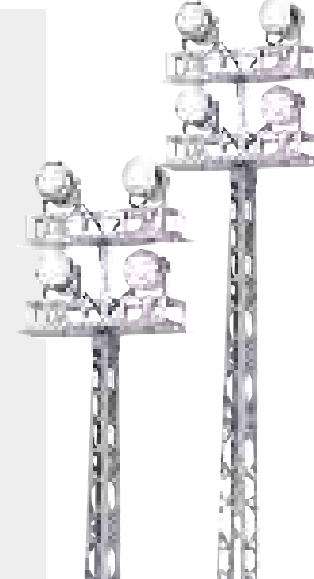

■ "O" Scale Floodlight 2-Tower Set
30-11039 \$59.95
Unit Measures: 3" x 1 1/8" x 13 1/2"



■ "O" Scale Dwarf Signal
30-11011 \$24.95
Unit Measures: 1" x 1 7/8" x 1 3/4"

■ "O" Scale Modern Dwarf Signal
30-11038 \$24.95
Unit Measures: 1 1/2" x 1" x 2 1/8"

- Miscellaneous Accessories
- "O" Scale Accessories
- Traditional Accessories
- Signature Series Accessories



■ Lighted Billboard - DCS
30-90041 \$29.95
Unit Measures: 7 1/2" x 5 3/4" x 6"



■ I-Beam 8-Piece Set - MTH Steel
30-50007 \$12.95
Unit Measures: 7 1/4" Long



■ 8-Piece Log Set
30-50008 \$14.95
Unit Measures: 5" Long

■ Lighted Billboard - Freedom Land
30-90045 \$29.95
Unit Measures: 7 1/2" x 5 3/4" x 6"

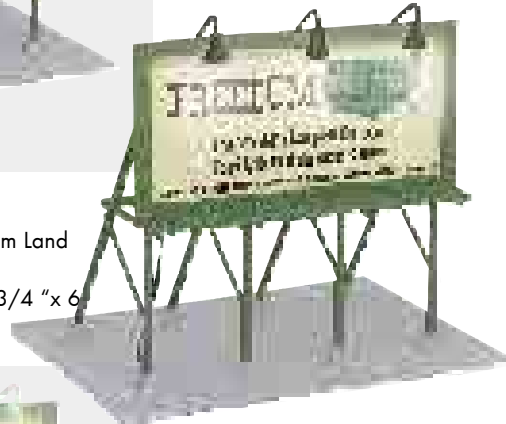

■ 6-Piece Barrel Set
30-50024 \$9.95

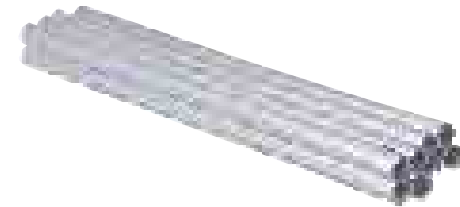

■ 8-Piece Pipe Set
30-50023 \$9.95



■ Lighted Billboard - Creamsicle
30-90089 \$29.95
Unit Measures: 7 1/2" x 5 3/4" x 6"



■ 2-Piece Crate Set
30-50027 \$9.95

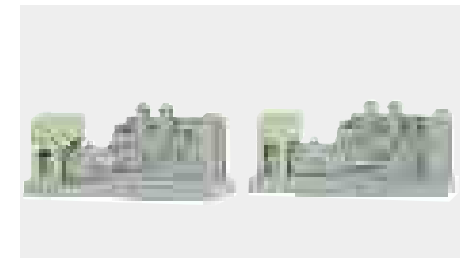

■ 2-Piece Generator Set
30-50028 \$9.95

Popsicle, Klondike, Good Humor are registered trademarks of Good Humor-Breyers

■ Lighted Billboard - Popsicle
30-90090 \$29.95
Unit Measures: 7 1/2" x 5 3/4" x 6"

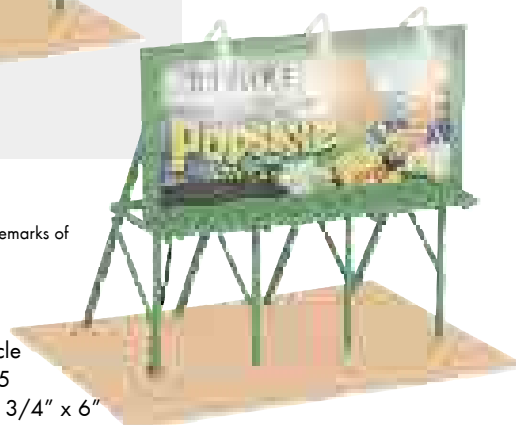

■ 2-Piece LCL Container Set
30-50030 \$14.95



■ 2-Piece Cement LCL Container Set
30-50029 \$14.95



Operating O Scale Water Tower
30-11028 \$69.95
Unit Measures: 7 1/2" x 11" x 10 1/4"



Switch Tower - Pennsylvania ZOO
30-90098 \$39.95
Unit Measures: 6 1/8" x 10 1/2" x 9"



Switch Tower - Western Maryland
30-90114 \$39.95
Unit Measures: 6 1/8" x 10 1/2" x 9"

Switch Tower - Denver Rio Grande
30-90113 \$39.95
Unit Measures: 6 1/8" x 10 1/2" x 9"



Trackside Yard Tower - Gray & Maroon
30-90006 \$29.95
Unit Measures: 4" x 4" x 7 1/2"

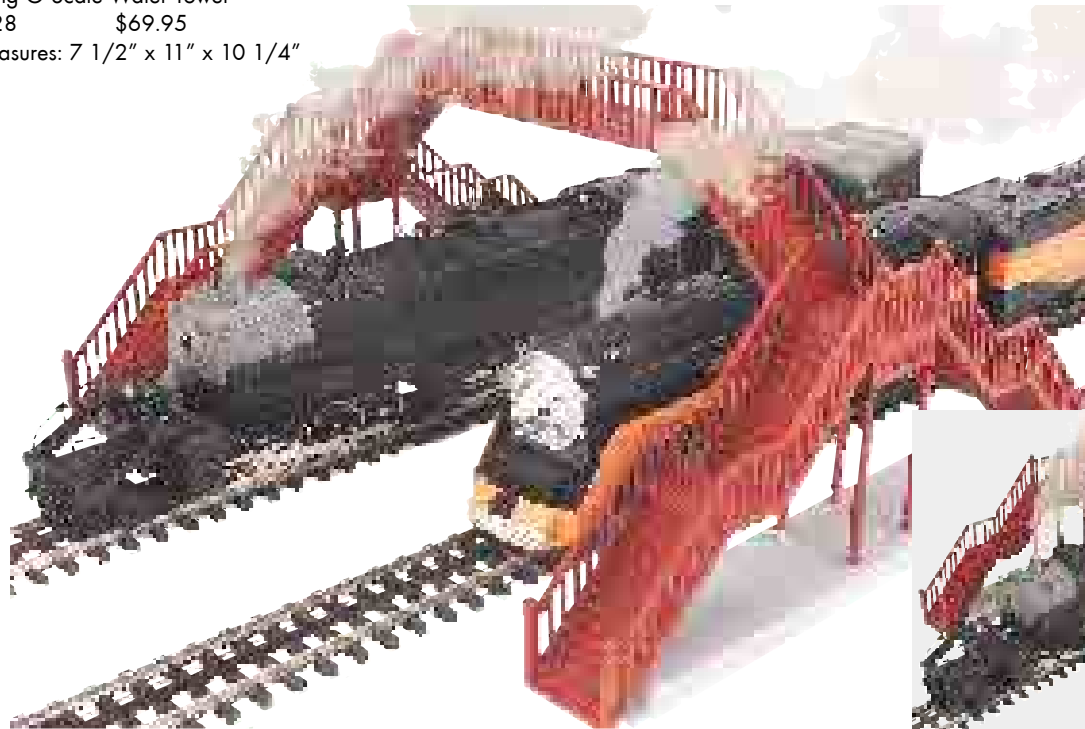

O Scale Pedestrian 2-Track Crosswalk
30-9066 \$59.95
Unit Measures: 16 1/8" x 13 3/8" x 7 7/8"



O Scale Yard Master Tower
30-11027 \$54.95
Unit Measures: 8 1/4" x 7 7/8" x 11"

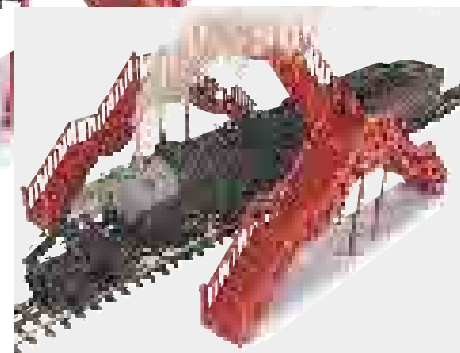

O Scale Pedestrian Crosswalk
30-9053 \$49.95
Unit Measures: 11 5/8" x 13 3/8" x 7 7/8"



Elevated Gate Tower - Brown & Black
30-9097 \$24.95
Unit Measures: 3 1/2" x 2 1/2" x 5 3/4"



Operating Station Platform - Military
 30-9145 \$49.95
 Unit Measures: 10" x 3 1/2" x 4"



Operating Station Platform
 30-9152 \$49.95
 Unit Measures: 10" x 3 1/2" x 4"



Bus Station Dock
 30-9071 \$29.95
 Unit Measures: 14 5/8" x 5 1/8" x 3 7/8"

Passenger Station Platform - Brown w/gray roof
 30-9006 \$19.95
 Unit Measures: 10" x 3 1/2" x 4"

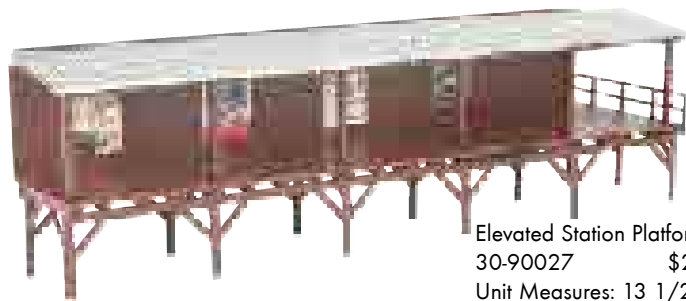
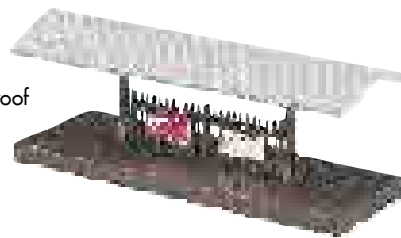

Elevated Station Platform
 30-90027 \$29.95
 Unit Measures: 13 1/2" x 5 1/2" x 4"

Operating Freight Platform
 30-9151 \$49.95
 Unit Measures: 10" x 3 1/2" x 4"



Passenger Station w/dual Platforms - Red w/gray roof
 30-9014 \$79.95
 Unit Measures: 37" x 13 1/2" x 8 1/2"

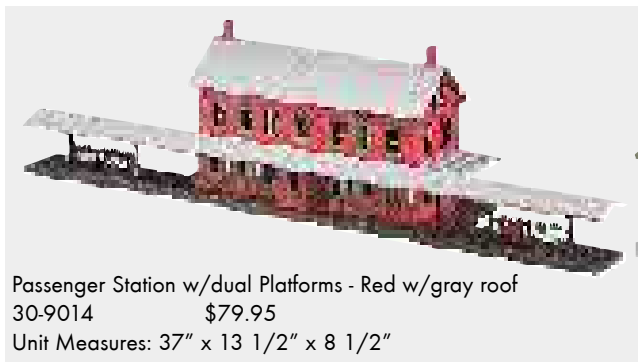

Passenger Station w/dual Platforms - Dark Red Stone
 30-90094 \$79.95
 Unit Measures: 37" x 13 1/2" x 8 1/2"



#4 Country House
30-90053 \$34.95
Unit Measures: 9 5/8" x 5" x 7"

#4 Country House - Yellow
30-9081 \$34.95
Unit Measures: 9 5/8" x 5" x 7"



3-Story Town House #3 - Dark Brown & Cream
30-9080 \$34.95
Unit Measures: 6 3/8" x 3 15/16" x 7 1/8"

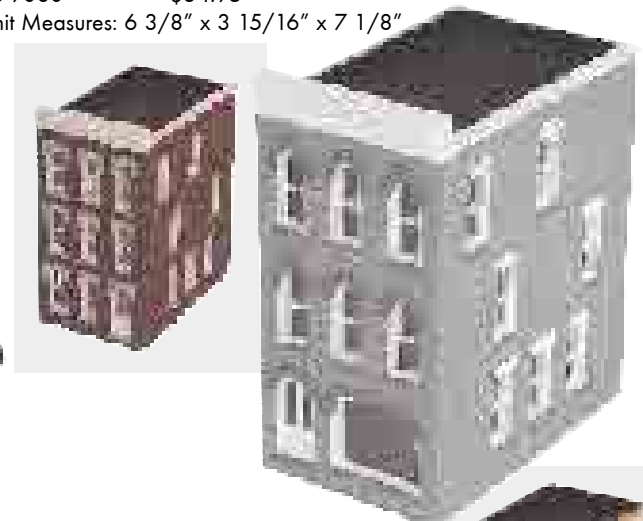

3-Story Town House #1 - Gray & White
30-9078 \$34.95
Unit Measures: 6 3/8" x 3 15/16" x 7 1/8"

3-Story Town House #2 - Cream & Gray
30-9079 \$34.95
Unit Measures: 6 3/8" x 3 15/16" x 7 1/8"

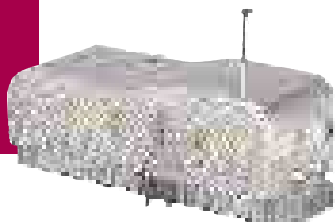

Stainless Mobil Home
30-90005 \$29.95
Unit Measures: 7 1/8" x 2 3/8" x 2 3/4"

Stainless Mobil Home - Salmon & White
30-90109 \$29.95
Unit Measures: 7 1/8" x 2 3/8" x 2 3/4"

Stainless Mobil Home - Turquoise & White
30-90108 \$29.95
Unit Measures: 7 1/8" x 2 3/8" x 2 3/4"

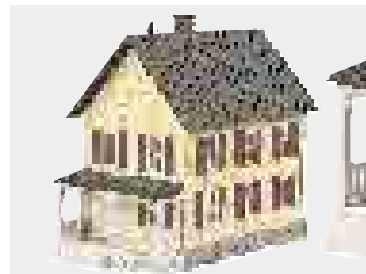
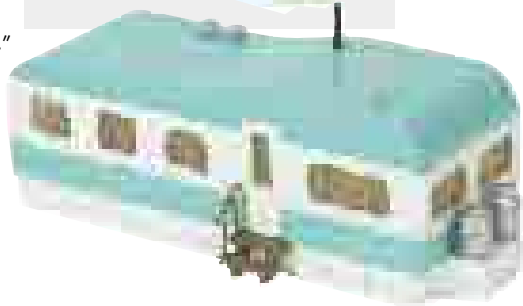
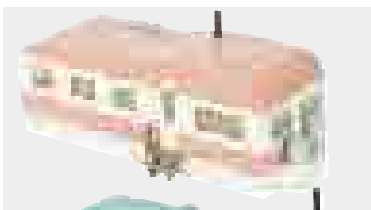

Row House #2 - Tan/Brown
30-90120 \$29.95
Unit Measures: 8 1/2" x 4 5/8" x 7"



Row House #2 - Off White / Green
30-90119 \$29.95
Unit Measures: 8 1/2" x 4 5/8" x 7"



#6 Farm House - Gray
30-90054 \$34.95
Unit Measures: 7 1/2" x 7 1/2" x 7"



#6 Farm House- Cream / Dark Green
30-90115 \$34.95
Unit Measures: 7 1/2" x 7 1/2" x 7"

Work House #1 - Mustard & Red
30-90008 \$29.95
Unit Measures: 8 5/8" x 4 7/16" x 4 7/8"



Work House #1 - Blue & Black
30-90009 \$29.95
Unit Measures: 8 5/8" x 4 7/16" x 4 7/8"



#6 Farm House - Tan / Maroon
30-90116 \$34.95
Unit Measures: 7 1/2" x 7 1/2" x 7"



Work House #2 - Cream & Oxide
30-90011 \$29.95
Unit Measures: 8 5/8" x 4 7/16" x 4 7/8"



Out House - Gray & White
30-90001 \$12.95
Unit Measures: 1 3/16" x 1 5/16" x 2 7/16"

Row House #1 - Yellow / Green
30-90118 \$29.95
Unit Measures: 7 7/8" x 4 5/8" x 7"



Work House #2 - Gray & Black
30-90010 \$29.95
Unit Measures: 8 5/8" x 4 7/16" x 4 7/8"



#5 Country Church - White & Red
30-90057 \$29.95
Unit Measures: 7 7/8" x 4 5/8" x 10 9/16"



Row House #1 - Gray / Red
30-90117 \$29.95
Unit Measures: 7 7/8" x 4 5/8" x 7"



Schoolhouse - Yellow w/Dk. Gray Roof
30-90031 \$34.95
Unit Measures: 9 1/4" x 6 1/8" x 5"



Barn - Red & White
30-9072 \$69.95
Unit Measures: 16 1/2" x 18 3/4" x 9 1/2"



Brewery - Pittsburgh Brewing Co.
30-90079 \$99.95
Unit Measures: 19 3/8" x 8 5/16" x 6 5/8"



Country Freight Station - Red & Black
30-90004 \$34.95
Unit Measures: 9" x 5 1/2" x 5"



Tool Shed - Railway
30-90100 \$29.95
Unit Measures: 4 1/2" x 5 1/8" x 3 7/16"

OPENING
DOORS



Country Passenger Station - Railtown
30-9087 \$49.95
Unit Measures: 18 5/8" x 7 3/8" x 6 5/8"



Country Passenger Station - Main Street
30-90081 \$49.95
Unit Measures: 18 5/8" x 7 3/8" x 6 5/8"



Dry Goods Transfer Warehouse - Fairview Feed
30-90047 \$59.95
Unit Measures: 13 1/2" x 8 1/4" x 9 1/8"



Freight Transfer Warehouse - Beige & Black
30-9098 \$79.95
Unit Measures: 13 3/16" x 8 3/4" x 6 3/16"



Dry Goods Transfer Warehouse - New York Central
30-90112 \$59.95
Unit Measures: 13 1/2" x 8 1/4" x 9 1/8"

OPENING DOORS
AND
INTERIOR LIGHTING



Grainery - Red Stone
30-90086 \$59.95
Unit Measures: 10 1/4" x 7" x 11 1/8"



Dry Goods Transfer Warehouse - Grace Valley Feed and Supply
30-90082 \$59.95
Unit Measures: 13 1/2" x 8 1/4" x 9 1/8"



Power Station - Cream & Dark Gray
30-90003 \$29.95
Unit Measures: 4 1/4" x 4 1/8" x 3 7/8"



Jail House - County Jail
30-90014 \$29.95
Unit Measures: 4 1/4" x 4 1/8" x 3 7/8"

Operating Watchman's Shanty - Pennsylvania
30-9147 \$59.95
Unit Measures: 4 1/2" x 5 15/16" x 4 1/8"



Operating Watchman's Shanty - Navy Patrol
30-9146 \$59.95
Unit Measures: 4 1/2" x 5 15/16" x 4 1/8"

Operating Watchman's Shanty - Gray & Black
30-9129 \$59.95
Unit Measures: 4 1/2" x 5 15/16" x 4 1/8"

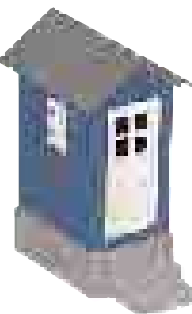
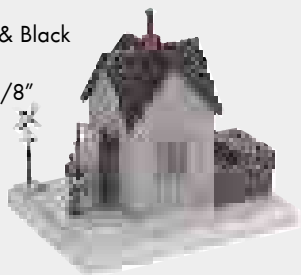

Telephone Shanty - Blue & White
30-90002 \$12.95
Unit Measures: 2" x 1 5/16" x 2 11/16"



Work Office - Brown
30-90012 \$39.95
Unit Measures: 11 1/2" x 3" x 4"

**FLICKERING FIRE
AND
OPERATING LIGHTS**



Yard Office - Orange
30-90013 \$39.95
Unit Measures: 11" x 6 11/16" x 3 3/8"



Engine Shed - Pennsylvania Railroad
30-90083 \$99.95
Unit Measures: 24" x 8 1/2" x 13 1/2"



Logging Camp Bunk House - Elk River Logging Co.
30-90037 \$34.95
Unit Measures: 9 1/4" x 6 1/8" x 5"

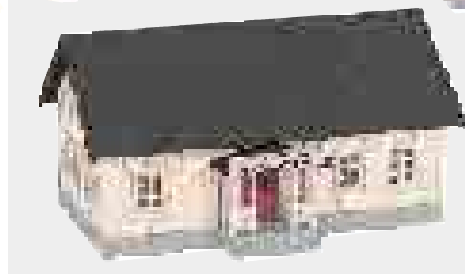

Assembly Hall - West Virginia Pulp & Paper Co.
30-90036 \$34.95
Unit Measures: 9 1/4" x 6 1/8" x 5"

Bank w/Coin Slot - National Bank
 30-9075 \$59.95
 Unit Measures: 9 1/2" x 17 15/16" x 9 1/8"



Police Station - Gray & Black
 30-9099 \$59.95
 Unit Measures: 13 1/4" x 8 3/8" x 10"



Motorcycle Dealership - Harley-Davidson®
 30-90111 \$59.95
 Unit Measures: 9 3/8" x 9 3/8" x 6 3/8"

 Harley-Davidson® Goods, Registered Trademark of H-D Michigan, Inc.
 © H-D®. All Rights Reserved.



Public Works Building - Gray & White
 30-90007 \$79.95
 Unit Measures: 14 1/8" x 9 7/8" x 8 1/8"



Furniture Store - Miller & Sons Furniture
 30-90025 \$49.95
 Unit Measures: 9 3/8" x 9 3/8" x 6 3/8"



Automobile Dealership - Smith Brothers
 30-90021 \$49.95
 Unit Measures: 9 3/8" x 9 3/8" x 6 3/8"

Used Car Lot - Bill's
 30-90040 \$99.95
 Unit Measures: 16 1/8" x 5" x 8 1/8"





House On Fire - Blue & White
30-9139 \$129.95
Unit Measures: 7 1/2" x 7 1/2" x 7"

FIRE TRUCK NOT INCLUDED

House On Fire - Tan & Black
30-9142 \$129.95
Unit Measures:
7 1/2" x 7 1/2" x 7"



Operating Firehouse - Engine Company 1 w/red fire truck
30-9136 \$149.95
Unit Measures: 16 5/8" x 15 3/8" x 12 3/8"



**WITH MUSIC
AND
MOVING CARS**

Operating McDonalds
30-9114 \$179.95
Unit Measures: 17" x 17" x 7 3/4"

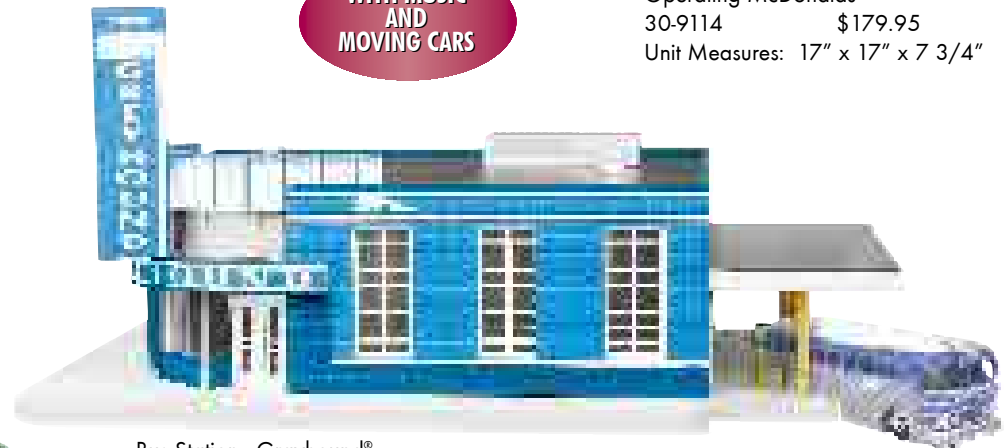

Bus Station - Grayhound®
30-9040 \$129.95
Unit Measures: 16 1/2" x 18 3/4" x 9 1/2"



**WITH MUSIC
AND
MOVING CARS**

Operating Drive-In Diner - Al's
30-9148 \$179.95
Unit Measures: 21 5/8" x 9" 13 1/8"

**MOVING
SKATER
FIGURES**

Fast Food Restaurant Stand - Burger Chef
 30-90084 \$59.95
 Unit Measures: 14 1/2" x 12" x 7 1/2"



Road Side Stand - Nostalgia Antique Shop
 30-90096 \$39.95
 Unit Measures: 8 1/2" x 5 7/16" x 4 1/4"

INTERIOR LIGHTING



Concession Stand - Sunrise Lemonade
 30-90056 \$39.95
 Unit Measures: 10 7/8" x 4 1/2" x 7 5/8"



Road Side Stand - Salt Water Taffy Candy Shop
 30-90097 \$39.95
 Unit Measures: 8 1/2" x 5 7/16" x 4 1/4"



Concession Stand - Steam Dawgs
 30-90055 \$39.95
 Unit Measures: 10 7/8" x 4 1/2" x 7 5/8"



Road Side Stand - Fireworks
 30-9093 \$39.95
 Unit Measures: 8 1/2" x 5 7/16" x 4 1/4"

Original McDonalds
 30-9034 \$59.95
 Unit Measures: 12" x 14 1/2" x 7 1/2"



Corner Building - Lenny's Bagel Shop
 30-90069 \$39.95
 Unit Measures: 9 7/8" x 7 7/16" x 7 1/16"



Corner Building - Super Stars Camera Shop
 30-90070 \$39.95
 Unit Measures: 9 7/8" x 7 7/16" x 7 1/16"



Opposite Corner Building w/Blinking Sign - Joe's Jumping Java Coffee Shop
 30-90061 \$49.95
 Unit Measures: 9 7/8" x 7 7/16" x 7 1/16"



Corner Building w/Blinking Sign - Cross Sticks Pool Hall
 30-90080 \$49.95
 Unit Measures: 9 7/8" x 7 7/16" x 7 1/16"



Opposite Corner Building w/Blinking Sign - Jed's Bicycle Shop
 30-90092 \$49.95
 Unit Measures: 9 7/8" x 7 7/16" x 7 1/16"

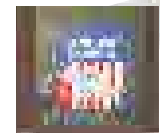

Opposite Corner Building w/Blinking Sign - Union Pacific Ticket Office
 30-90062 \$49.95
 Unit Measures: 9 7/8" x 7 7/16" x 7 1/16"



Opposite Corner Building w/Blinking Sign - Christmas Store
 30-90093 \$49.95
 Unit Measures: 9 7/8" x 7 7/16" x 7 1/16"



3-Story City Building - Lombardi's Pizza
 30-90019 \$39.95
 Unit Measures: 6 5/8" x 9 1/2" x 8 3/4"

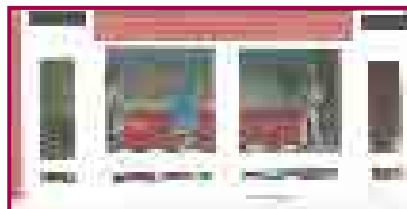

3-Story City Building w/Fire Escape & Blinking Sign -
 O'Mara's Irish Brewing Company
 30-90052 \$59.95
 Unit Measures: 12 3/4" x 6 5/16" x 9 3/16"



3-Story City Building - Katz's Deli
 30-90020 \$39.95
 Unit Measures: 6 5/8" x 9 1/2" x 8 3/4"



3-Story City Building w/Blinking Sign - Girardini's Italian Restaurant
 30-90050 \$59.95
 Unit Measures: 12 3/4" x 6 5/16" x 9 3/16"

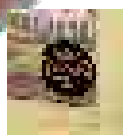

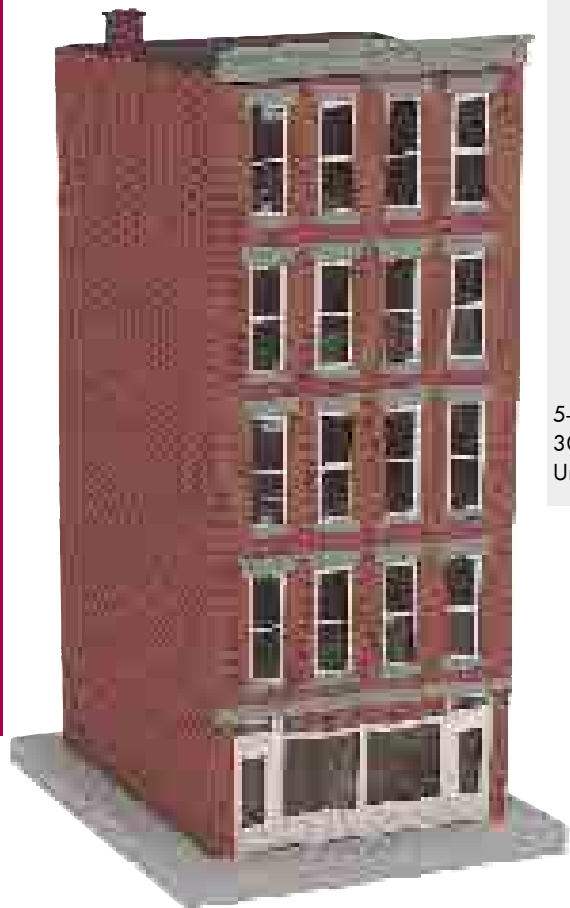

5-Story City Building - McHales Tavern
 30-90034 \$59.95
 Unit Measures: 6 1/2" x 9 1/2" x 13 1/2"



5-Story City Building - Forbes Tower
 30-90035 \$59.95
 Unit Measures: 6 1/2" x 9 1/2" x 13 1/2"



5-Story Flower Shop w/Blinking Sign
 30-90122 \$69.95
 Unit Measures: 12 3/4" X 6 5/16" X 9"



3-Story Pet Store w/Blinking Sign
 30-90121 \$49.95
 Unit Measures: 12 3/4" X 6 5/16" X 9"

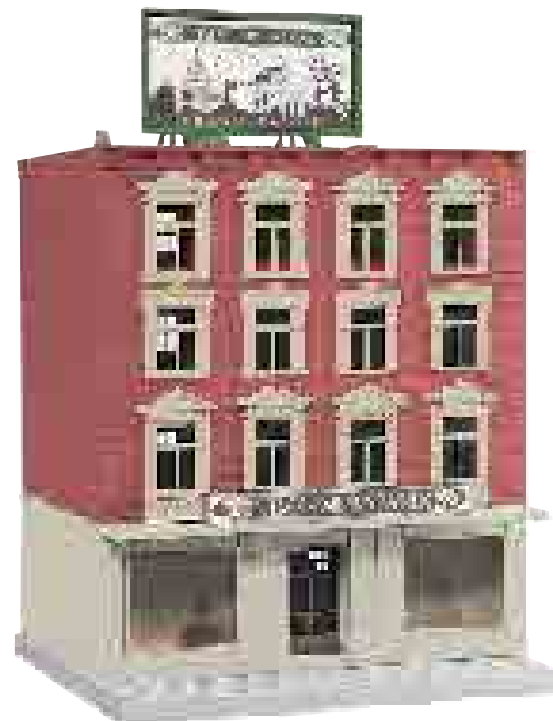

4-Story Building - Times Newspaper
 30-90078 \$49.95
 Unit Measures: 10 7/8" x 8 5/8" x 8 7/8"



6-Story Department Store - Schultzer Brothers
30-90124 \$79.95
Unit Measures: 9 3/8" x 9 3/8" x 15 7/8"



6-Story Building - The Brunswick
30-90016 \$59.95
Unit Measures: 8 7/8" x 8 5/8" x 15 5/8"



5-Story Hotel w/Blinking Sign - Normandy Hotel
30-90125 \$69.95
Unit Measures: 12 3/4" X 6 5/16" X 13 1/2"



6-Story Department Store - A.E. Mallard & Sons
30-90123 \$79.95
Unit Measures: 9 3/8" x 9 3/8" x 15 7/8"



6-Story Building - The Dreyfuss
30-9077 \$59.95
Unit Measures: 8 7/8" x 8 5/8" x 15 5/8"



Operating Storage Tank - Shell
30-9140 \$179.95
Unit Measures: 17 5/16" x 11" x 10"



Tank Filling Station - Shell
30-90039 \$49.95
Unit Measures: 16 1/8" x 5" x 8 1/8"



Operating Storage Tank Station - Shell
30-9141 \$179.95
Unit Measures: 16 1/8" x 5" x 8 1/8"

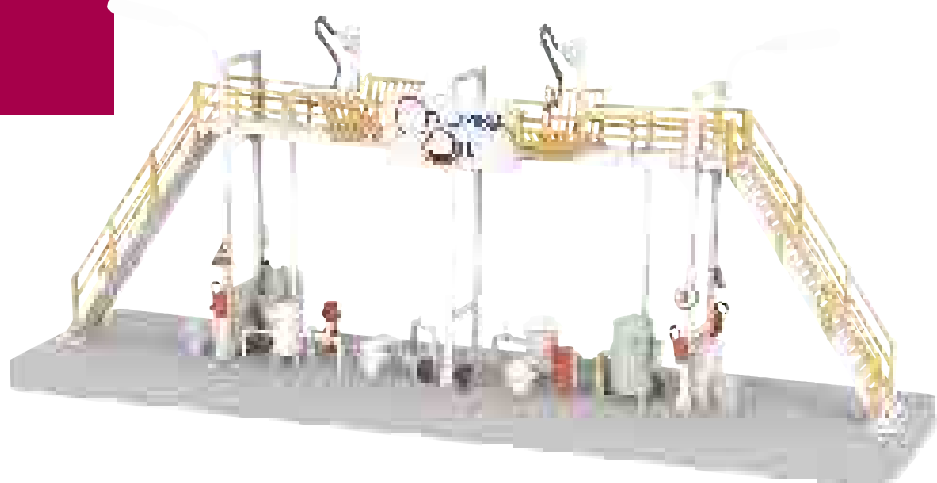

Tank Filling Station - Columbia Oil
30-90099 \$49.95
Unit Measures: 16 1/8" x 5" x 8 1/8"

Operating Transfer Dock
30-9110 \$179.95
Unit Measures: 20" x 9" x 9 1/2"

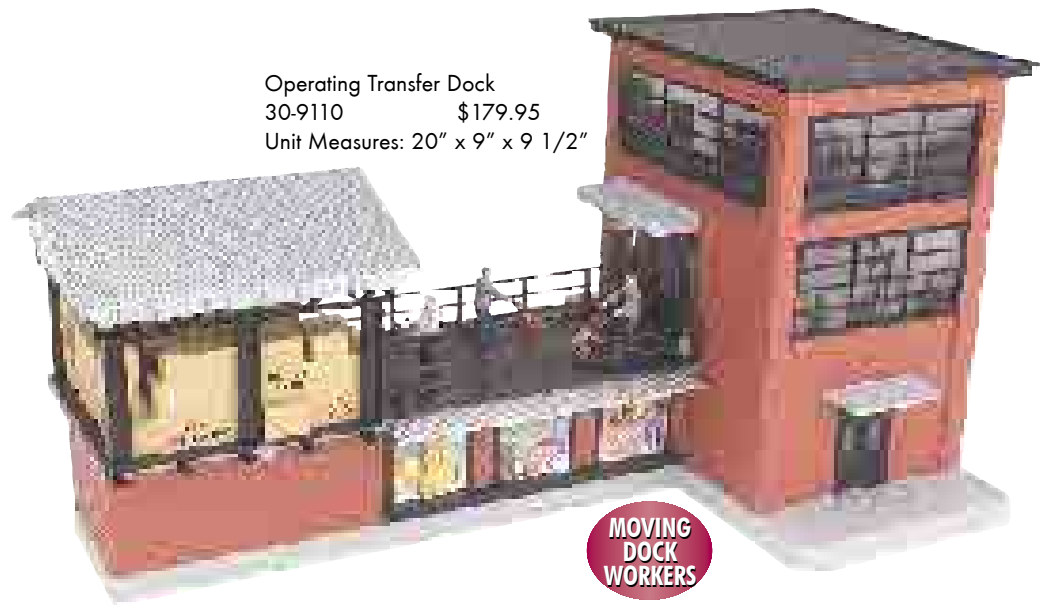

MOVING
DOCK
WORKERS

RailTown Signature Series

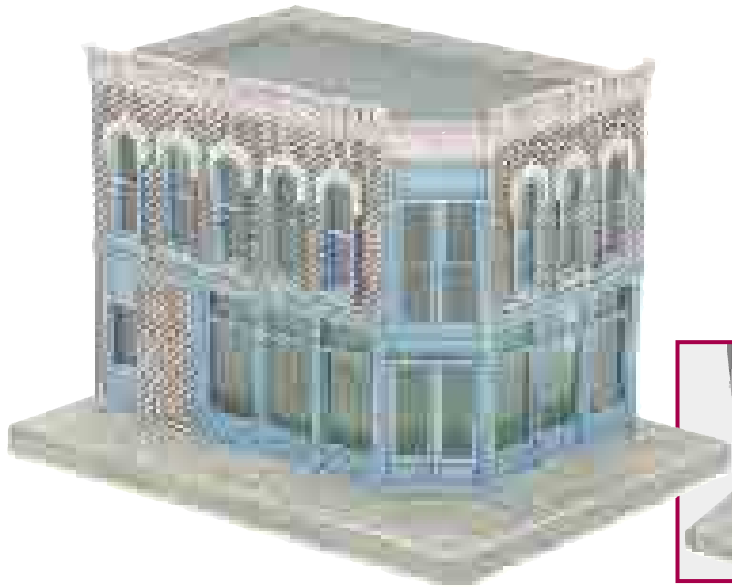

Weathered Opposite Corner Building w/Blinking - Christmas Store
30-90104 \$74.95
Unit Measures: 9 7/8" x 7 7/16" x 7"

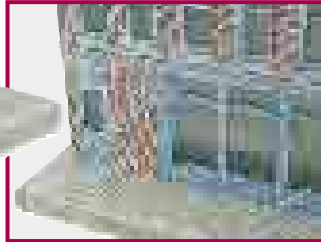

Weathered Public Works Building - Gray & White
30-90105 \$99.95
Unit Measures: 14 1/8 x 9 7/8 x 8 1/8



Weathered Country Passenger Station
30-90103 \$79.95
Unit Measures: 18 5/8" x 7 3/8" x 6 5/8"



Weathered Operating Storage Tank - Shell
30-9149 \$199.95
Unit Measures: 17 5/16" x 11" x 10"



Weathered Operating Storage Tank Station - Shell
30-9150 \$199.95
Unit Measures: 16 1/8" x 5" x 8 1/8"

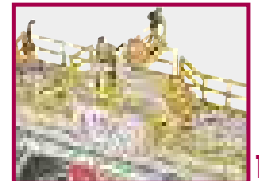



■ #334 Operating Dispatch Board
30-9022 \$99.95
Unit Measures: 10 1/2" x 4 1/4" x 7 1/2"

■ Milk Platform - Green
30-9063 \$49.95
Unit Measures: 7 1/8" x 5 7/8" x 2 1/2"



**METAL
CONSTRUCTION**



■ Operating Radar Tower
30-9032 \$39.95
Unit Measures: 4 1/2" x 5" x 11 1/2"

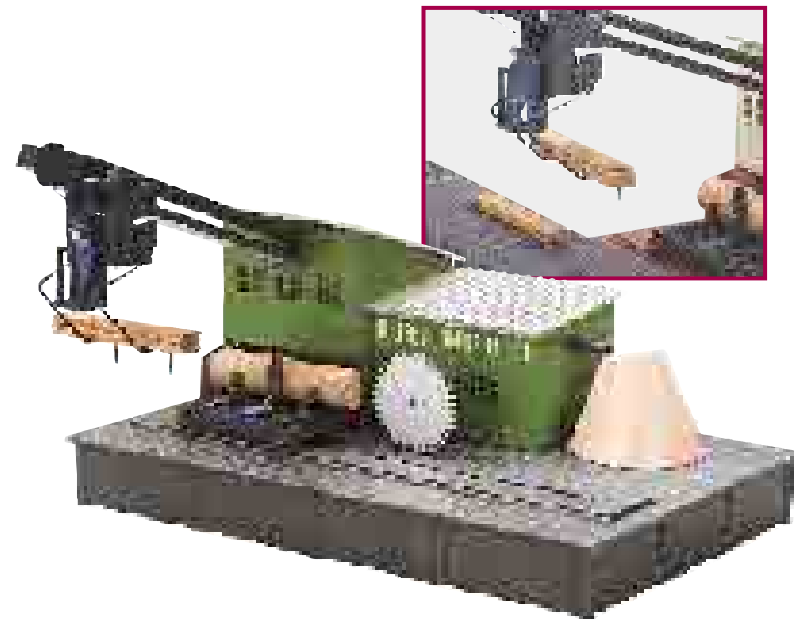

■ No. 23796 Operating Saw Mill - Hill Crest Lumber
30-9143 \$89.95
Unit Measures: 10 1/2" x 9 1/2" x 6 1/2"



■ No. 23796 Operating Saw Mill - Western Maryland
30-9144 \$89.95
Unit Measures: 10 1/2" x 9 1/2" x 6 1/2"



■ 314 Die-Cast Girder Bridge - Pennsylvania
30-12001 \$19.95
Unit Measures: 10" x 4 1/2" x 1 3/4"



■ 314 Die-Cast Girder Bridge - New York Central
30-12003 \$19.95
Unit Measures: 10" x 4 1/2" x 1 3/4"

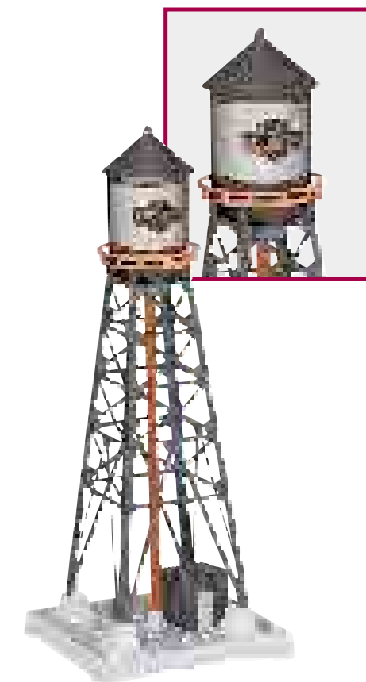

■ #193 Industrial Water Tower w/ Flashing Light - Harley-Davidson®
30-90110 \$49.95
Unit Measures: 6" x 6" x 14 3/4"

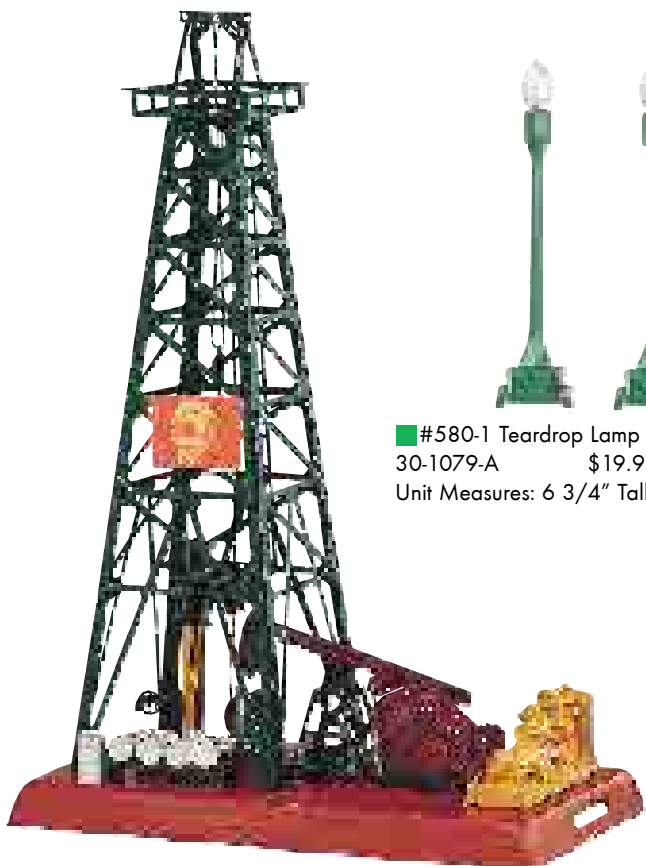

■ #455 Oil Derrick - Shell
30-90033 \$89.95
Unit Measures: 9 3/4" x 5 3/4" x 13 3/4"



■ #580-1 Teardrop Lamp Set - Pea Green
30-1079-A \$19.95
Unit Measures: 6 3/4" Tall



■ #151 Operating Semaphore - Green Base
30-1075 \$29.95
Unit Measures: 9 5/8" Tall



Harley-Davidson® Goods, Registered Trademark of H-D Michigan, Inc.
© H-D®. All Rights Reserved.



■ #153 Operating Block Signal - Black
30-1076 \$29.95
Unit Measures: 9 1/8" Tall



■ Operating Banjo Signal
30-1093 \$29.95
Unit Measures: 9 1/8" Tall

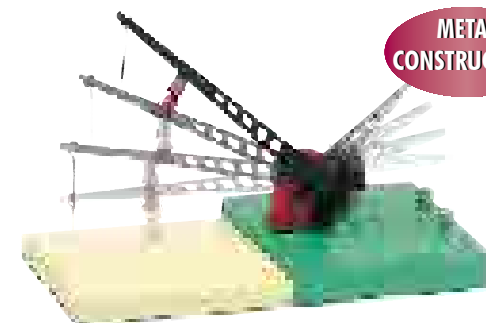

METAL CONSTRUCTION

■ #46 Crossing Gate and Signal
30-11017 \$59.95
Unit Measures: 16 1/2" x 3 1/2" x 5 3/4"

JOIN THE CLUB

GET THE MOST FROM MODEL RAILROADING

There are FOUR different types of memberships, based on the style of model railroading that most interests you.



MTHRC - Rounded Roof Box with Generator

RAILKING MEMBERSHIP \$50.00 PREMIER MEMBERSHIP \$50.00



MTHRC - Santa Fe - 50' HighCube Box Car

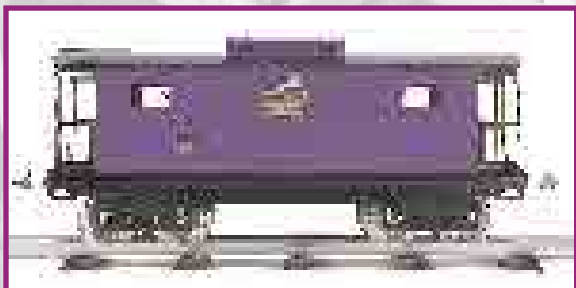

MTHRC - 200 Series Std. Gauge Caboose

TINPLATE MEMBERSHIP \$120.00 ONE GAUGE MEMBERSHIP \$100.00



MTHRC - Hooker - Unibody Tank Car



CELEBRATE M.T.H.'S 25TH ANNIVERSARY

CHROME PLATED

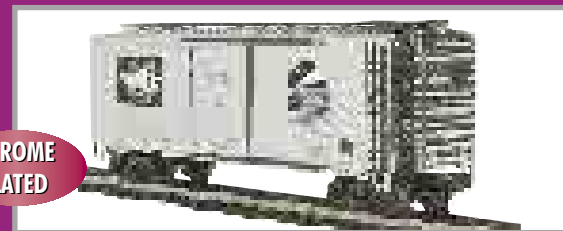

Premier MTH 25th Anniversary - Box Car
Unit Measures: 11 5/8" x 2 5/8" x 3 3/4" • O-31 Curves
20-93248 \$59.95

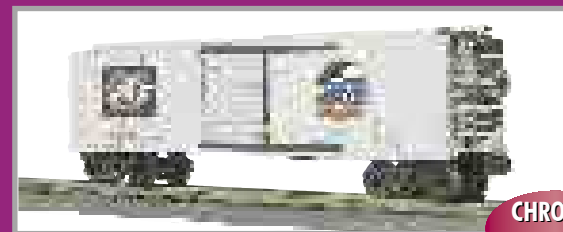

CHROME PLATED

RailKing MTH 25th Anniversary - Box Car
Unit Measures: 11 1/2" x 2 3/8" x 2 5/16" • O-27 Curves
30-74219 \$49.95

CHROME PLATED

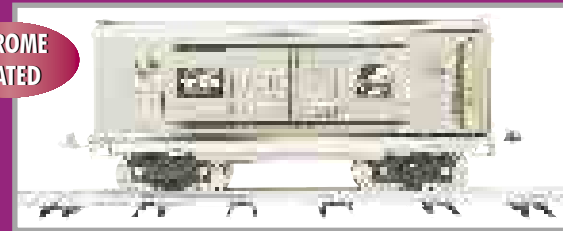

TinPlate MTH 25th Anniversary - 200 Series Std. Gauge Box Car
Unit Measures: 14" x 4" x 5 1/4" • STD-42 Curves
10-2111 \$129.95

CLUB MEMBERS ORDER ONLINE AND SAVE 10%!

GET THE INSIDE SCOOP!

AS A MEMBER OF THE M.T.H. RAILROADERS CLUB® YOU'LL RECEIVE:

Limited-Edition Club Car

Each year we produce beautifully decorated cars exclusively for our Club members. Members automatically receive the car that matches their Club membership (RailKing®, Premier, Tinplate Traditions® or One Gauge) & have the option to collect the other Club cars as well.

The CrossingGate®, Club Magazine

You will receive our full color Club magazines, jam-packed with product news, layout tours, ideas from other members, rail history, & step-by-step articles explaining how M.T.H. technology can bring your railroad to life.

1st Class Mailing of M.T.H. Catalogs

Club members get the catalogs, filled with cool, limited-run engines & accessories, earlier than the rest of our mailing list, so they can order from their local train store before the best items are sold out.

Club Web Site

Visit www.mthtrains.com & type in your member number to gain access to the Club web site. Here you can exchange messages with other Club members, keep up with the latest news, & even build your own homepage.

RailWare™ Software CD-ROM

Use your computer to design track layouts, search the database of all M.T.H. products, look at our past catalogs, listen to Proto-Sound®2.0 train effects, & much more. This CD retails for \$79.95, but is yours FREE as a Club member.

Club Card & Lapel Pin

Show the world your membership in this elite group of model railroaders with your high-quality embossed membership card & beautiful enamel lapel pin.

Proto-Sound® 2.0 Upgrade Kits

Club members can save an additional 15% on these kits by visiting the MTHRC web page.

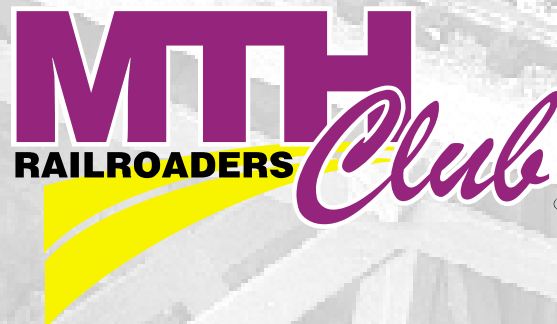

Carry on the M.T.H. tradition with memorabilia and collectibles

MTH Promotional DVD

This video is packed full of sights & sounds guaranteed to make you rethink how far the hobby of model railroading has come. You'll learn about some of the most innovative products ever produced & marvel at the sophistication of a product line unmatched by other model train manufacturers.

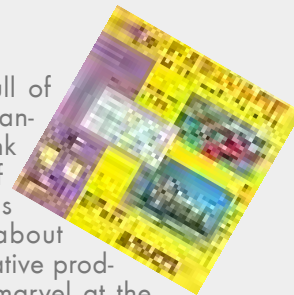

Previous Year Club Cars

MTHRC members can still obtain earlier produced MTHRC cars by visiting the MTHRC pages on the website. Only MTHRC members can get these cars!



A Toy Train Story

This comprehensive book is a must for collectors & other lovers of toy trains. 350 pages & 1900 color photos, hard cover. Add this book to your membership for only \$25.00 (50% off the \$49.95 cover price)!

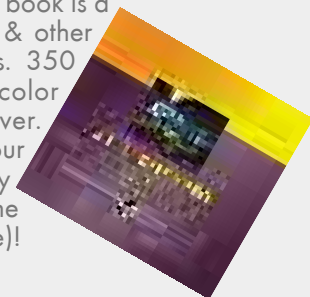



On-line & toll free access to the network of M.T.H. Authorized Retailers & "tools" on the M.T.H. website (www.mthtrains.com), such as the M.T.H. Product Locator, have helped many train enthusiasts locate nearby retailers, service centers or even a particular desired product for years.

Now, M.T.H.'s new on-line "Dealer Availability" finder allows customers interested in a newly-announced product to find a retailer with the item(s) on order.

In addition, M.T.H. is expanding these services with two ALL NEW programs that will provide consumers with access to retailers who provide a superior environment for showcasing & demonstrating M.T.H. products & cutting edge technology.

At M.T.H. Authorized DCS™ Demo Centers, you can now expect to see DCS™ & Proto-Sound® 2.0 equipped locomotives in action, find DCS™ in stock & learn more about this exciting command control system from experienced DCS™ staff members.

M.T.H. Authorized Mega Station Retailers are your best bet for finding the widest selection of M.T.H. products in stock when you want them. Like a DCS™ Demo Center, your local Mega Station retailer has DCS™ in stock & the know-how to get you up & running in no time.

Not all products depicted in this catalog are production models. In some cases, the items pictured may be HO, O Scale or some other scale product. All item's graphic features and content are subject to change after publication. All product features may be verified on their retail packages.

©2004, M.T.H. Electric Trains, 7020 Columbia Gateway Drive, Columbia Maryland 21046-1532 o www.mthtrains.com o 410/381-2580

MTH Trademarks: M.T.H. Electric Trains®, M.T.H.®, MTH Railroaders Club®, Ives®, Loco-Sound®, Proto-Sound® 2.0, Proto-Speed Control™, Proto-Doppler™, Proto-Dispatch™, Proto-Cast™, Proto-Smoke™, Proto-Coupler™, Proto-Effects™, RailKings®, Rugged Rails®, RailTown™, Tinplate Traditions®, ScaleTrax™, RealTrax®, Z-500®, Z-750®, Z-4000®, Z-1000™, Z-4000® Remote Commander™, DCS™ and the MTH Numbering System and all others indicated throughout this catalog. Lionel and Trainmaster are registered trademarks of Lionel L.L.C., Ertl is a registered trademark of Ertl Collectibles, McDonald's® is a registered trademark of the McDonald's Corporation, CAT, Caterpillar, and their design marks are registered trademarks of Caterpillar Inc., John Deere is a registered trademark of Deere & Company, RealTrax® layouts created with RR-Track™ which is a registered trademark of R&S Enterprises, Greyhound® is a registered trademark of the Greyhound Lines Inc., NJ Transit is a registered trademark of NJ Transit, Inc., Jeep® is a registered trademark of DaimlerChrysler.

Nickelodeon, SpongeBob SquarePants and all related titles, logos and characters are trademarks of Viacom International Inc. Created by Stephen Hillenburg

Harley-Davidson® Goods, Registered Trademark of HD Michigan, Inc. © H-D®. All Rights Reserved.

Major League Baseball trademarks and copyrights are used with permission of Major League Baseball Properties, Inc. MLB.com MTH Trains/MLBP 2004

Popsicle, Klondike, Good Humor are registered trademarks of Good Humor-Breyers

M.T.H.'s DCS Digital Command System has received U.S. Patent No. 6,457,681. M.T.H.'s Proto-Sound 2.0 system has received U.S. Patent No's 6,457,681 B1 (sound system), 6,457,681 B1 (Proto-Speed Control), 6,604,641 (Proto-Coupler), 6,280,278 (Proto-Smoke).

M.T.H.'s RealTrax has received U.S. Patent No. 6,019,289.

M.T.H.'s ScaleTrax switches have received U.S. Patent No. 6,491,263.

M.T.H.'s Z-4000 Transformer has received U.S. Patent No's. 6,281,606 & 6,624,537.

M.T.H.'s Proto-Scale 3-2 has received U.S. Patent No. 6,662,917

Some images used in this publication © 2004 www.clipart.com

M T H O G A U G E M E G A S T A T I O N S

Florida

READY TO ROLL
831 NW 143 ST.
MIAMI, FL 33168
Phone: 305-688-8868
Email: rtrtrains@aol.com

ROUNDHOUSE SOUTH
4611 S RIDGEWOOD AVE
PORT ORANGE, FL 32127
Phone: 386-304-7002
Email: info@roundhousesouth.com

Illinois

BERWYNS TOY TRAINS & MODELS
7025 OGDEN AVENUE
RT. 66
BERWYN, IL 60402
Phone: 708-484-4384
Email: berwynstoytrains@comcast.net

CHICAGOLAND HOBBY
6017 NORTHWEST HWY.
CHICAGO, IL 60631
Phone: 773-775-4848
Email: chicagolandhobby@sbcglobal.net

Massachusetts

NORTHEAST TRAINS
18 MAIN STREET
PEABODY, MA 01960
Phone: 978-532-1615
Email: netrains@netrains.com

Maryland

CATOCTIN MTN. TRAINS & HOBBIES
#3 WEST MAIN STREET
THURMONT, MD 21788
Phone: 301-694-8331
Email: trainspj@aol.com

ENGINE HOUSE HOBBIES
315-G EAST DIAMOND AVENUE
GAITHERSBURG, MD 20877
Phone: 301-590-0816
Email: luciecerise@aol.com

SIDETRACK HOBBIES
PO BOX 1707
25470 POINT LOOKOUT ROAD
LEONARDTOWN, MD 20650
Phone: 301-475-5800
Email: arudman@erols.com

New Hampshire

MOUNTAIN TRAINS
25 LOWELL STREET
MANCHESTER, NH 03101
Phone: 603-641-1113
Email: orders@mountaintrains.com

New Jersey

THE HOBBY SHOP
1077C HIGHWAY 34
ABERDEEN TOWNSQUARE SHP CNT
ABERDEEN, NJ 07747
Phone: 732-583-0505
Email: sales@hobbyshopnj.com

TRAINS & THINGS
242 SCOTCH ROAD
GLEN-ROC SHOPPING CENTER
TRENTON, NJ 08628
Phone: 609-883-8790
Email: trainsanthings@aol.com

New York

TRAIN WORLD
751 MCDONALD AVE.
BROOKLYN, NY 11218
Phone: 718-436-7072
Email: orders@trainworld.com

NASSAU HOBBY
13 W. MERRICK RD.
FREEPORT, NY 11520
Phone: 516-378-9594
Email: Charlienassau@aol.com

SCAGS ELECTRIC TRAIN SHOP
114 VICTORY BLVD
STATEN ISLAND, NY 10301
Phone: 718-727-7373
Email: patscags@msn.com

TRAIN LAND
293 SUNRISE HWY.
LYNBROOK LONG ISLAND, NY
11563
Phone: 516-599-7080
Email: trainlife@aol.com

Ohio

DIXIE UNION STATION
110 W. MAIN STREET
MASON, OH 45040
Phone: 513-459-0460
Email: rockylane@core.com

GLENS TRAIN SHOP
587 GRANT ST.
AKRON, OH 44311
Phone: 330-253-6527
Email: robert@glenstrainshop.com



MTH Electric Trains, 7020 Columbia Gateway Drive, Columbia, MD 21046

P - 410-381-2580 • F - 410-381-6122 • Toll-Free Dealer Locator - 1-888-640-3700

H O M E P A G E

FIND IT HERE

Service Information

Our Service Page is your direct link to the M.T.H. Tech Support Team. Register your warranty, find a local service center or submit a product specific question here. You can even place a parts order through our secured server. It's easy and quick like it should be when you're looking for answers.

Product Locator

The most popular section of the M.T.H. website can be found here. This is where visitors come looking to locate a particular product within the vast M.T.H. Authorized Retailer network. Developed in 1999, no other manufacturer has yet created a service like this for their customers. With over 8,000 items in the M.T.H. product line, this tool is your best bet for finding a hard-to-get M.T.H. item.

View a catalog

The latest products featured in each M.T.H. catalog can be seen here. This is a popular destination for customers waiting for a new catalog to arrive in the mail. Sign up for our free electronic newsletter & you'll be notified when a new catalog has been posted online. You'll have all the news and details before any of your friends.

Shipping Schedule

Keeping track of all those M.T.H. items would be an impossible task without our online shipping schedule. We update the schedule every week with the latest monthly releases. You can access this information directly or from the Product Locator section.

Free Electronic Newsletter

Upon sign-up you will receive electronic newsletters featuring information on new M.T.H. products, industry news plus sneak peaks at upcoming specials! It's the best way to stay abreast of the latest happenings at M.T.H. Electric Trains



A quick trip to the M.T.H. website will result in a wealth of information on M.T.H. products from a site that was designed to give the visitor easy access to all things M.T.H. Here you will find a complete list of M.T.H. products, an easy to use product / dealer locator, tons of news & information on M.T.H. You can even watch videos of M.T.H. products in action.

www.mthtrains.com

